

## aeiou

### Naming Capital and Lowercase Letters

**Directions:** Look at the letters. Circle all the capital letters.  
Then say each letter name aloud.

T	q	b	F	v
n	M	z	P	a
S	r	G	t	C
d	y	e	J	k
L	x	H	w	I

## aeiou

### Naming Capital and Lowercase Letters

**Directions:** Look at the letters. Circle all the capital letters. Then say each letter name aloud.

T	q	b	F	v
n	M	z	P	a
S	r	G	t	C
d	y	e	J	k
L	x	H	w	I



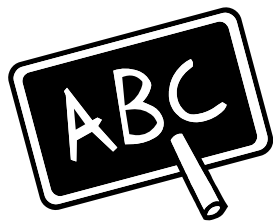

## Identifying Beginning Sounds

**Directions:** Look at the picture in each row. Say the name of each picture aloud. Then circle the picture that has the same beginning sound as the first picture.

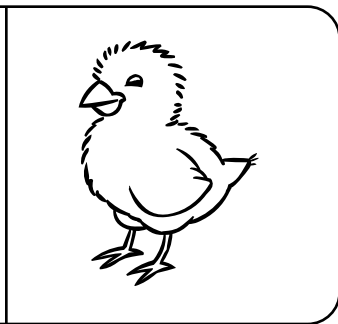
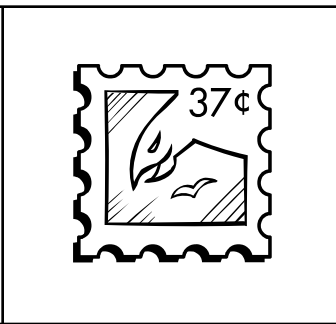
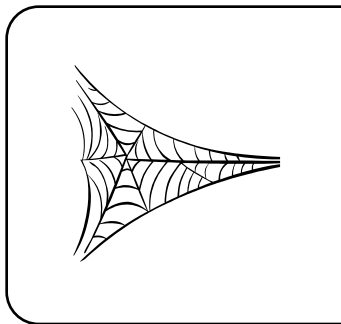
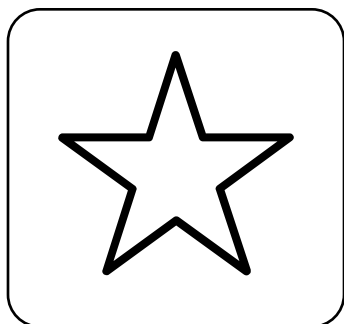
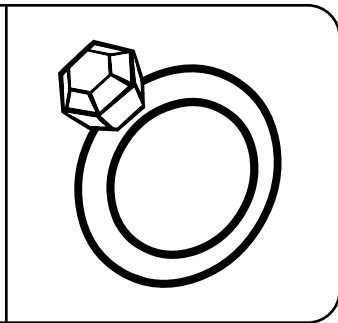
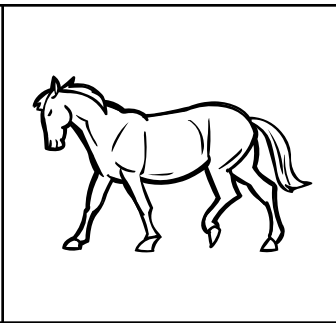
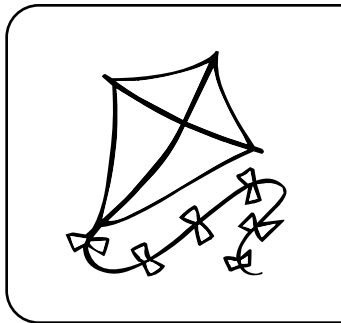
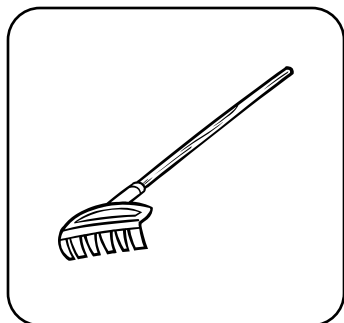
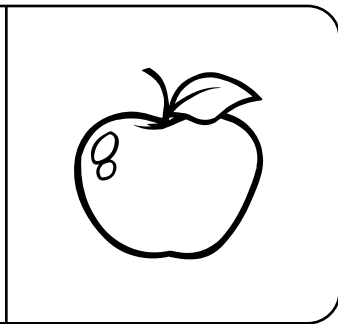
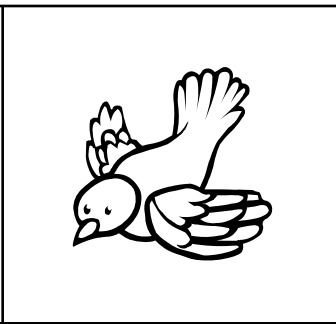
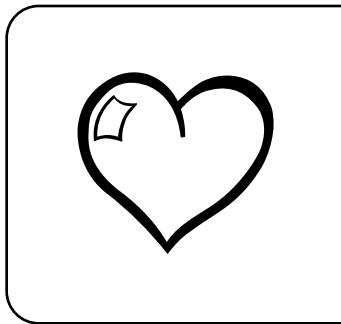
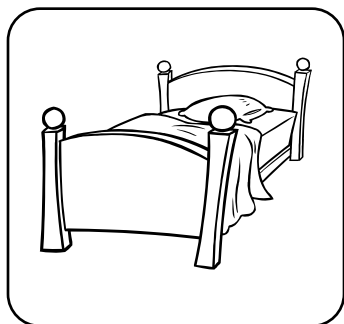
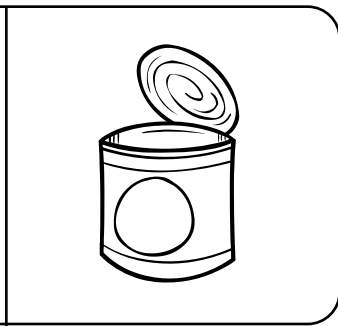
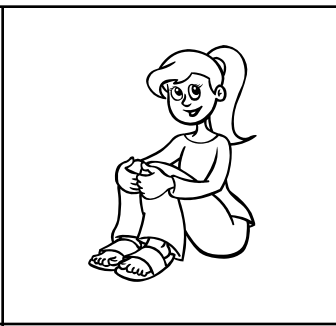
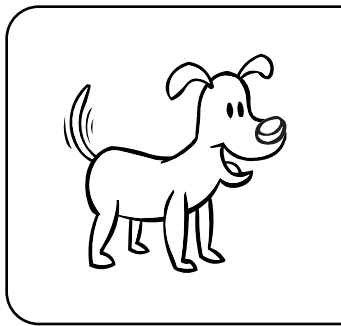
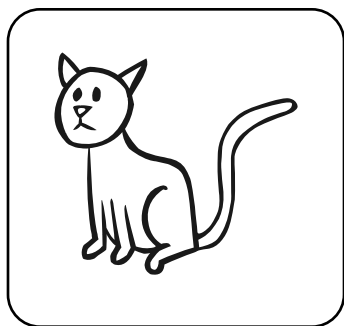

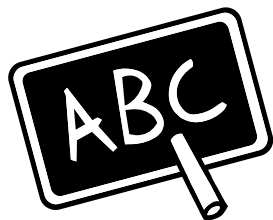

## Identifying Beginning Sounds

**Directions:** Look at the picture in each row. Say the name of each picture aloud. Then circle the picture that has the same beginning sound as the first picture.

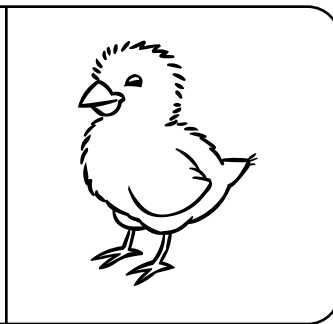
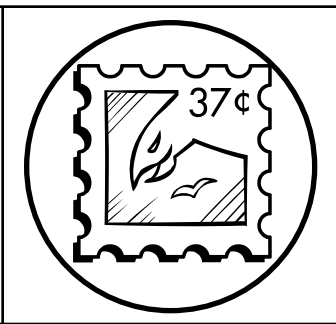
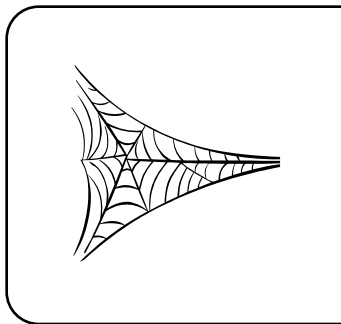
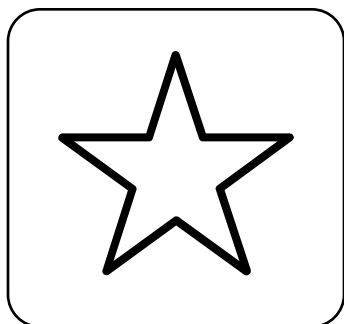
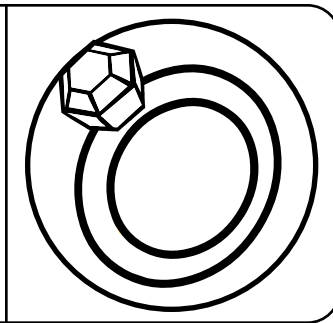
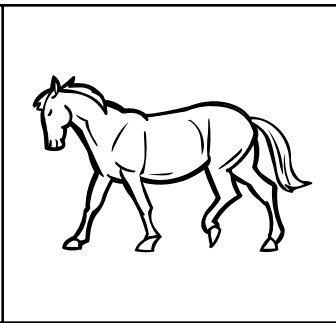
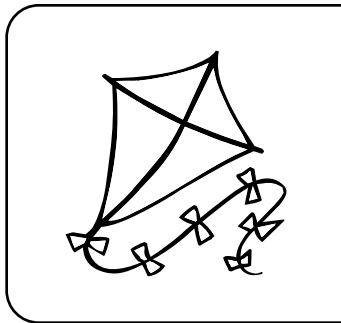
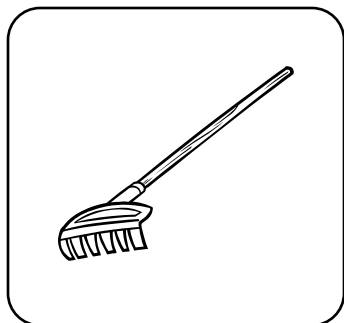
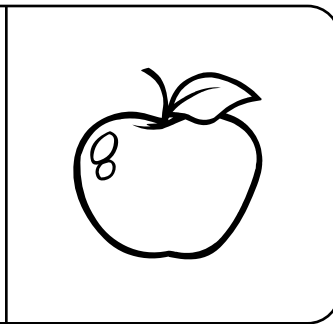
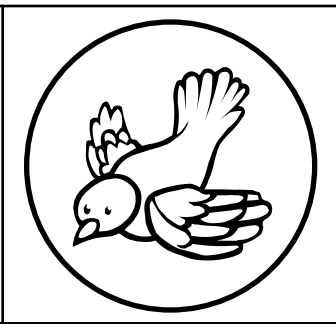
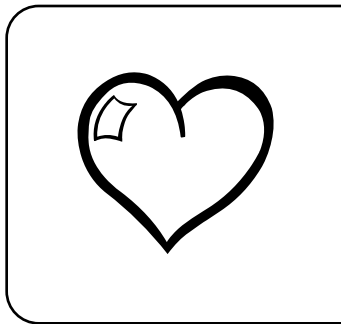
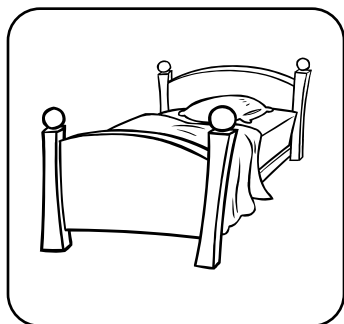
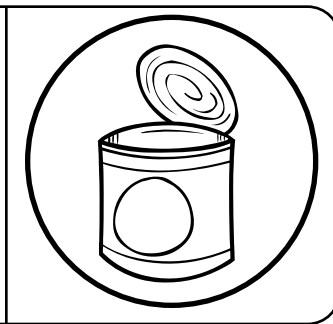
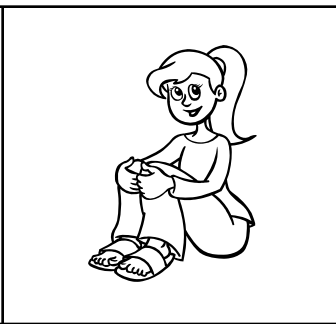
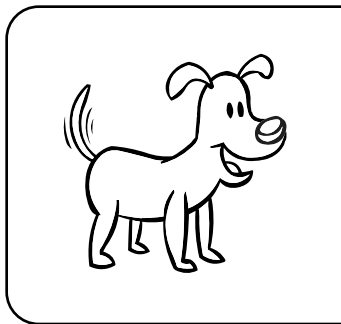
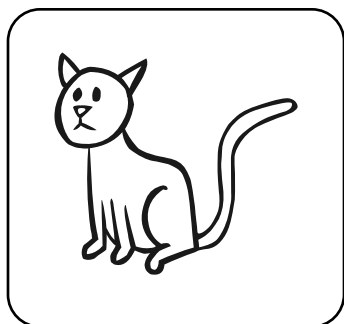

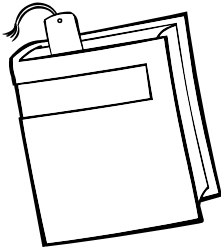

## Answering Questions about Main Characters

**Directions:** Cut out the pages and put them in order. Staple the pages together. Then read the story and answer the question.

### Mandy's New Home



by Barbara Davis-Pyles

Name \_\_\_\_\_

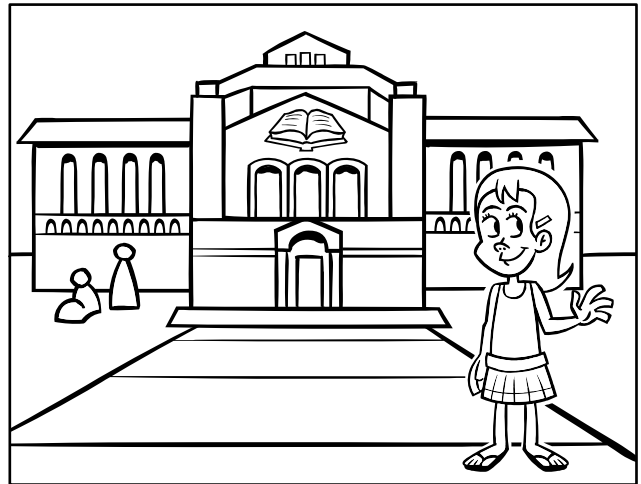

Mandy sees a library.

1

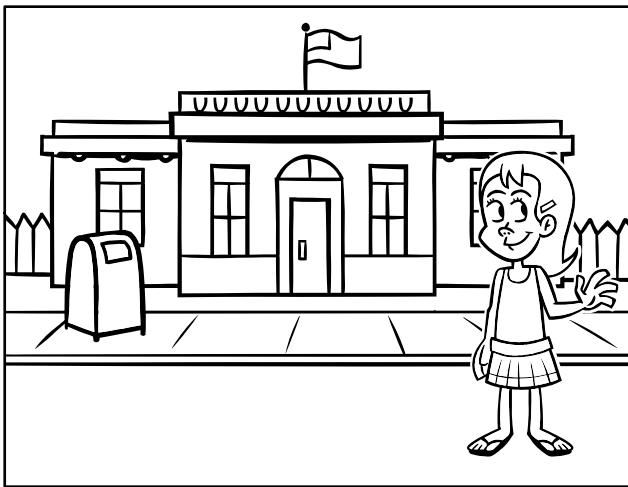

Mandy sees a post office.

2

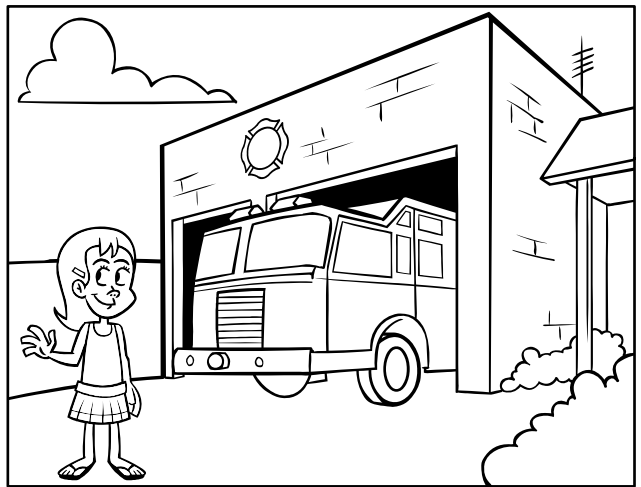

Mandy sees a fire station.

3

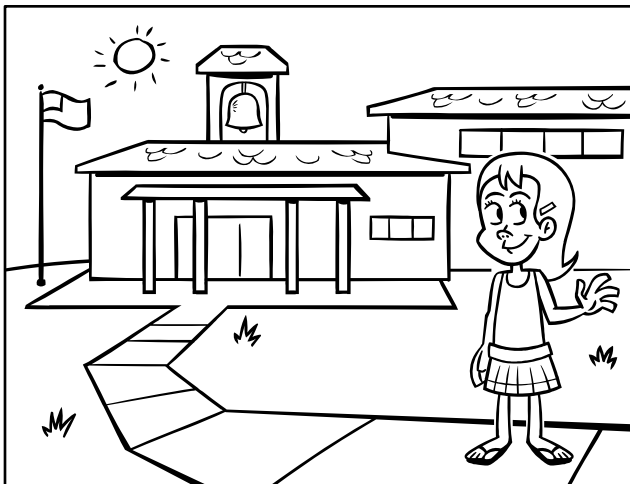

Mandy sees a school.

4

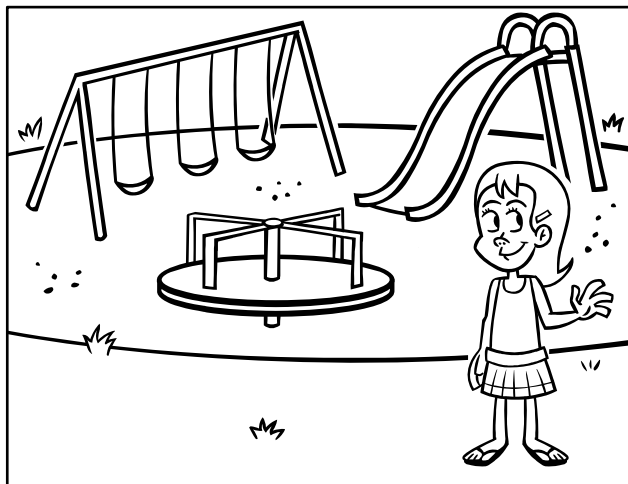

Mandy sees a playground.

5

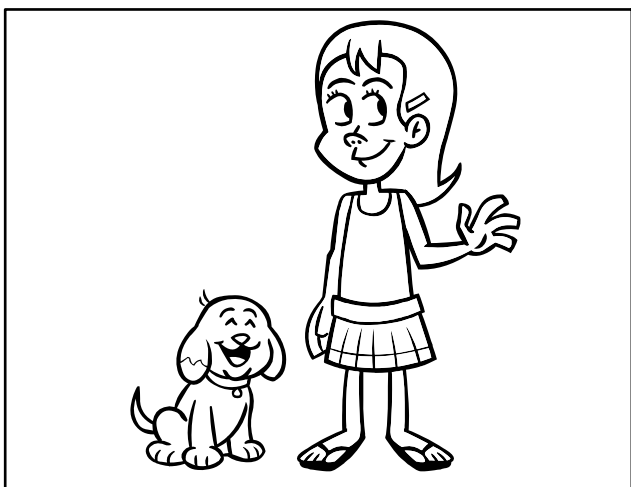

Mandy sees a puppy.

6

Who is the story about?

---

---

---

7

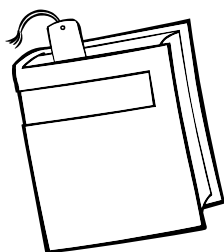

## Answering Questions about Main Characters

**Directions:** Cut out the pages and put them in order. Staple the pages together. Then read the story and answer the question.

### Mandy's New Home



by Barbara Davis-Pyles

Name \_\_\_\_\_

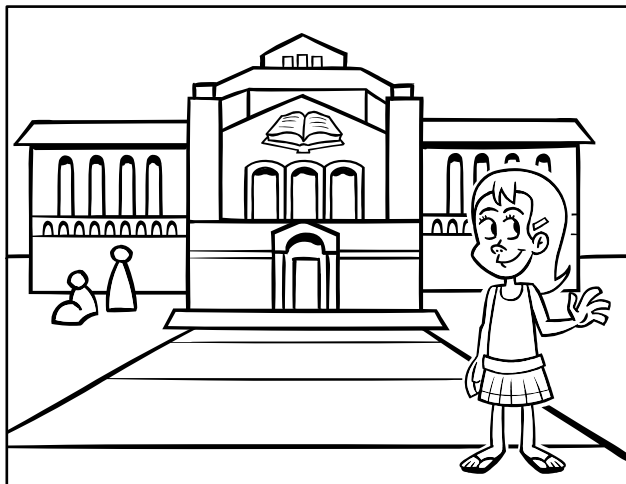

Mandy sees a library.

1

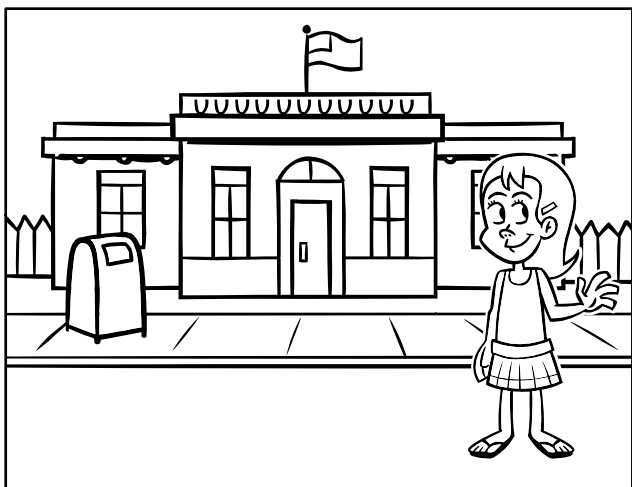

Mandy sees a post office.

2

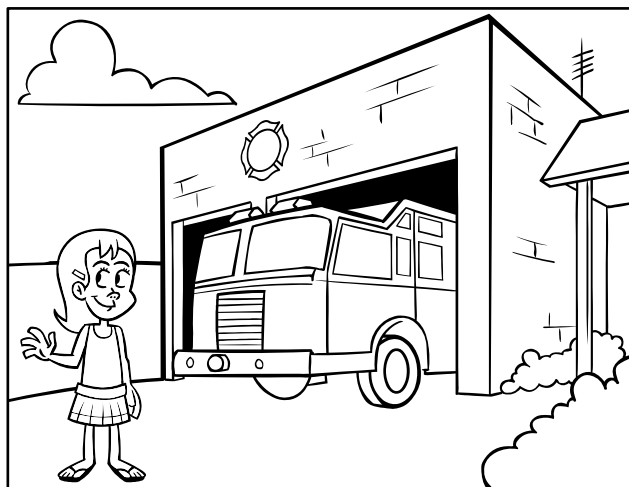

Mandy sees a fire station.

3

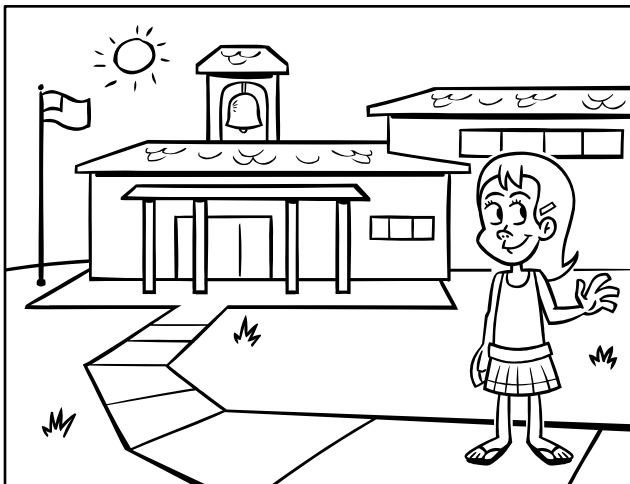

Mandy sees a school.

4

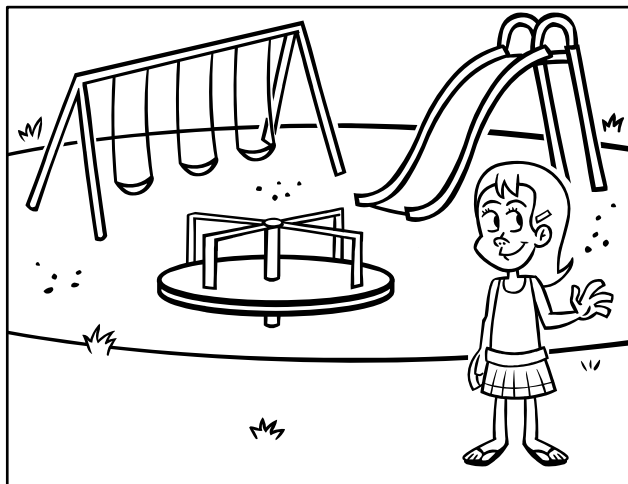

Mandy sees a playground.

5

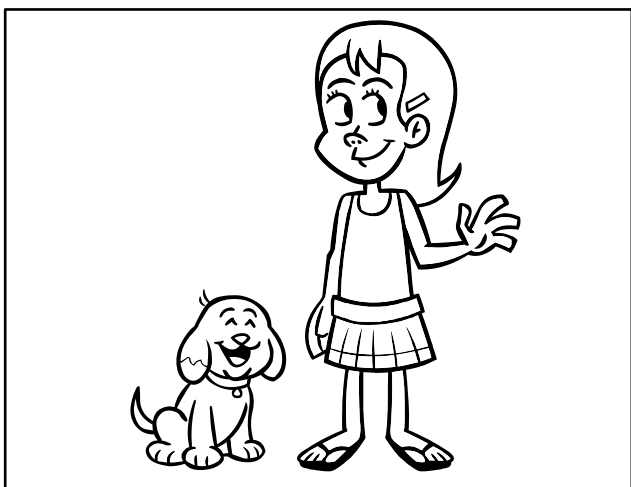

Mandy sees a puppy.

6

Who is the story about?

**Pictures  
will vary.**

\_\_\_\_\_

----- **Mandy** -----

\_\_\_\_\_

7



## Recognizing Rhyming Words

**Directions:** Look at the picture in each row. Say the name of each picture aloud. Then circle the picture that rhymes with the first picture.

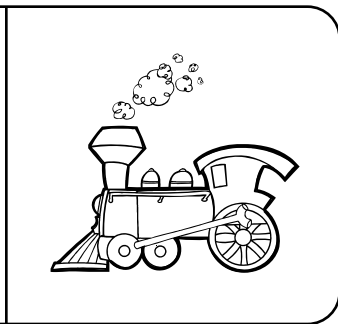
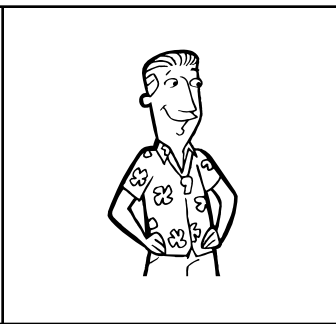
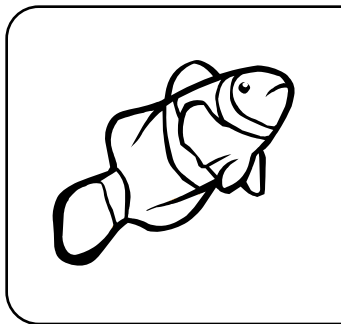
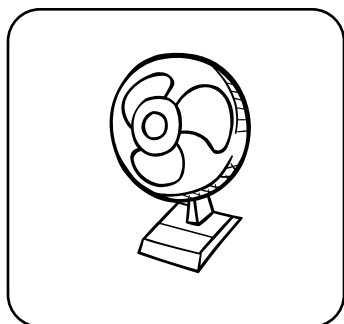
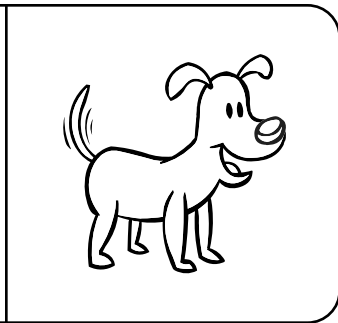
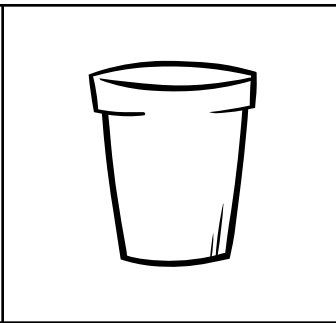
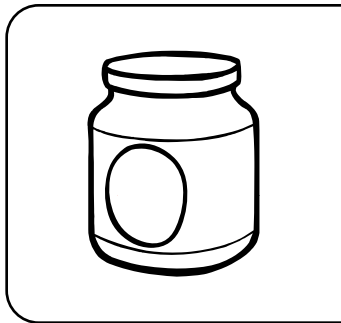
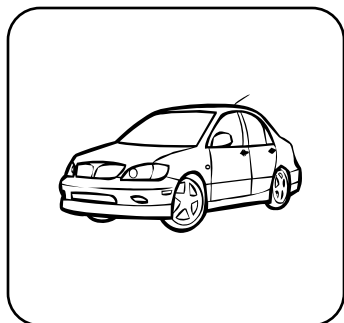
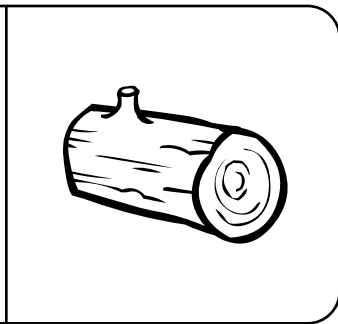
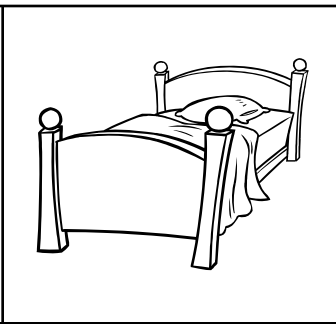
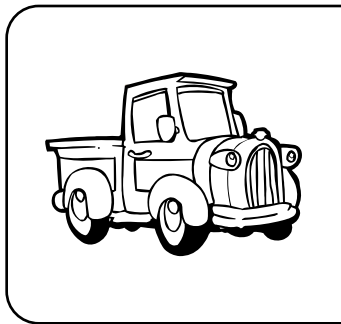
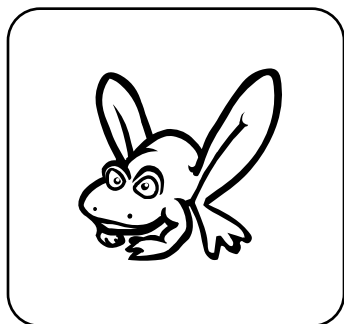
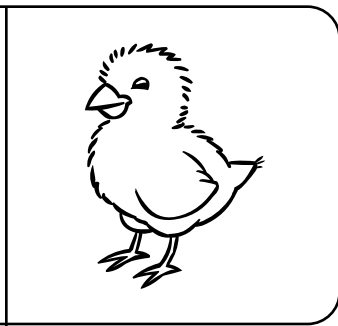
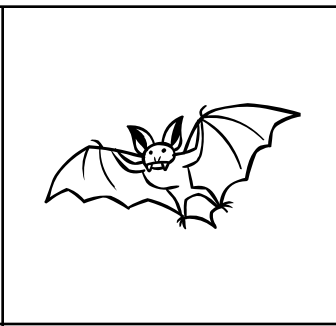
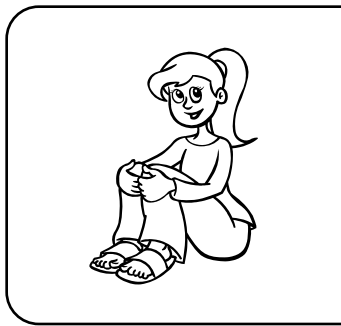
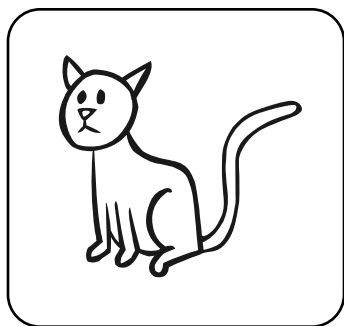



## Recognizing Rhyming Words

**Directions:** Look at the picture in each row. Say the name of each picture aloud. Then circle the picture that rhymes with the first picture.

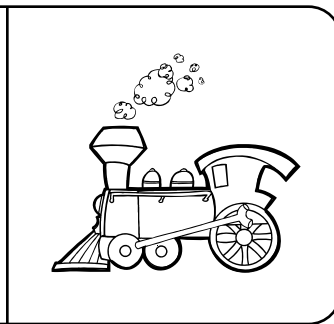
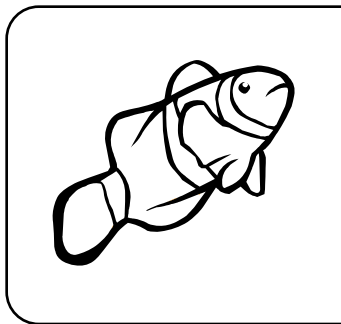
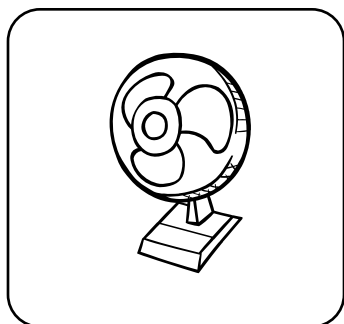
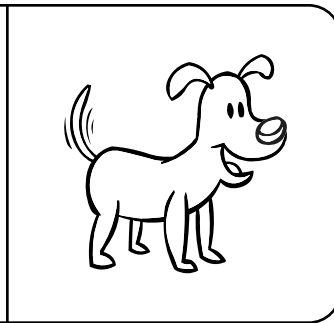
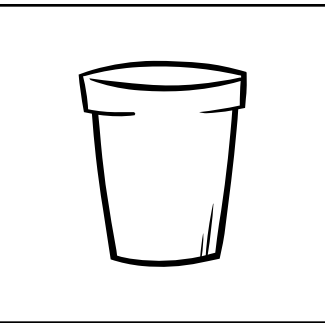
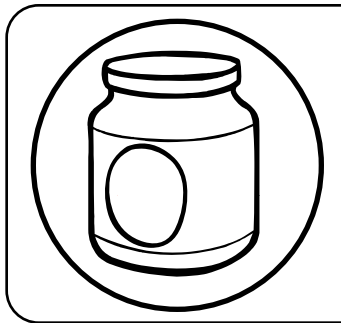
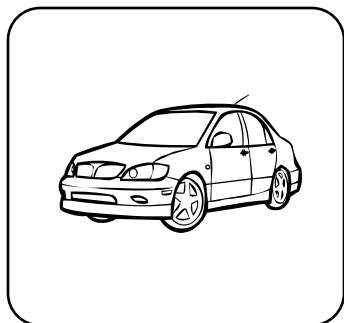
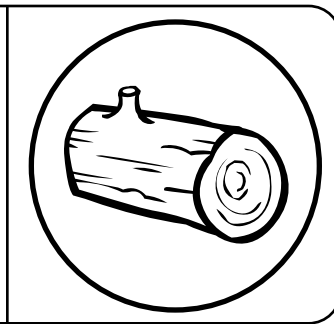
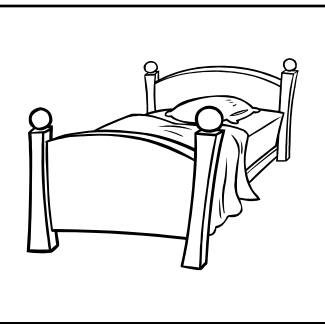
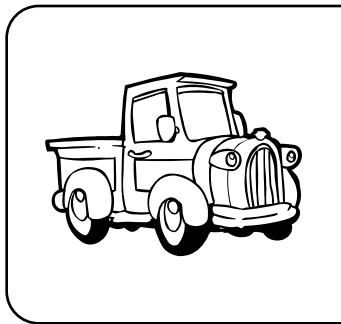
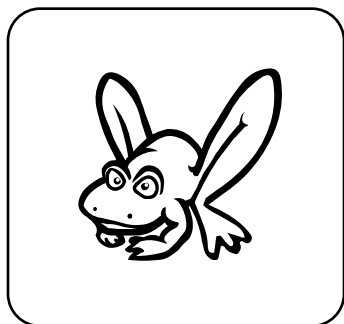
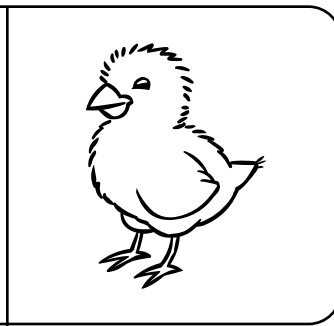
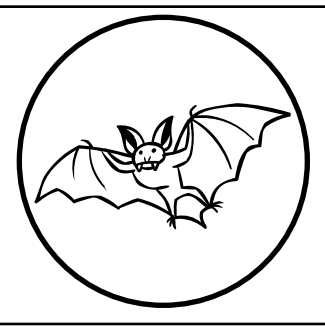
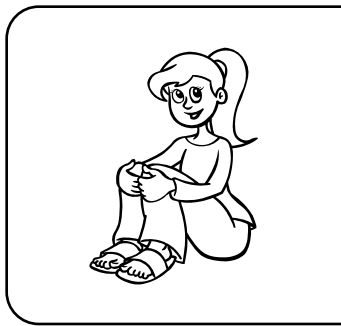
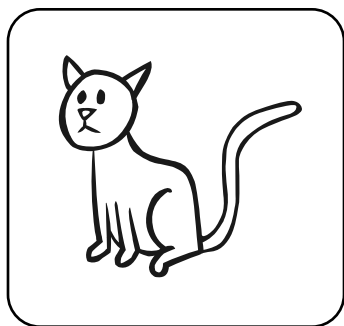



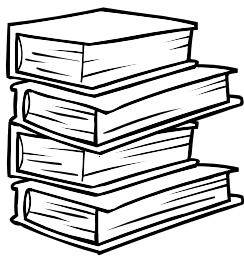

## Naming Capital Letters and Identifying Pictures with Same Beginning Sounds

**Directions:** Look at the letters. Circle all the capital letters. Then say each letter name aloud.

r	V	p	A	S
---	---	---	---	---

**Directions:** Say the name of each picture aloud. Then circle the picture that has the same beginning sound as the first picture.

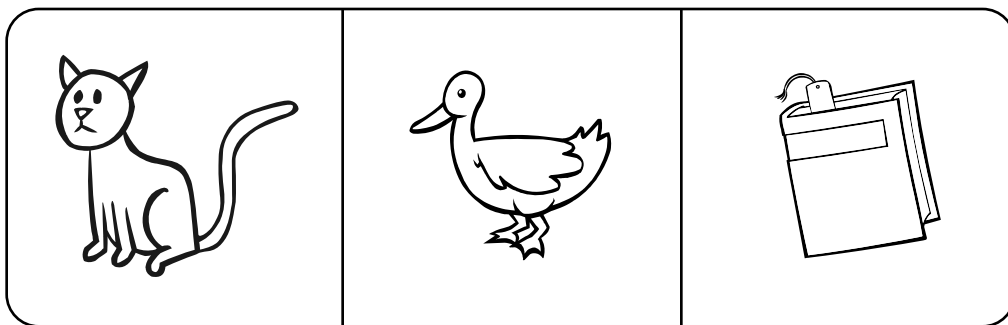
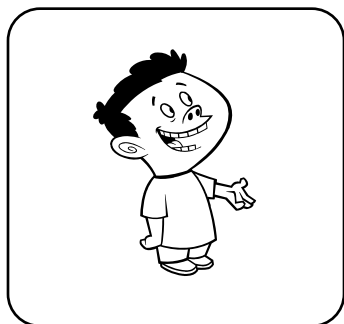

**Directions:** Say the name of each picture aloud. Then circle the picture that rhymes with the first picture.

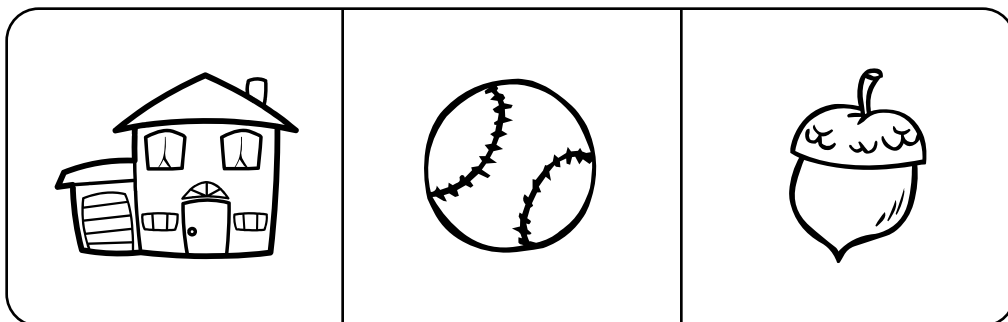

**Directions:** Cut out the pages and put them in order. Staple the pages together. Then read the story and answer the question.

## In My Family

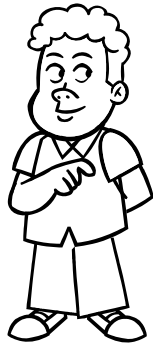

by Nicole Mead

Name \_\_\_\_\_

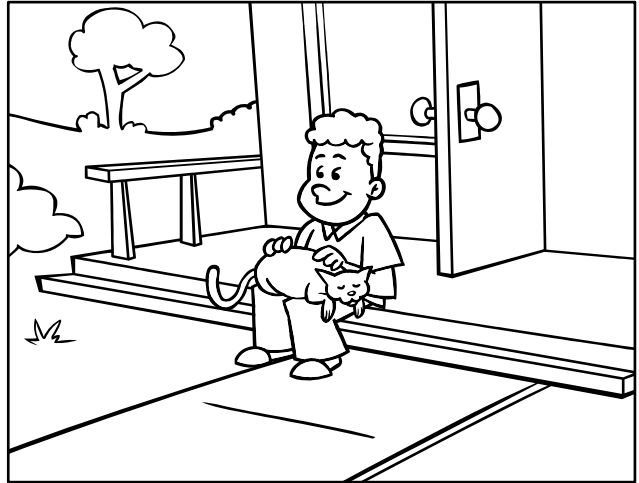

I have a cat in my family.

1

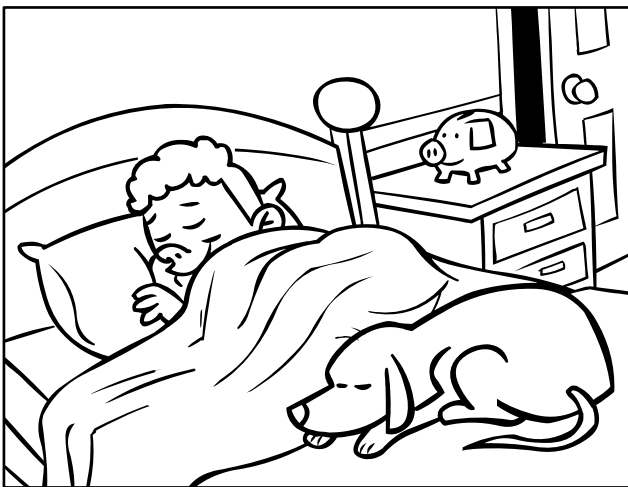

I have a dog in my family.

2

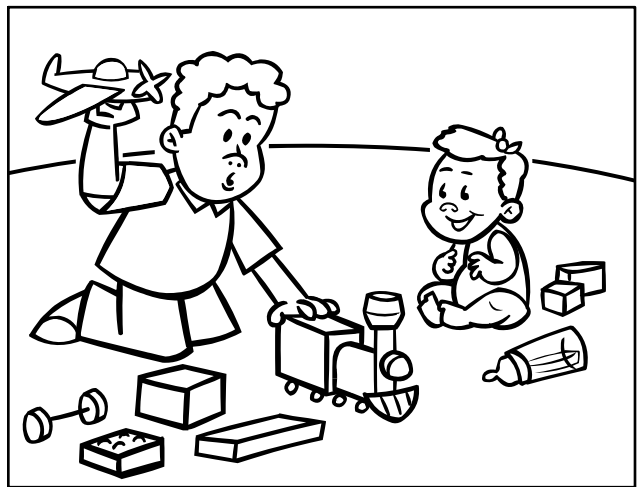

I have a baby sister  
in my family.

3



We are a family!

4

Who is in the family?

\_\_\_\_\_

-----

\_\_\_\_\_

-----

\_\_\_\_\_

5

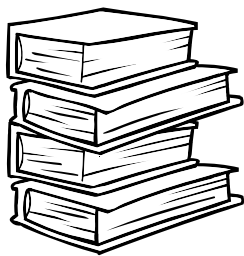

## Naming Capital Letters and Identifying Pictures with Same Beginning Sounds

**Directions:** Look at the letters. Circle all the capital letters. Then say each letter name aloud.

r	V	p	A	S
---	---	---	---	---

**Directions:** Say the name of each picture aloud. Then circle the picture that has the same beginning sound as the first picture.

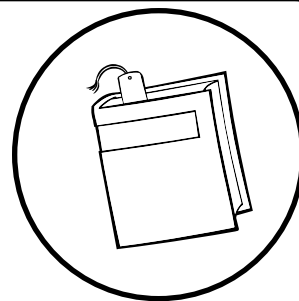
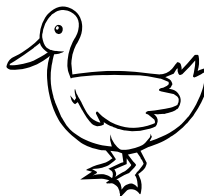
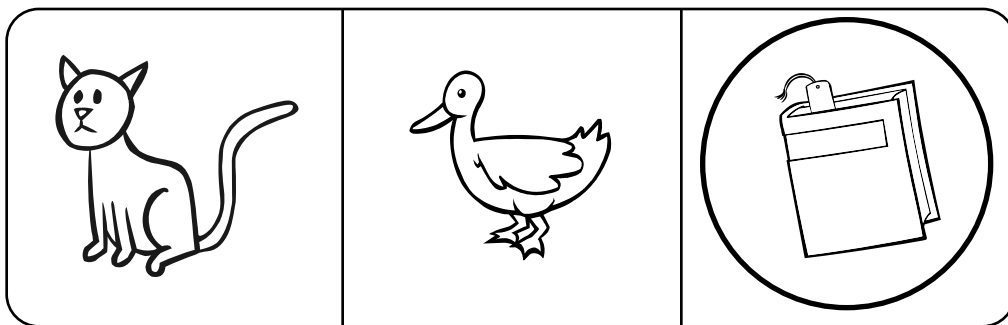
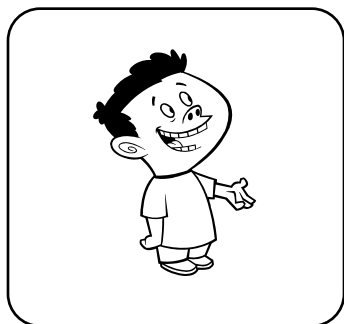

**Directions:** Say the name of each picture aloud. Then circle the picture that rhymes with the first picture.



**Directions:** Cut out the pages and put them in order. Staple the pages together. Then read the story and answer the question.

## In My Family

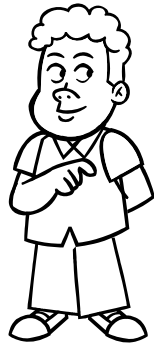

by Nicole Mead

Name \_\_\_\_\_

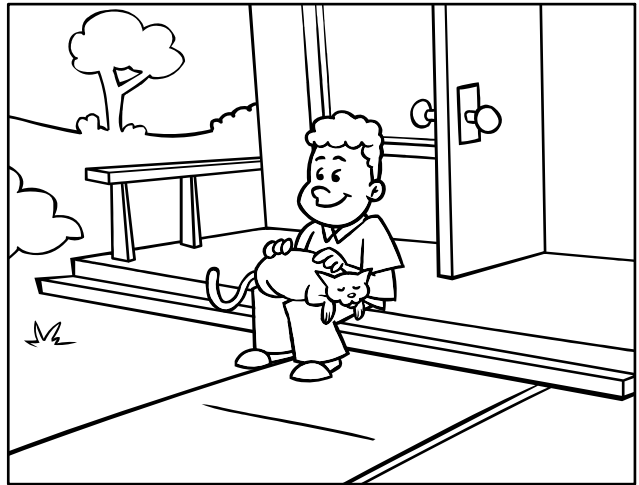

I have a cat in my family.

1

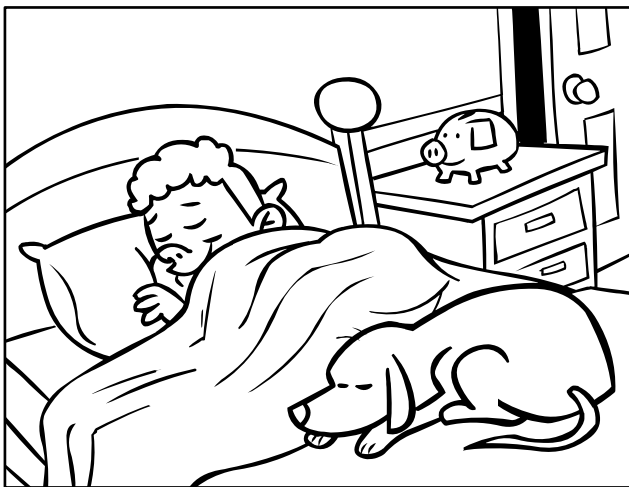

I have a dog in my family.

2

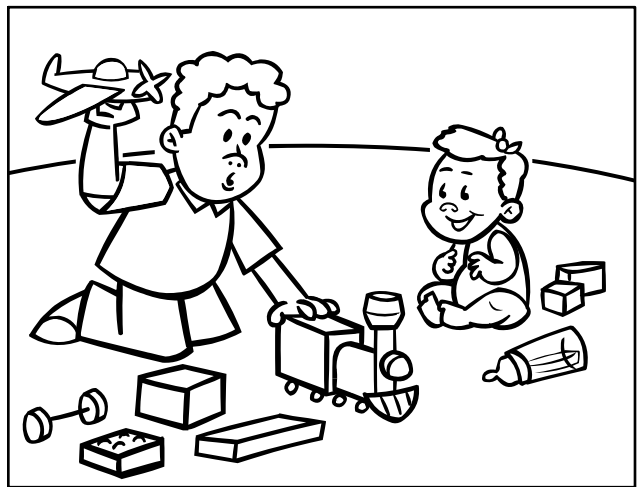

I have a baby sister  
in my family.

3

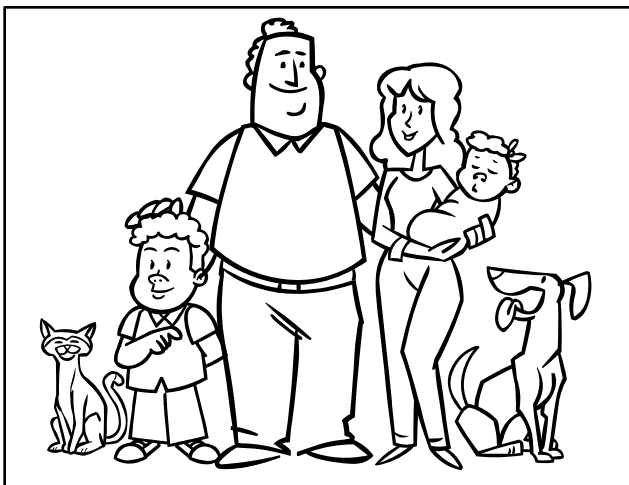

We are a family!

4

Who is in the family?

**Pictures  
will vary.**

\_\_\_\_\_  
\_\_\_\_\_  
**Mom, Dad, brother,**

\_\_\_\_\_  
\_\_\_\_\_  
**sister, dog, and cat**

5

# h j k m



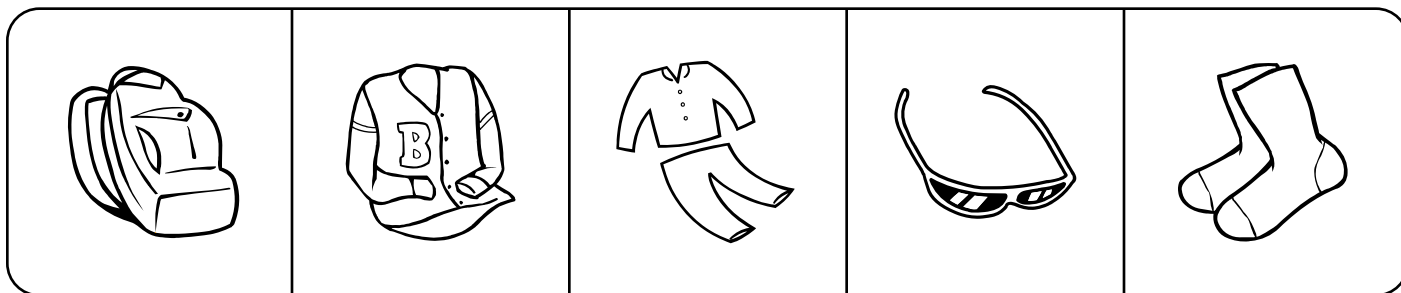

## Sorting Pictures into Categories

**Directions:** Look at the pictures. Say the name of each picture aloud. Then circle the pictures that have two syllables.

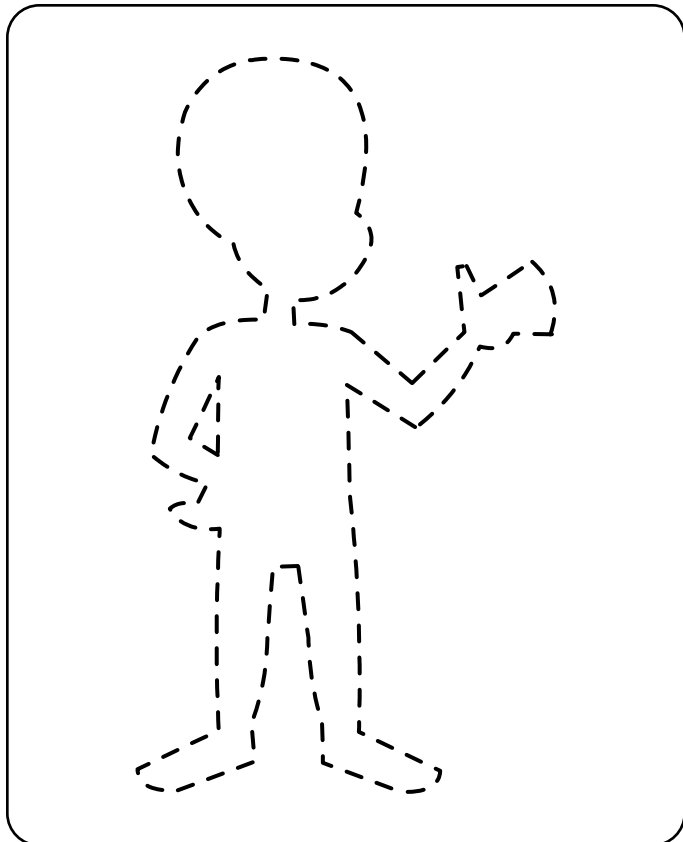

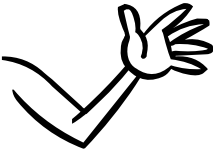
**Directions:** Cut out each picture. Then paste each picture in the correct box.

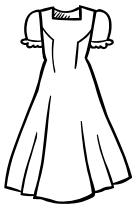

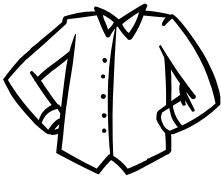
 head	 arm	 shoes	 hat
 dress	 leg	 feet	 shirt



# h j k m



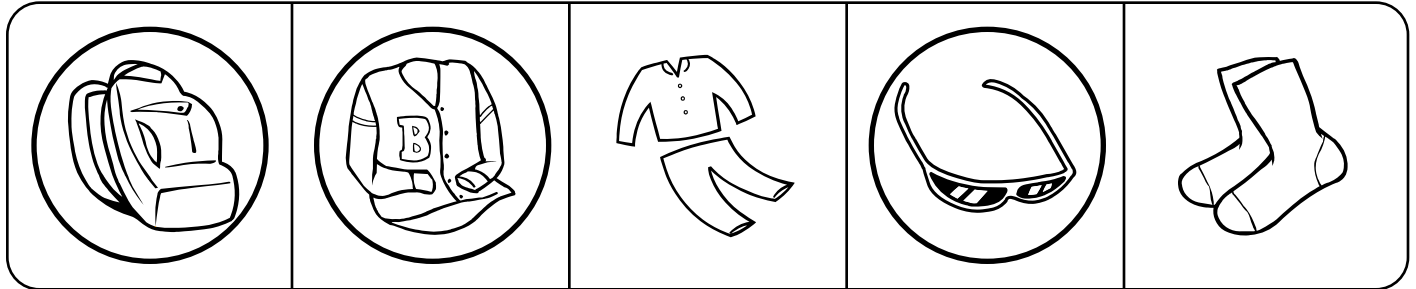

## Sorting Pictures into Categories

**Directions:** Look at the pictures. Say the name of each picture aloud. Then circle the pictures that have two syllables.

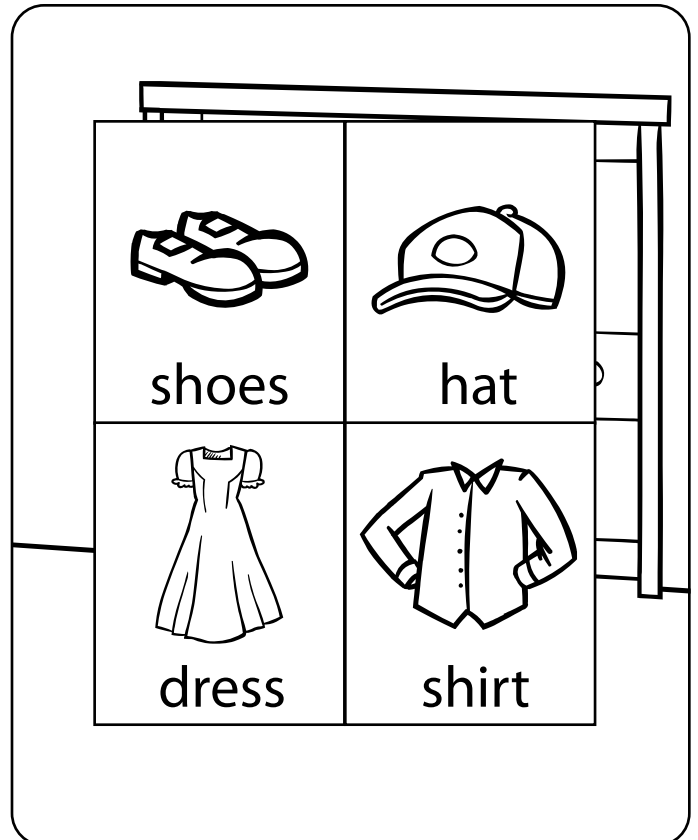
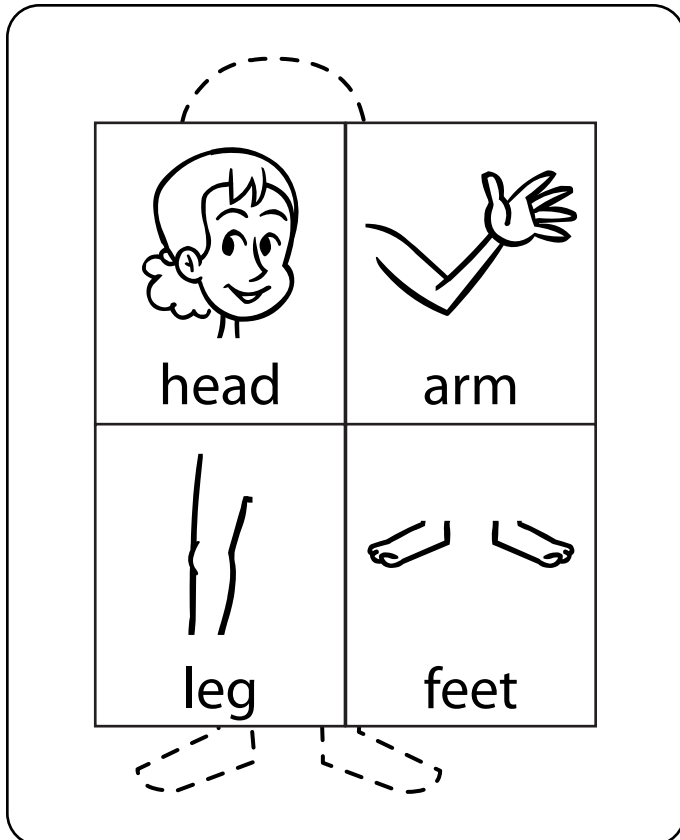

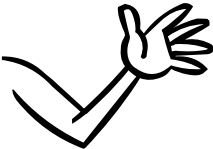
**Directions:** Cut out each picture. Then paste each picture in the correct box.

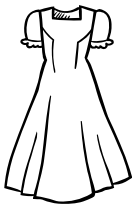

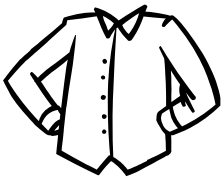
 head	 arm	 shoes	 hat
 dress	 leg	 feet	 shirt



## Recognizing Capital and Lowercase Letters

**Directions:** Draw a line from each capital letter to the matching lowercase letter.

**D****a****G****h****H****f****A****b****E****d****B****e****F****c****C****g**

**Directions:** Say the name of each picture aloud. Then circle the pictures that have the same beginning sound as the first picture.

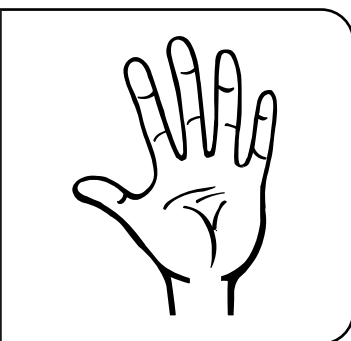
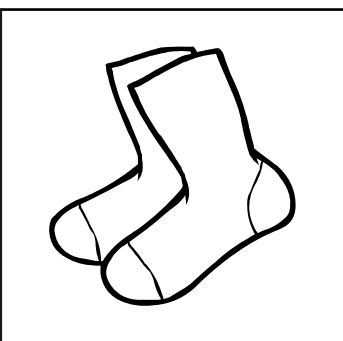
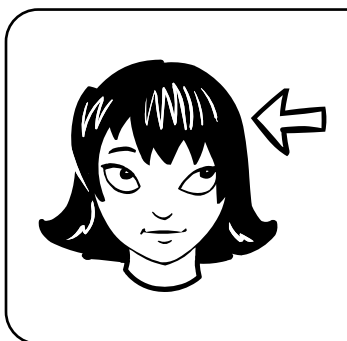
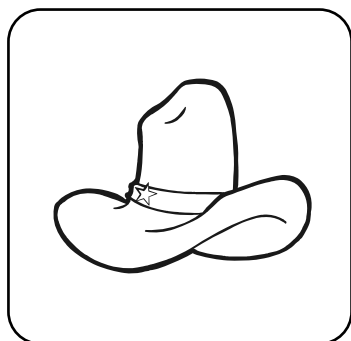

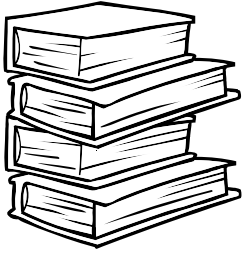

## Recognizing Capital and Lowercase Letters

**Directions:** Draw a line from each capital letter to the matching lowercase letter.

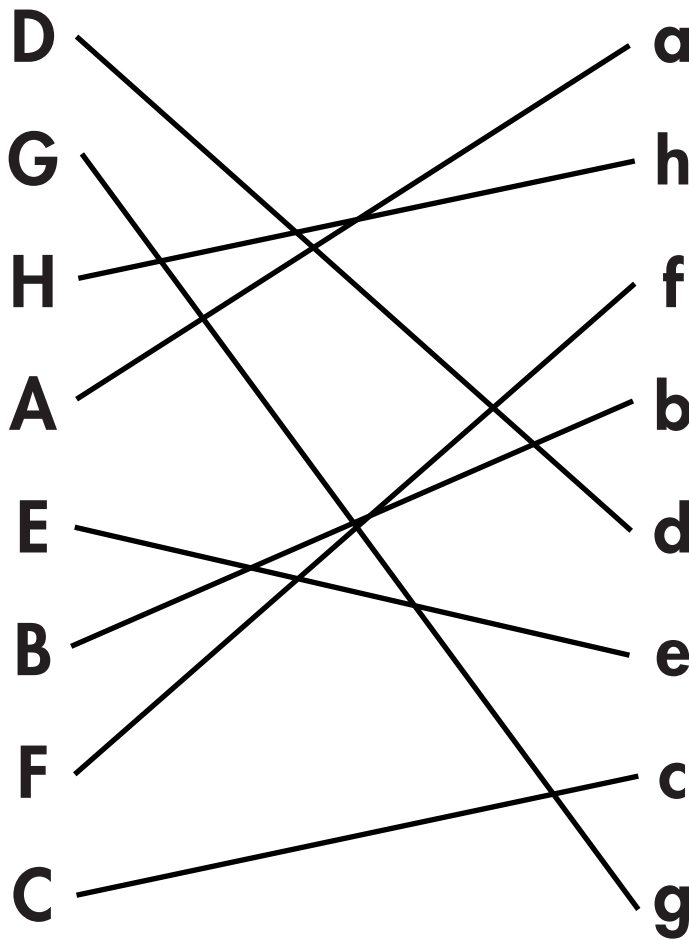

**Directions:** Say the name of each picture aloud. Then circle the pictures that have the same beginning sound as the first picture.

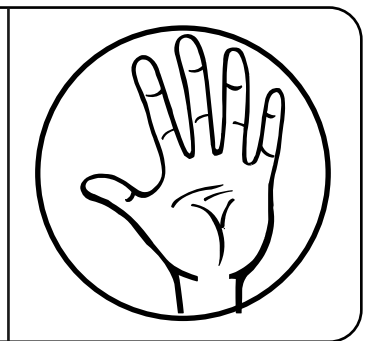
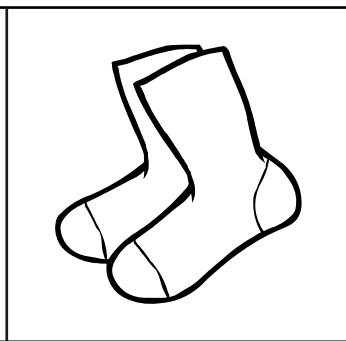
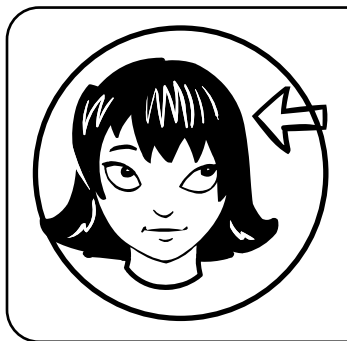
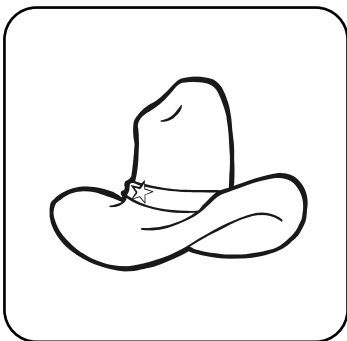

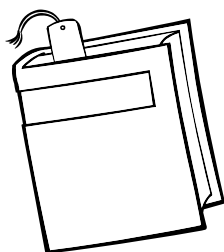

## Answering Questions about a Main Character

**Directions:** Cut out the pages and put them in order. Staple the pages together. Then read the story and answer the question.

### Lee Helps Mom

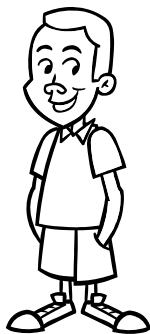

by Rene Holden

Name \_\_\_\_\_



Lee likes to help Mom.

1

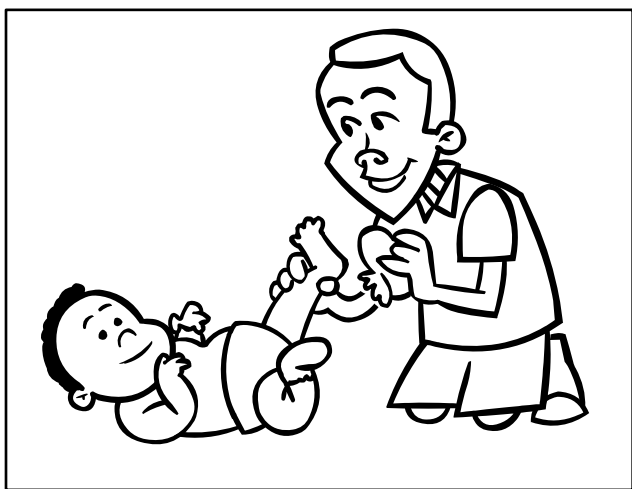

Lee puts shoes on the baby.

2



Lee puts the coat in the closet.

3

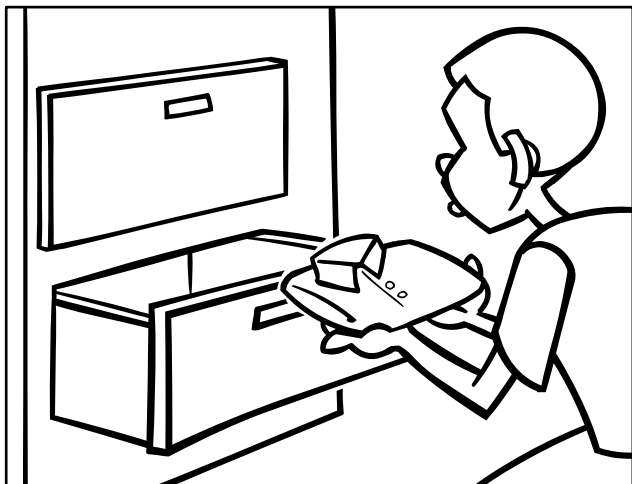

Lee puts the shirt  
in the drawer.

4

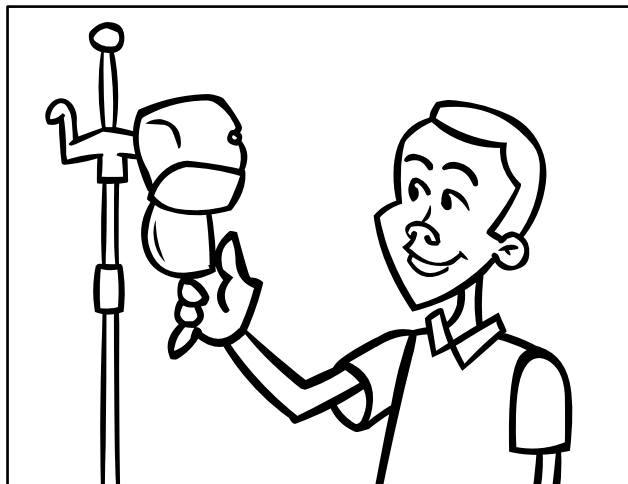

Lee puts the hat  
on the hook.

5



Lee puts his arms  
around Mom!

6

Who is this story about?

---

---

---

7

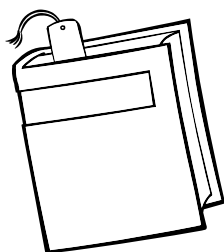

## Answering Questions about a Main Character

**Directions:** Cut out the pages and put them in order. Staple the pages together. Then read the story and answer the question.

### Lee Helps Mom

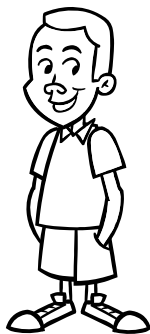

by Rene Holden

Name \_\_\_\_\_



Lee likes to help Mom.

1

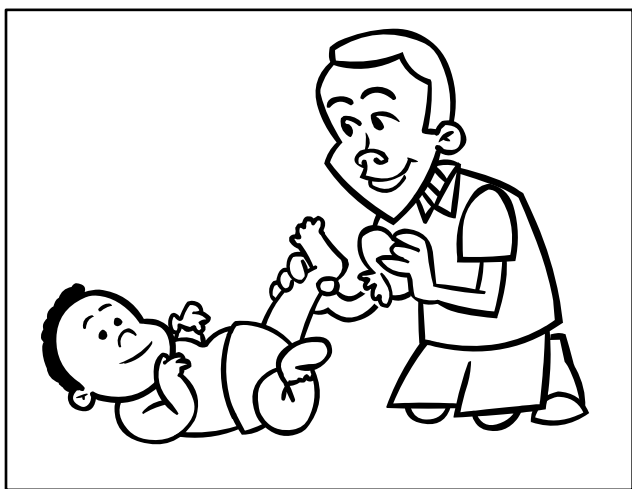

Lee puts shoes on the baby.

2



Lee puts the coat in the closet.

3

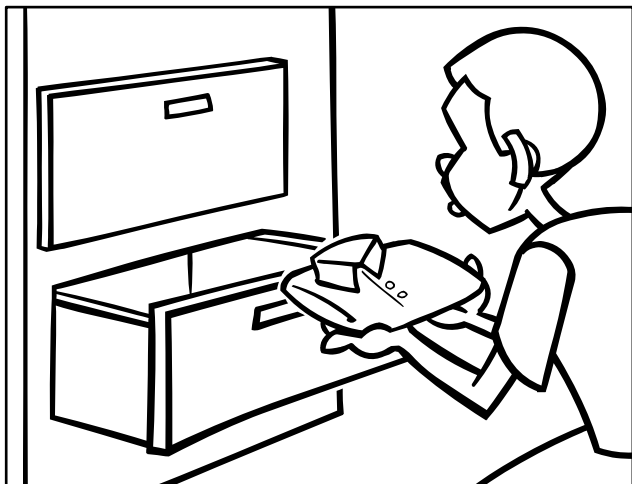

Lee puts the shirt  
in the drawer.

4

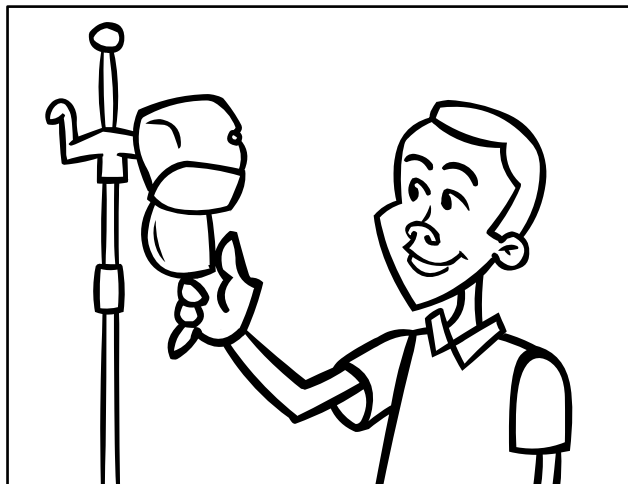

Lee puts the hat  
on the hook.

5



Lee puts his arms  
around Mom!

6

Who is this story about?

**Pictures  
will vary.**

\_\_\_\_\_  
-----  
**Lee**

7



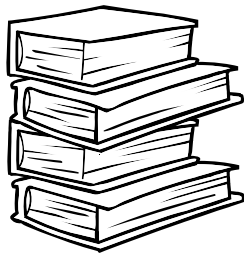

## Blending Onsets and Rimes into Whole Words

**Directions:** Look at the pictures. Say the name of each picture aloud. Then circle the pictures that have two syllables.

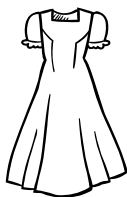
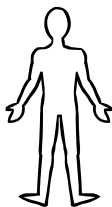

**Directions:** Look at the pictures. Say what the picture is out loud. Then paste two pictures that rhyme in each box.

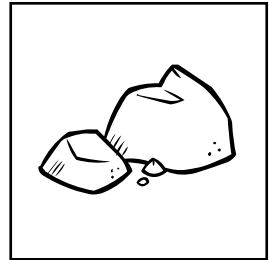
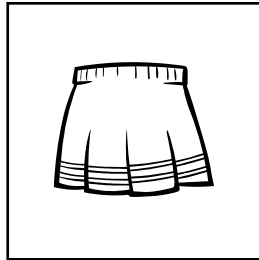
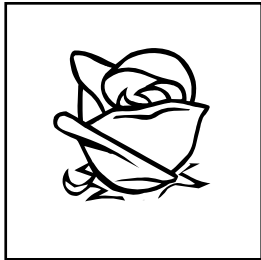
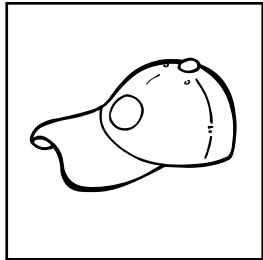
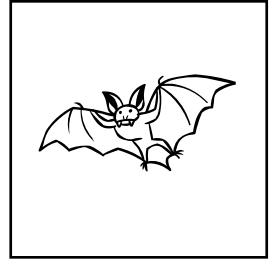
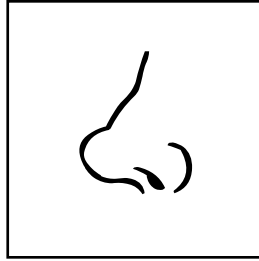
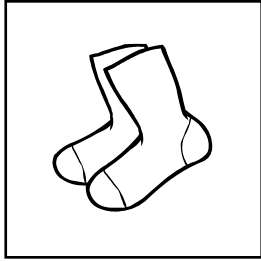
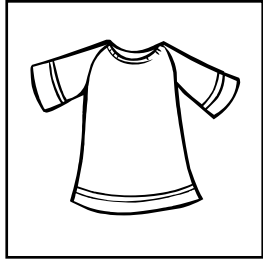

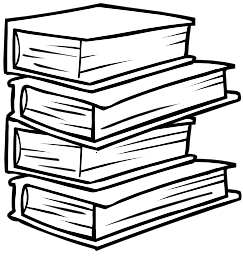

## Blending Onsets and Rimes into Whole Words

**Directions:** Look at the pictures. Say the name of each picture aloud. Then circle the pictures that have two syllables.

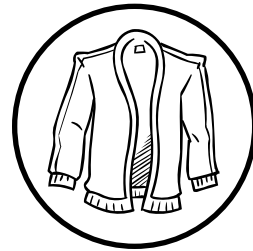
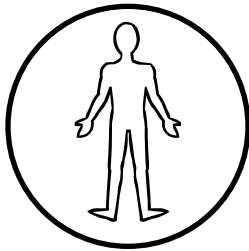

**Directions:** Look at the pictures. Say what the picture is out loud. Then paste two pictures that rhyme in each box.

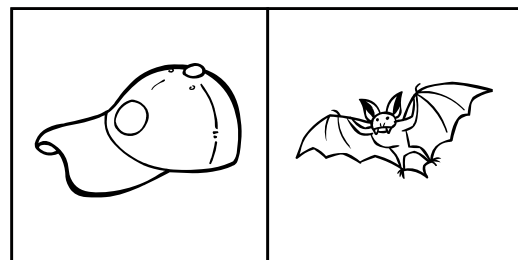
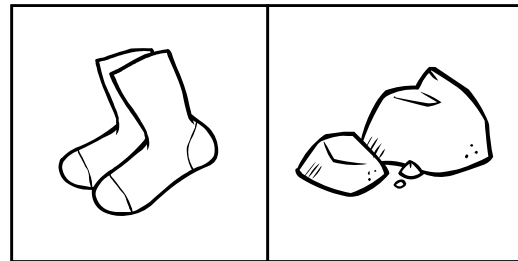
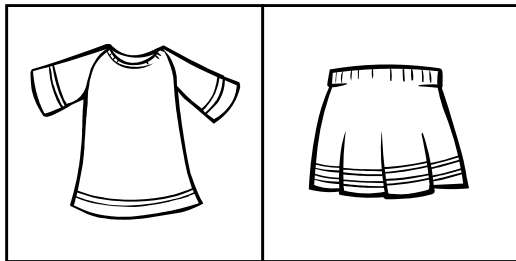

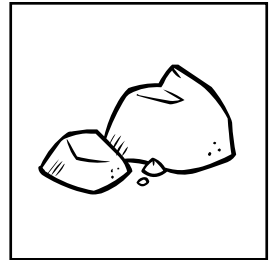
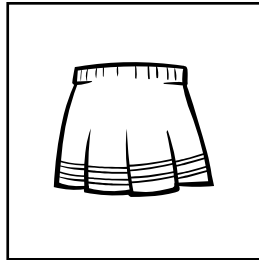
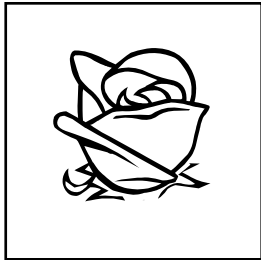
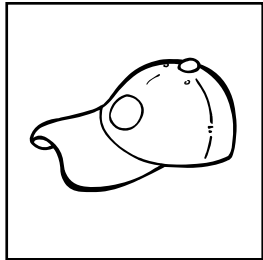
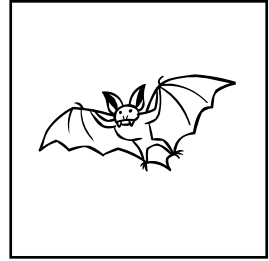
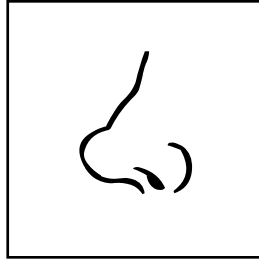
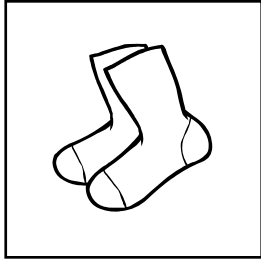
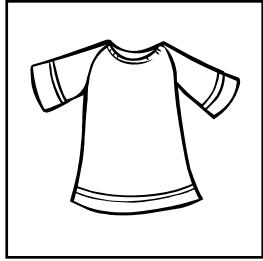

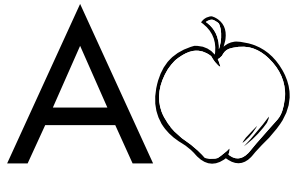

## Naming Capital and Lowercase Letters

**Directions:** Look at the pictures. Circle the pictures that show parts of the body.



**Directions:** Look at the pictures. Say the name of each picture aloud. Then circle the pictures that have two syllables.

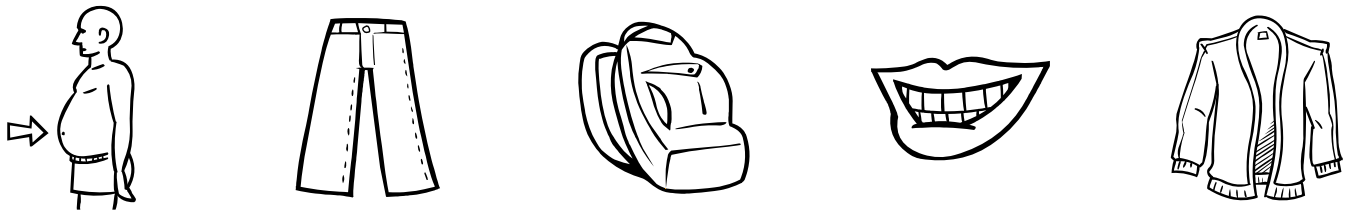

**Directions:** Look at the letters. Circle all the lowercase letters. Then say each letter name aloud.

A	b	C	D
e	F	g	h

**Directions:** Cut out the pages and put them in order. Staple them together. Then read the story and answer the question.

## Kim and Dad



by Rene Holden

Name \_\_\_\_\_



Kim will play ball  
with Dad.

1

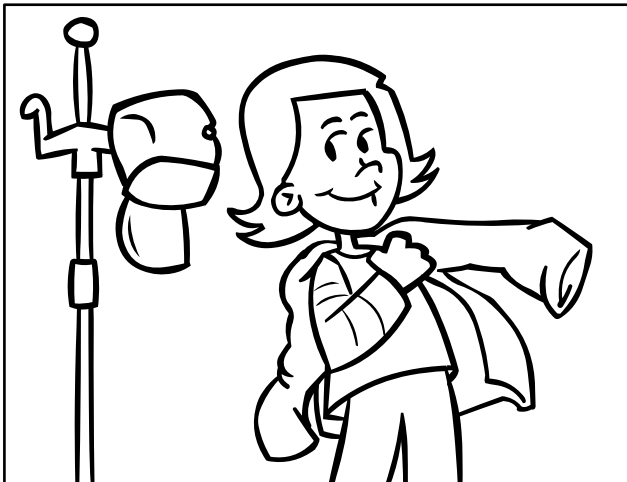

She gets her hat.  
She gets her coat.

2

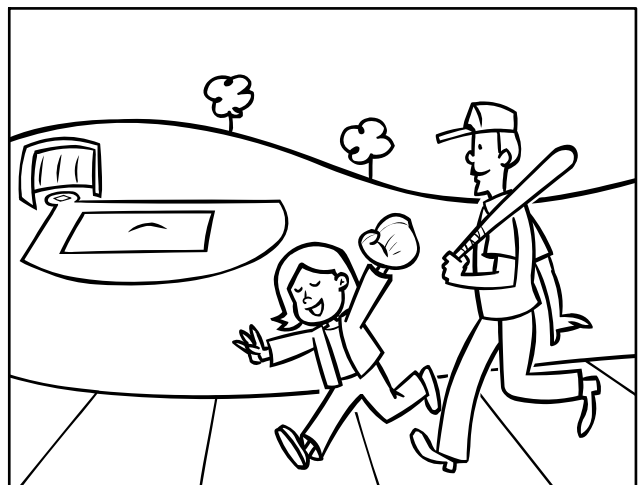

Kim and Dad go to the  
park. They play ball.

3

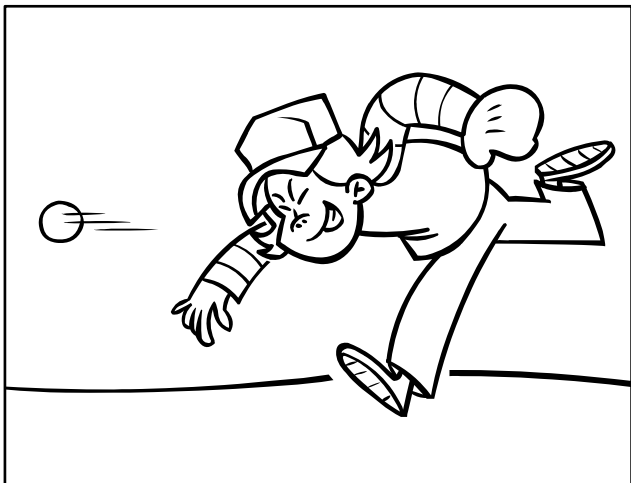

Kim likes playing  
ball at the park.

4

Who is this story about?

---

---

---

5

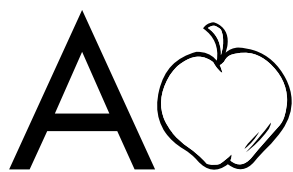

## Naming Capital and Lowercase Letters

**Directions:** Look at the pictures. Circle the pictures that show parts of the body.

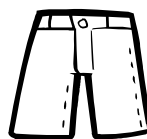
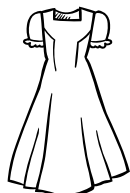
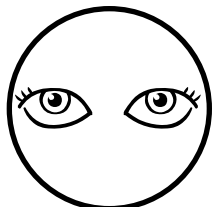

**Directions:** Look at the pictures. Say the name of each picture aloud. Then circle the pictures that have two syllables.

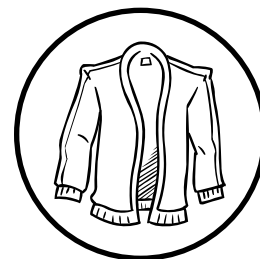
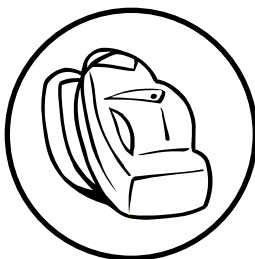
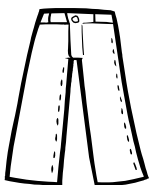
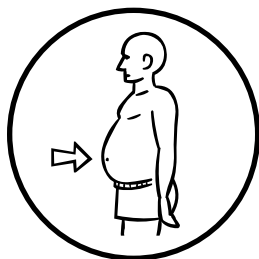

**Directions:** Look at the letters. Circle all the lowercase letters. Then say each letter name aloud.

A	b	C	D
e	F	g	h



**Directions:** Cut out the pages and put them in order. Staple them together. Then read the story and answer the question.

## Kim and Dad



by Rene Holden

Name \_\_\_\_\_



Kim will play ball  
with Dad.

1

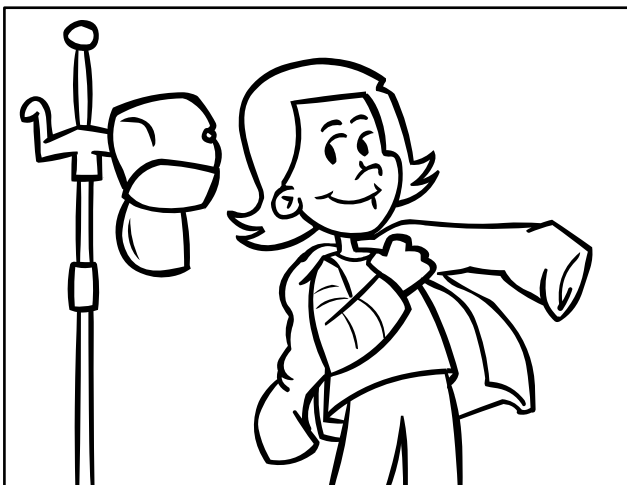

She gets her hat.  
She gets her coat.

2

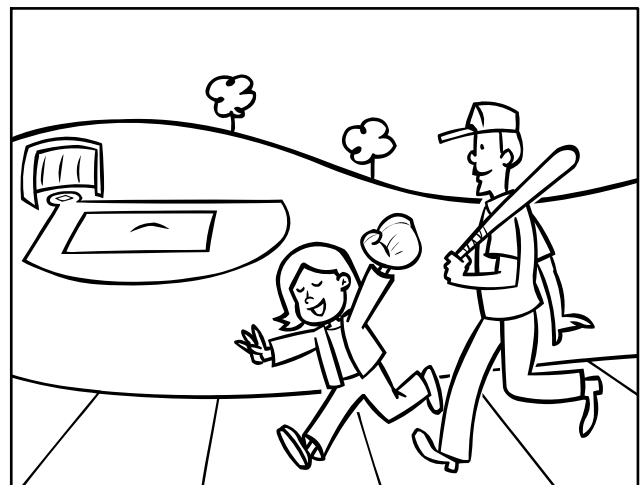

Kim and Dad go to the  
park. They play ball.

3

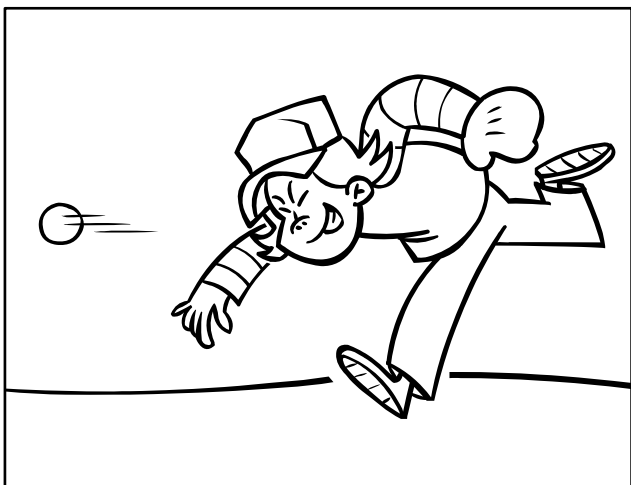

Kim likes playing  
ball at the park.

4

Who is this story about?

**Pictures  
will vary.**

\_\_\_\_\_  
--- **Kim and Dad** ---  
\_\_\_\_\_

5

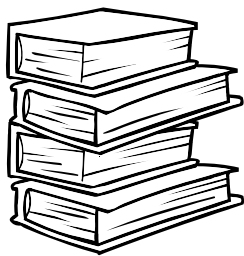

## Naming Capital and Lowercase Letters

**Directions:** Look at the letters. Circle all the lowercase letters. Then say each letter name aloud.

P   **a**   H   j   o   C   i   F  
 b   L   n   E   k   G   M   D

**Directions:** Look at the capital letter. Then circle the matching lowercase letter.

A	<b>a</b>	e	d	f
B	r	p	b	o
C	z	x	c	j
E	c	m	l	e
F	f	h	j	k

**Directions:** Say the name of each picture aloud. Then circle the picture that has the same beginning sound as the first picture.

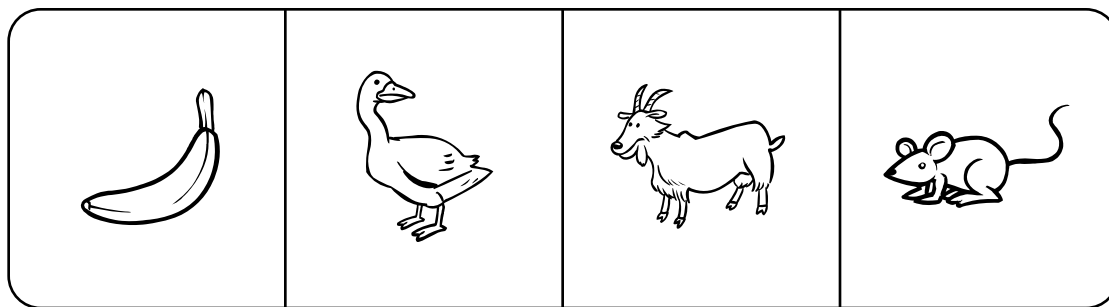
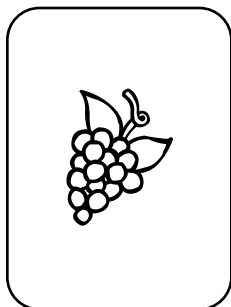
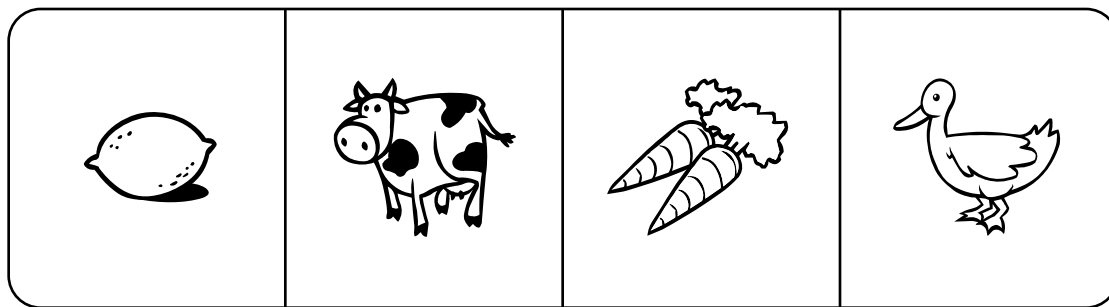
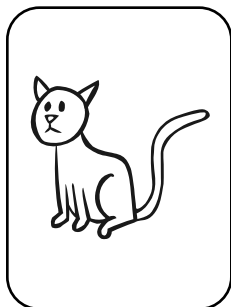

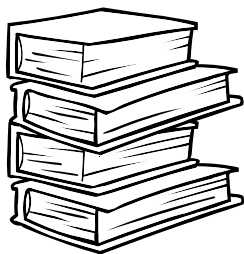

## Naming Capital and Lowercase Letters

**Directions:** Look at the letters. Circle all the lowercase letters. Then say each letter name aloud.

P   a   H   j   o   C   i   F  
 b   L   n   E   k   G   M   D

**Directions:** Look at the capital letter. Then circle the matching lowercase letter.

A	a	e	d	f
B	r	p	b	o
C	z	x	c	j
E	c	m	l	e
F	f	h	j	k

**Directions:** Say the name of each picture aloud. Then circle the picture that has the same beginning sound as the first picture.

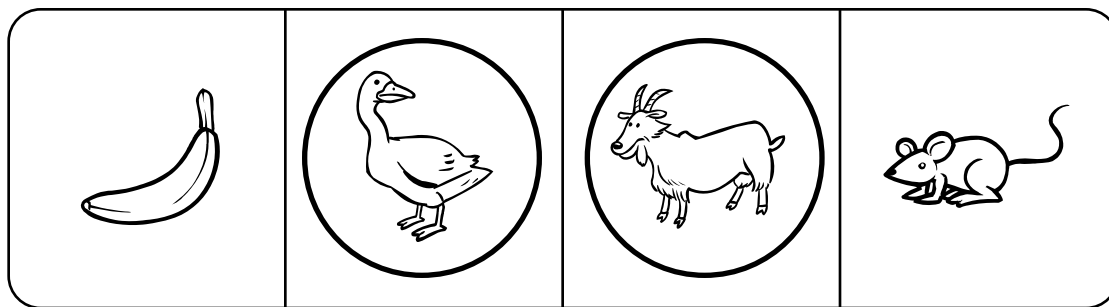
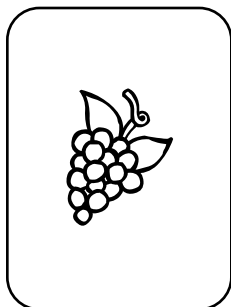
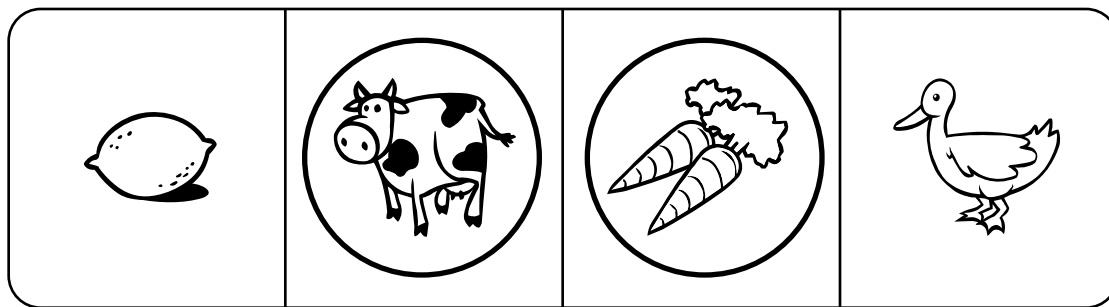
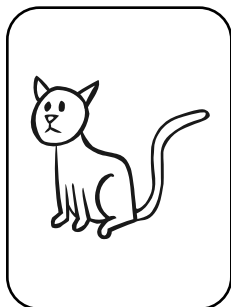

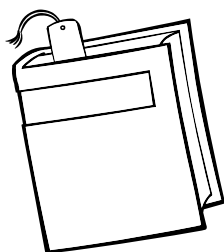

## Answering Questions about Main Characters

**Directions:** Cut out the pages and put them in order. Staple the pages together. Then read the story and answer the question.

### Little Red Hen Makes Soup

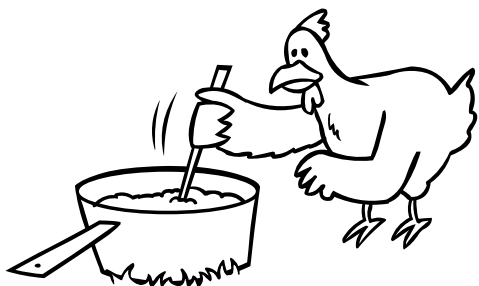

by Barbara Davis-Pyles

Name \_\_\_\_\_

AH-  
CHOO!

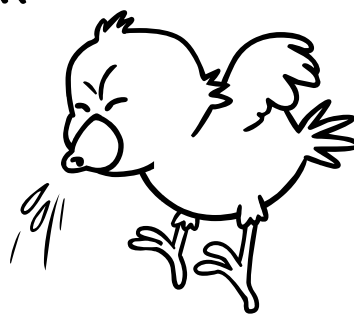

Achoo! Little Yellow Chick  
is sick, sick, sick!

1



Little Red Hen makes soup,  
quick, quick, quick!

2

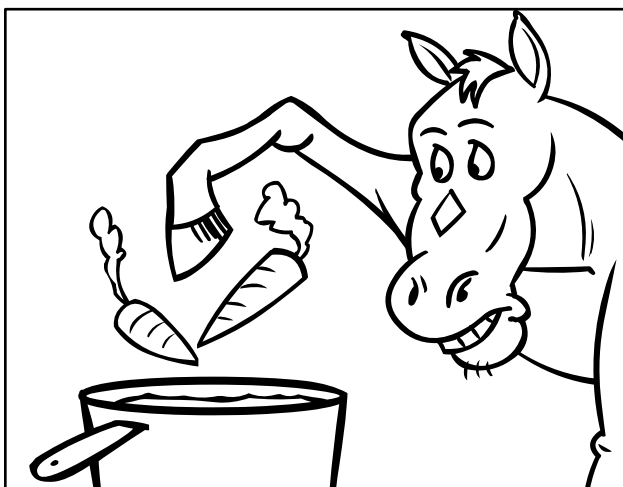

Grey Horse adds  
corn and carrots.

3

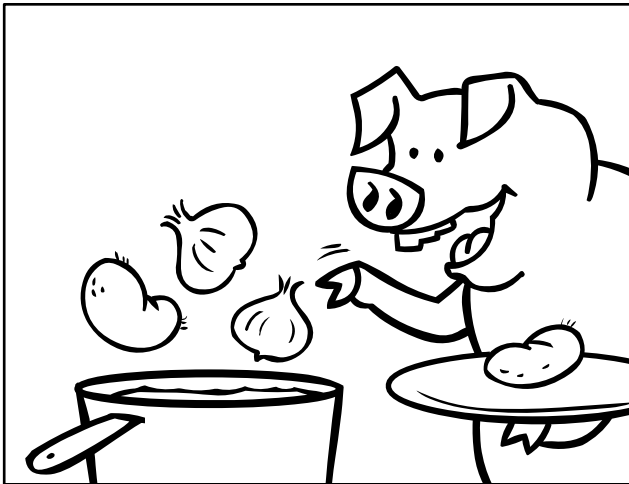

Pink Pig adds potatoes and onions.

4

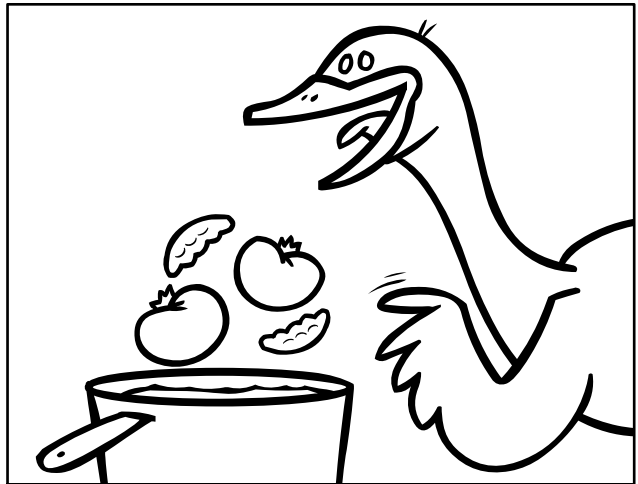

White Goose adds tomatoes and peas.

5

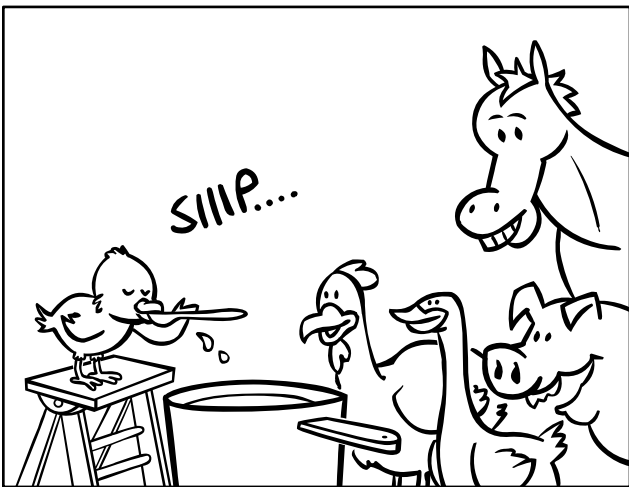

Take a sip.  
Yum, yum, yum!

6

Who helps you when you are sick?

---

---

---

7



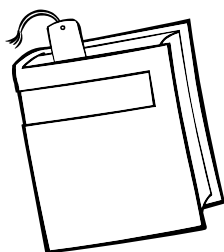

## Answering Questions about Main Characters

**Directions:** Cut out the pages and put them in order. Staple the pages together. Then read the story and answer the question.

### Little Red Hen Makes Soup

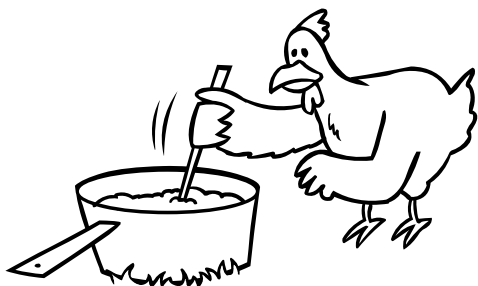

by Barbara Davis-Pyles

Name \_\_\_\_\_

AH-CHOO!

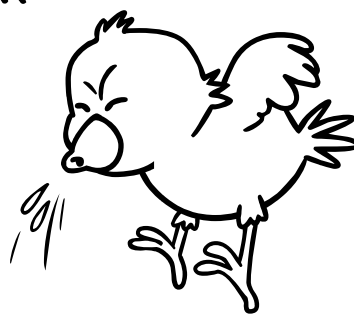

Achoo! Little Yellow Chick is sick, sick, sick!

1



Little Red Hen makes soup, quick, quick, quick!

2

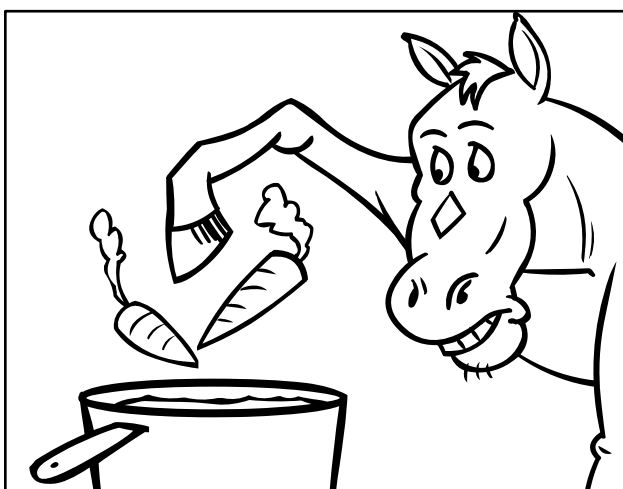

Grey Horse adds corn and carrots.

3

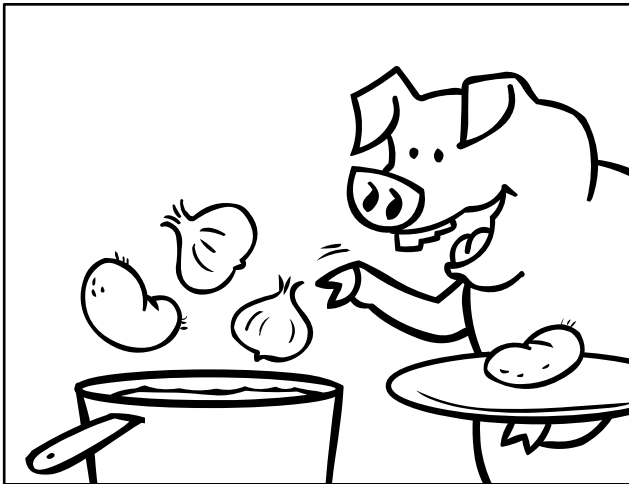

Pink Pig adds potatoes and onions.

4

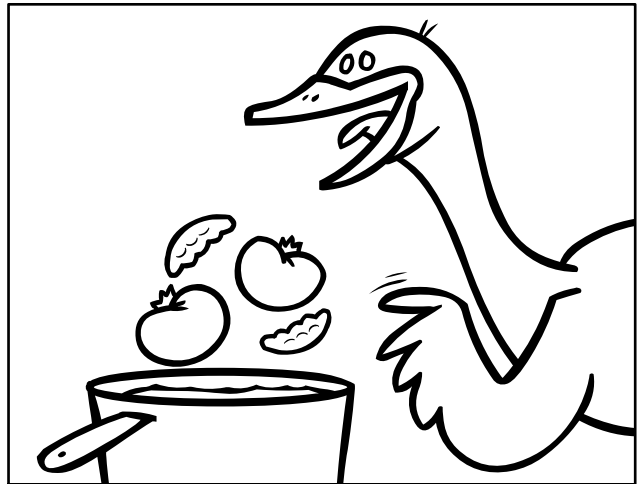

White Goose adds tomatoes and peas.

5



Take a sip.  
Yum, yum, yum!

6

Who helps you when you are sick?

**Pictures will vary.**

**Answers will vary.**

7

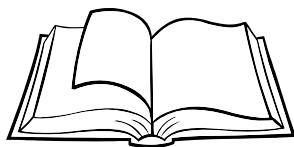

## Blending Phonemes into Words

**Directions:** Look at the pictures. Say the name of each picture aloud. Then draw a line to match the rhyming words.

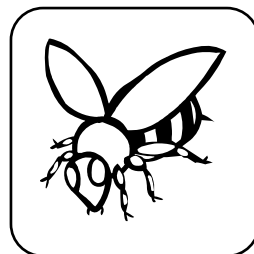
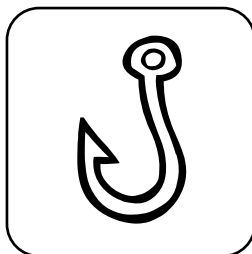
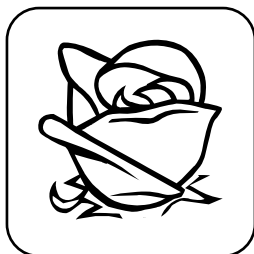
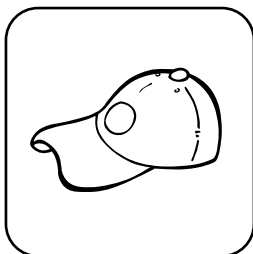
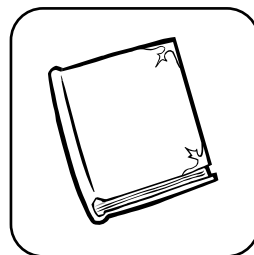
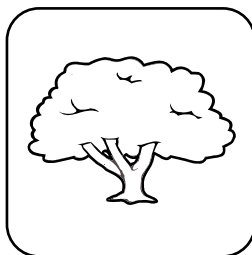
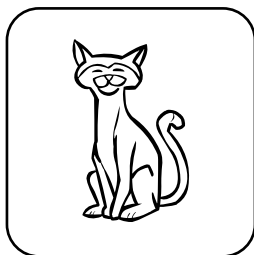

**Directions:** Cut out the puzzles. Say each sound as you build the puzzle. Then read the word aloud.

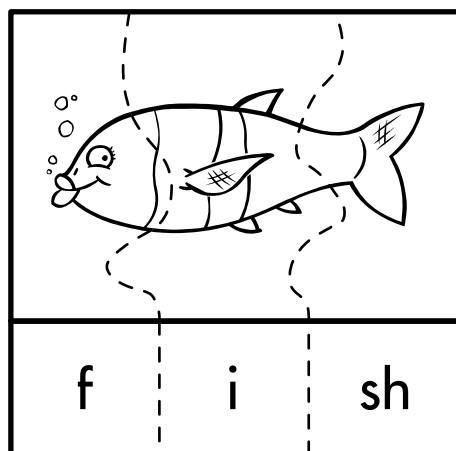

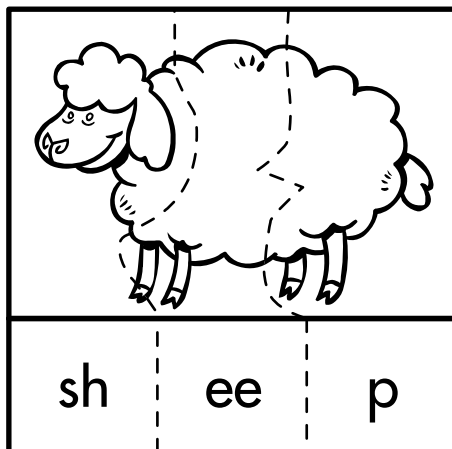
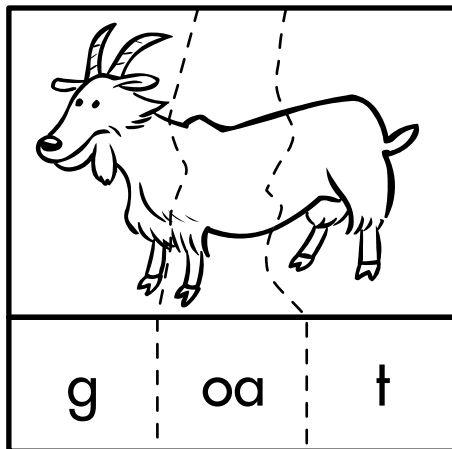
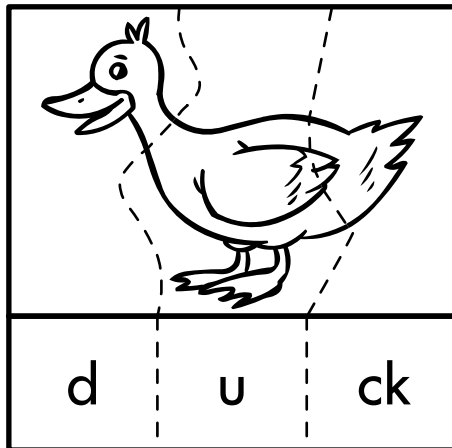



## Blending Phonemes into Words

**Directions:** Look at the pictures. Say the name of each picture aloud. Then draw a line to match the rhyming words.

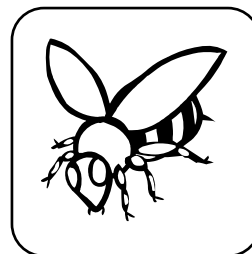
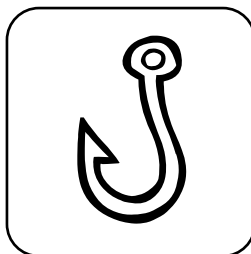
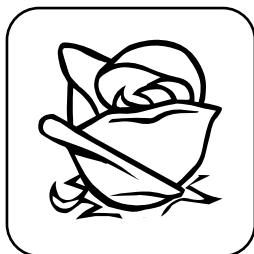
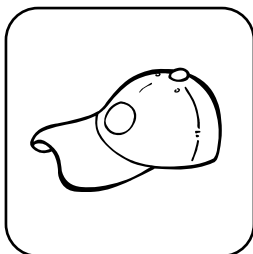
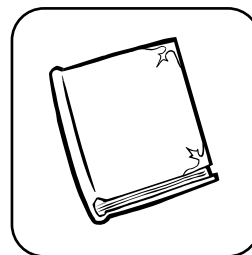
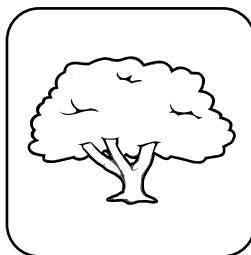
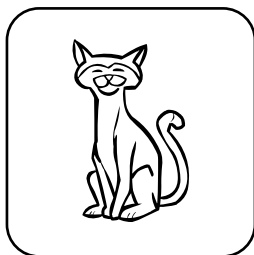

**Directions:** Cut out the puzzles. Say each sound as you build the puzzle. Then read the word aloud.

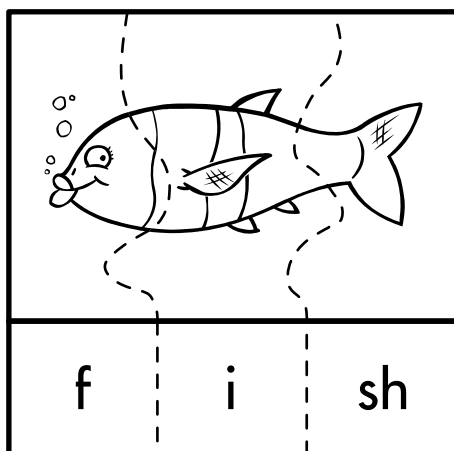

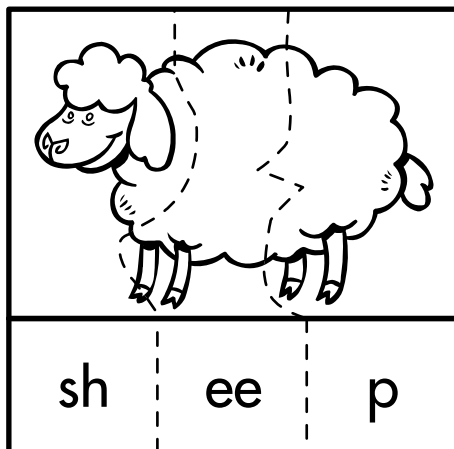
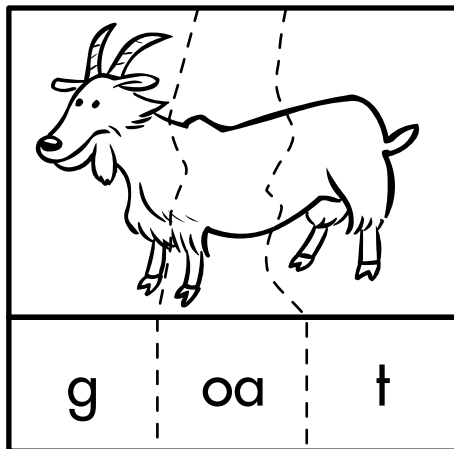
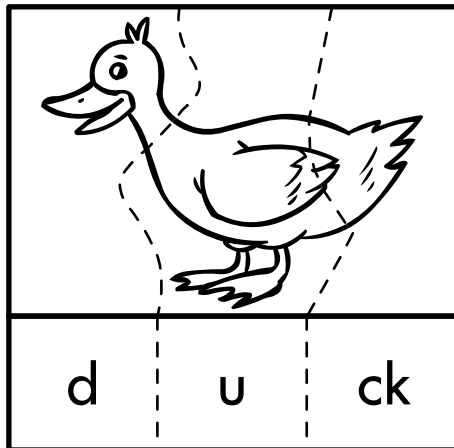



## Sorting Words into Categories and Segmenting Words into Phonemes

**Directions:** Cut out the pictures. Sort them into groups. Then paste.

Fruit

Animals

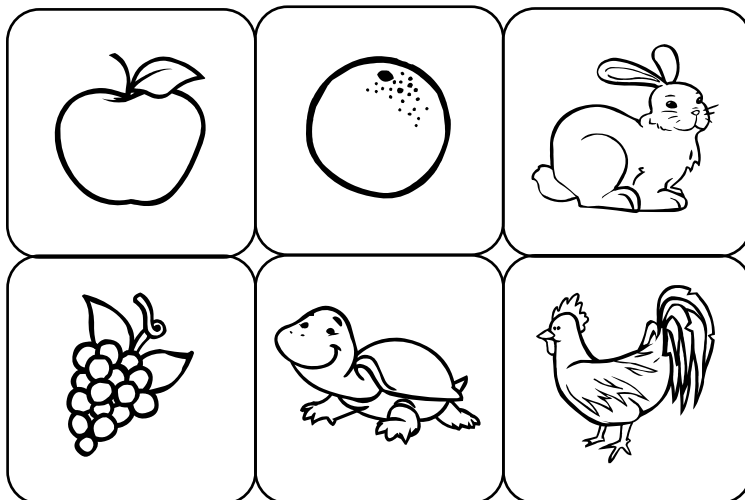
**Directions:** Cut out the puzzles. Say each sound as you build the puzzle. Then read the word aloud.



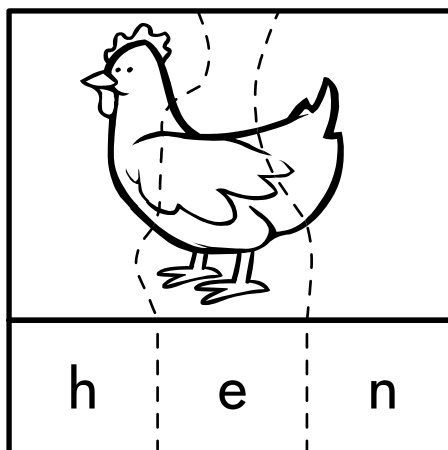
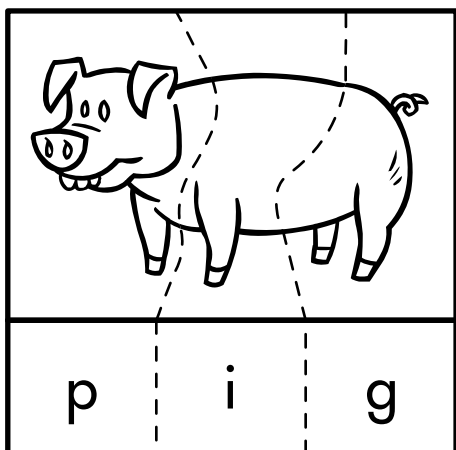
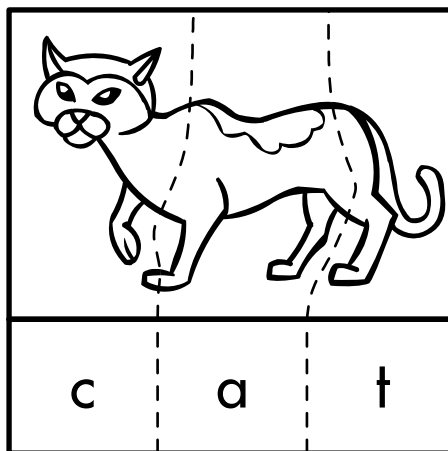
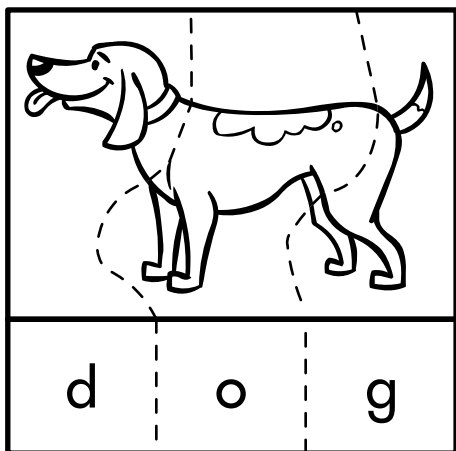



## Sorting Words into Categories and Segmenting Words into Phonemes

**Directions:** Cut out the pictures. Sort them into groups. Then paste.

### Fruit

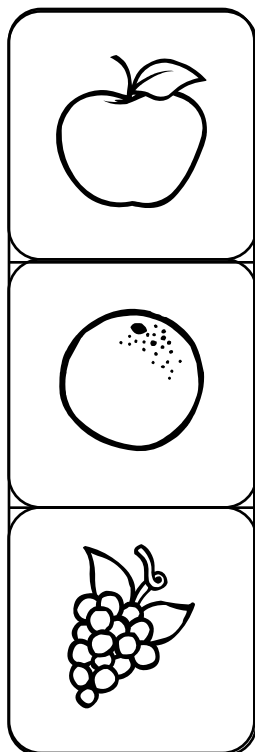

### Animals

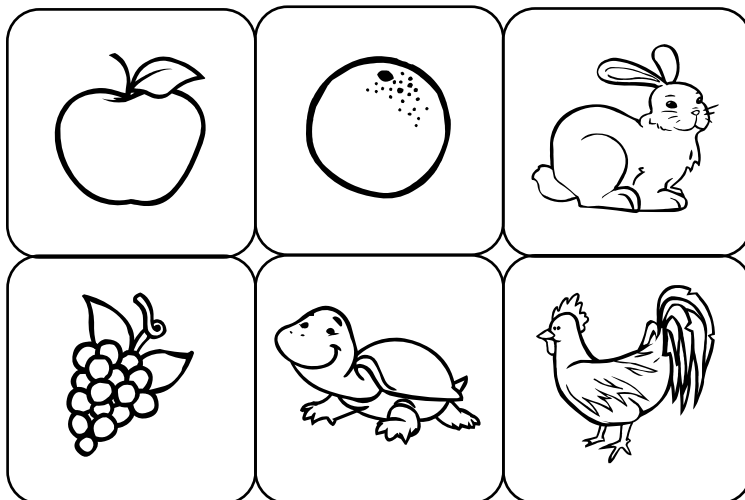
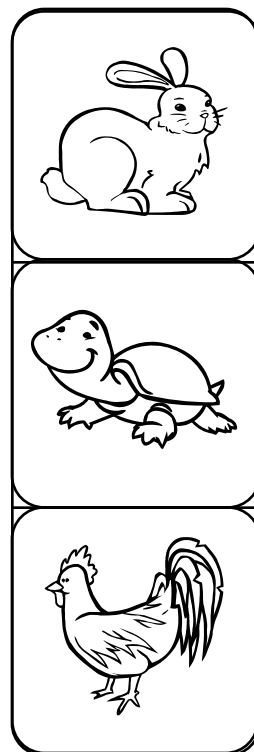

**Directions:** Cut out the puzzles. Say each sound as you build the puzzle. Then read the word aloud.

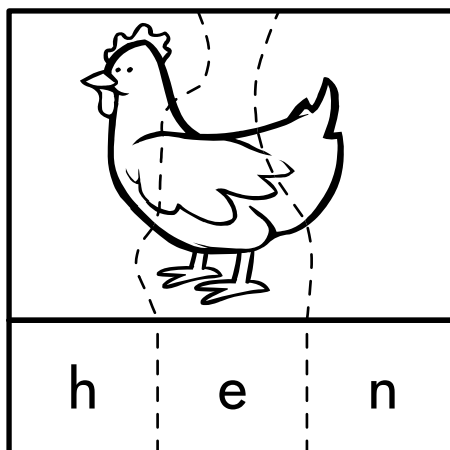
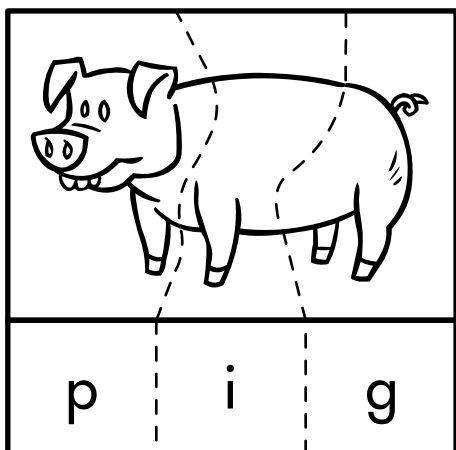
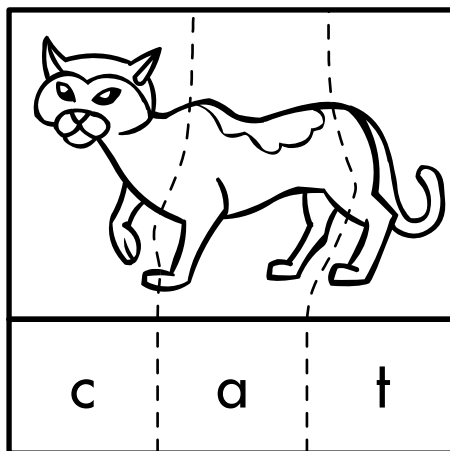
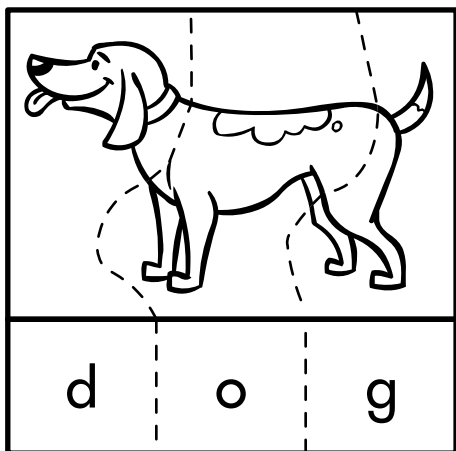

# aeiou

## Naming Capital and Lowercase Letters

**Directions:** Draw an X on the capital letters. Circle the lowercase letters.

f C A G h F E

b c D a B e d

**Directions:** Draw a picture for each question.

The  ran up the  .

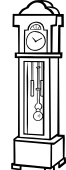
The  struck 1,

The  ran  .

Hickory Dickory Dock!

Who runs?

Where does he run?

**Directions:** Look at the pictures. Say the name of each picture aloud. Then circle the pictures that have the same beginning sound.

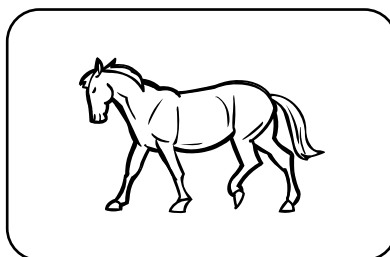
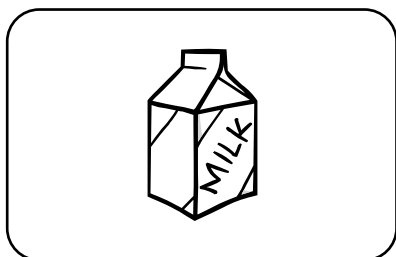
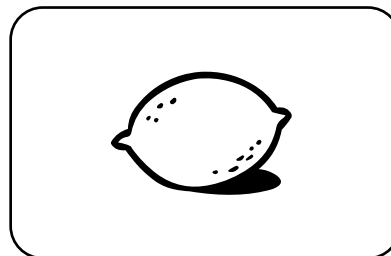
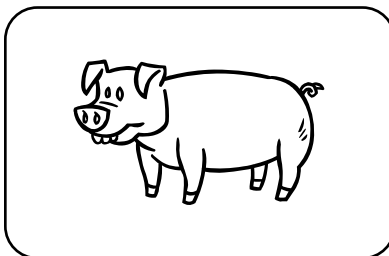

**Directions:** Draw a picture that rhymes with the picture below.

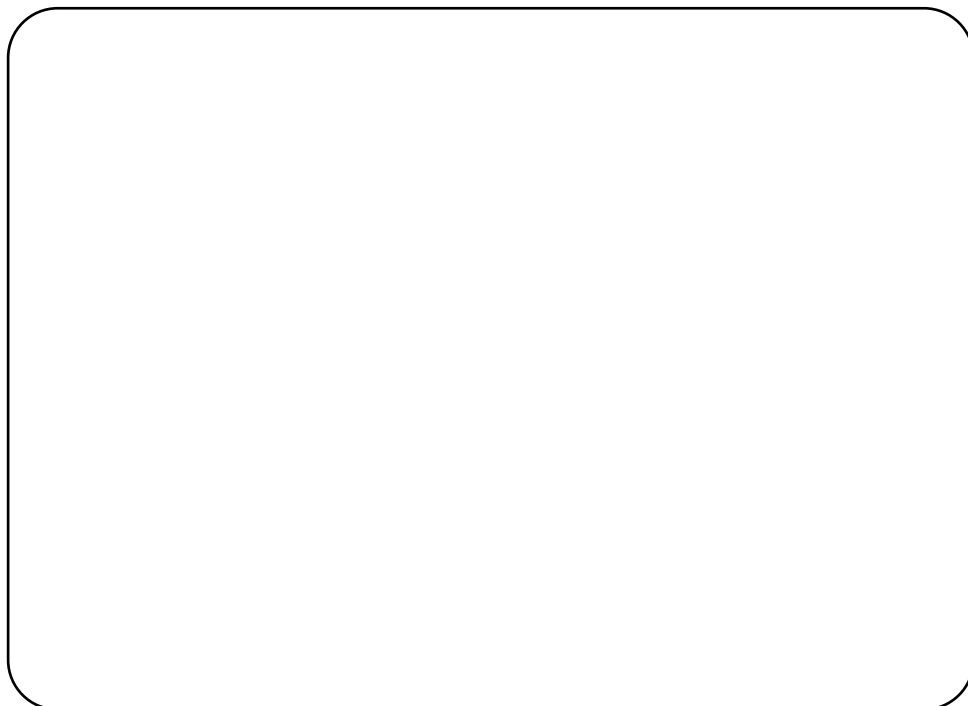
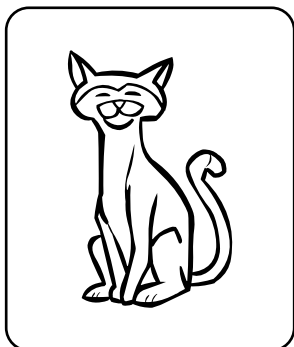

## aeiou

### Naming Capital and Lowercase Letters

**Directions:** Draw an X on the capital letters. Circle the lowercase letters.

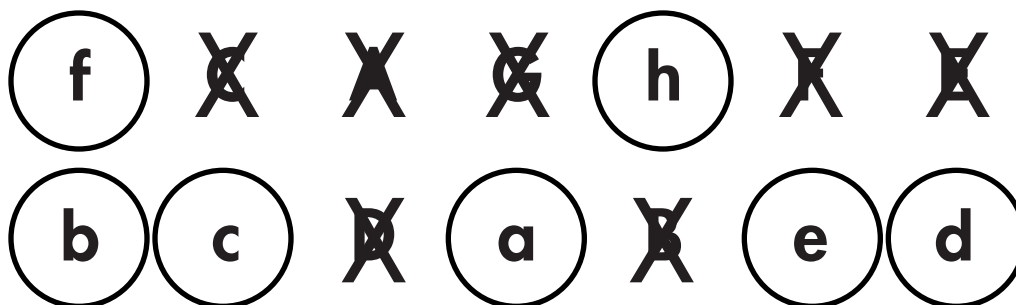

**Directions:** Draw a picture for each question.

The  ran up the  .

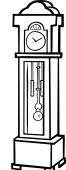
The  struck 1,

The  ran  .

Hickory Dickory Dock!

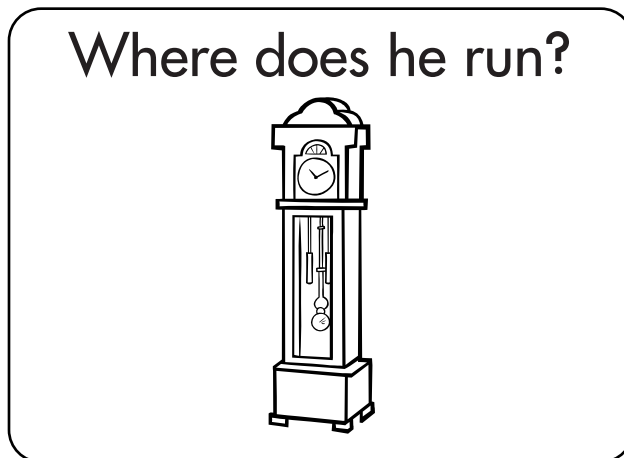

**Directions:** Look at the pictures. Say the name of each picture aloud. Then circle the pictures that have the same beginning sound.

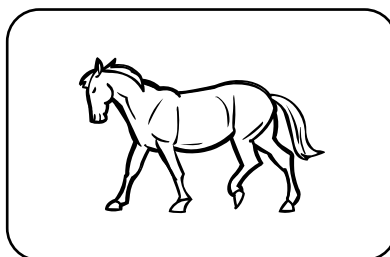
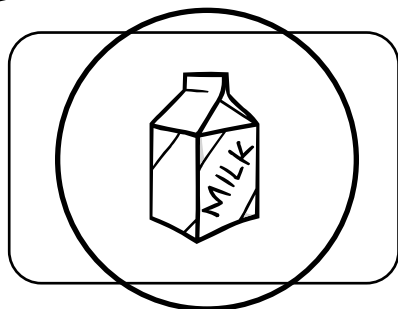
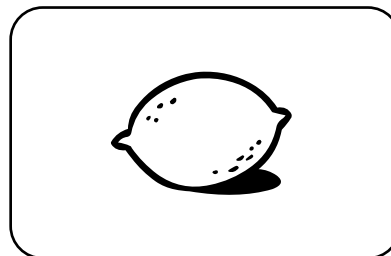
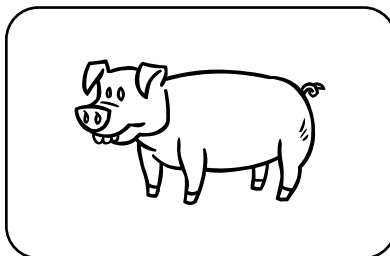
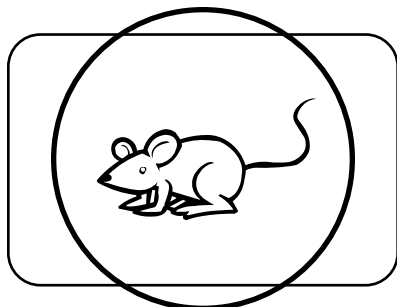

**Directions:** Draw a picture that rhymes with the picture below.

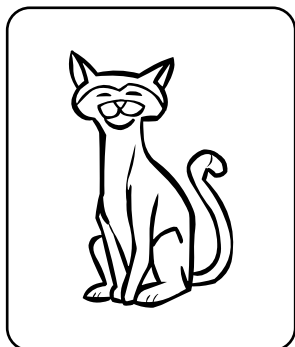

**Pictures will vary.**

# aeiou

## Naming Capital and Lowercase Letters

**Directions:** Look at the letters. Circle all the lowercase letters.

r M S E m R x

t Y q Z u P v

**Directions:** Draw a line to match the pictures that begin with the same sound.

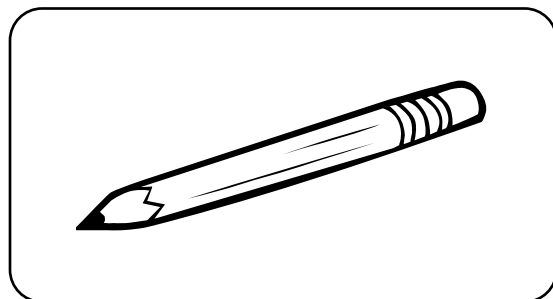
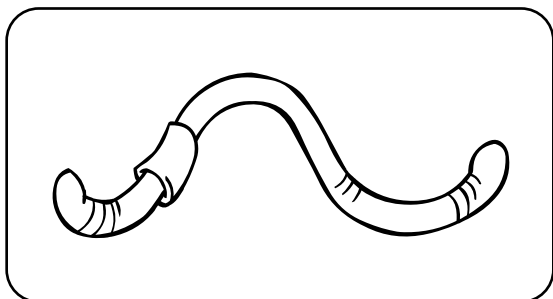
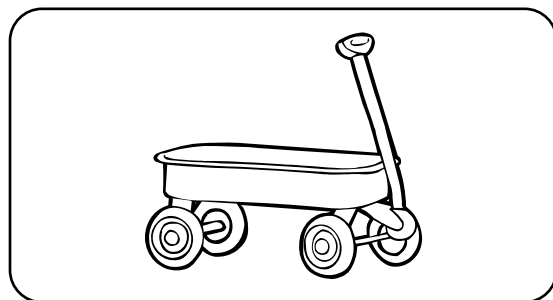
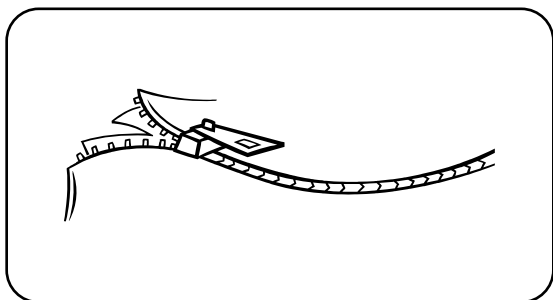
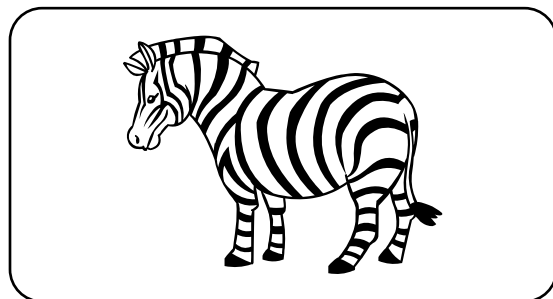
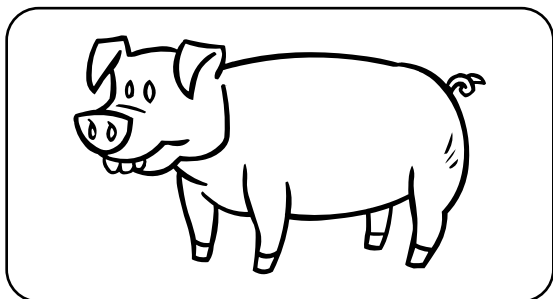

**Directions:** Cut out the puzzles. Say each sound as you build the puzzles. Then read the word aloud.

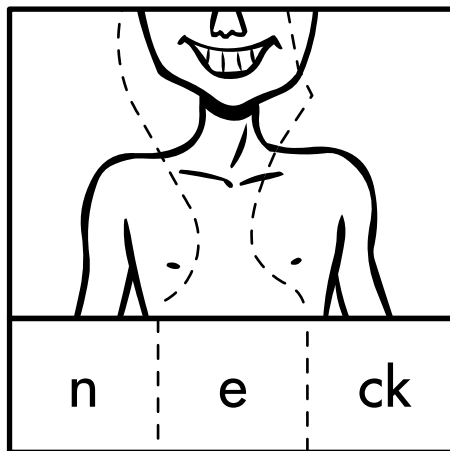
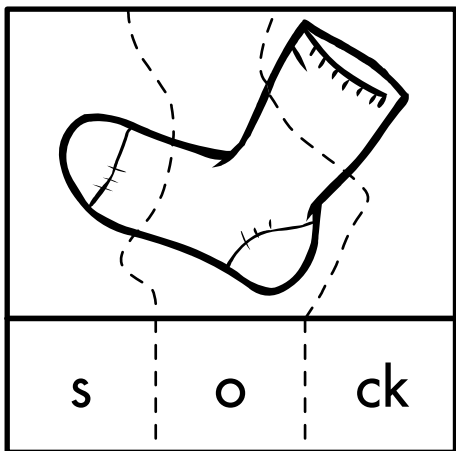



## aeiou

### Naming Capital and Lowercase Letters

**Directions:** Look at the letters. Circle all the lowercase letters.

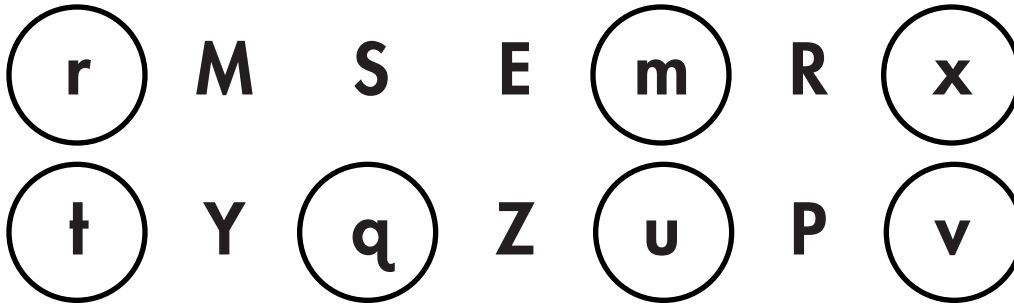

**Directions:** Draw a line to match the pictures that begin with the same sound.

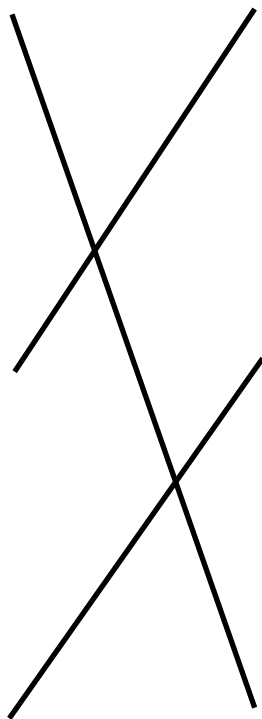
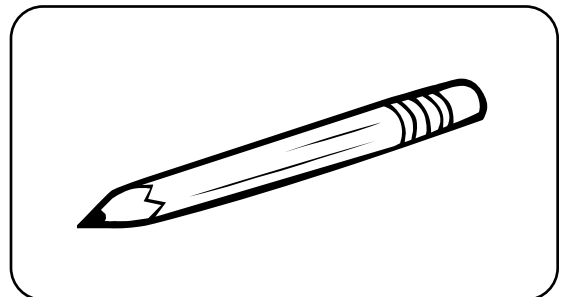
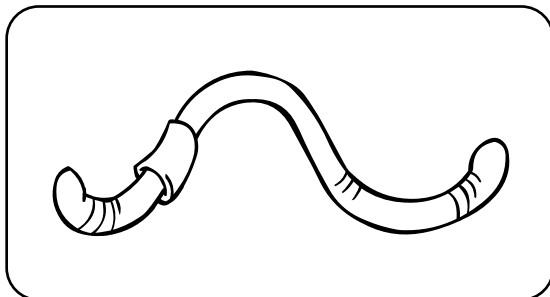
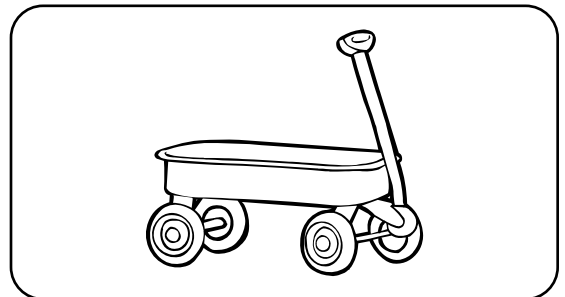
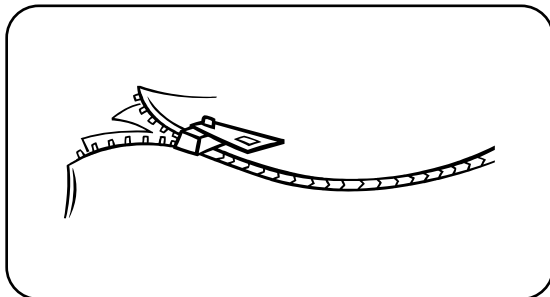
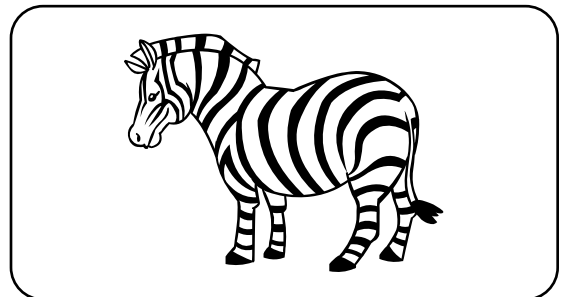
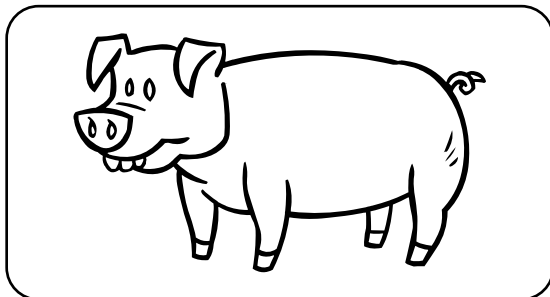

**Directions:** Cut out the puzzles. Say each sound as you build the puzzles. Then read the word aloud.

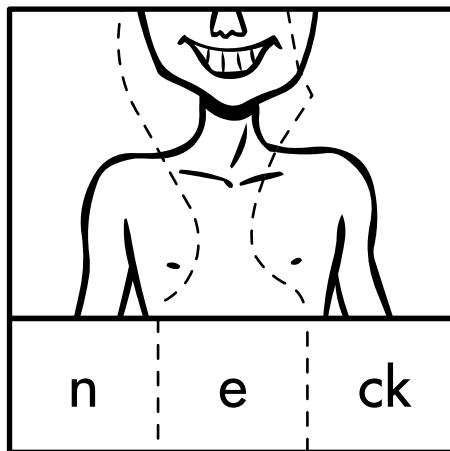
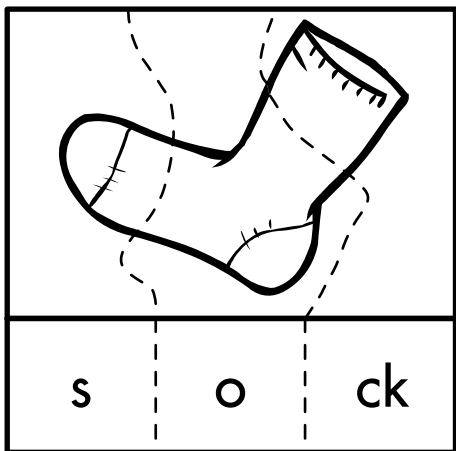

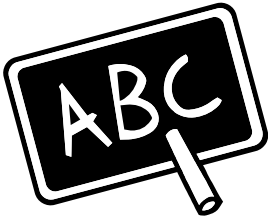

## Answering Questions about Setting

**Directions:** Cut out the pages and put them in order. Staple the pages together. Read the story. Color the pictures. Use the color words to help you.

### What Carlos Sees



by Barbara Davis-Pyles

Name \_\_\_\_\_

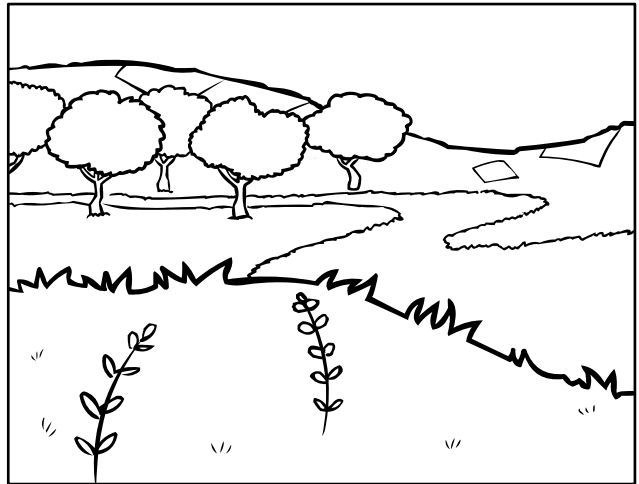

Carlos sees a green field.

1

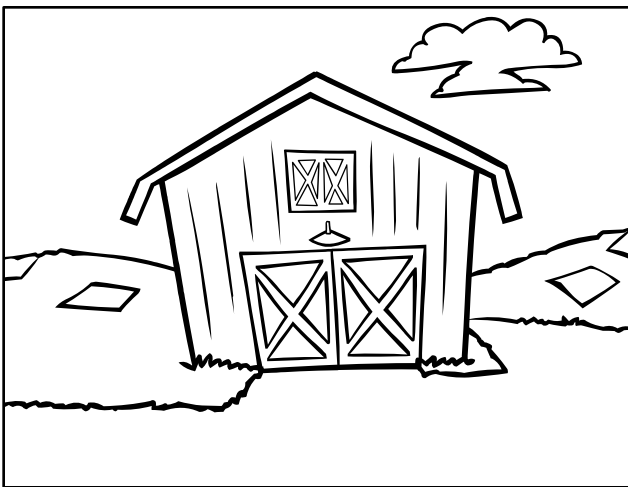

Carlos sees a red barn.

2

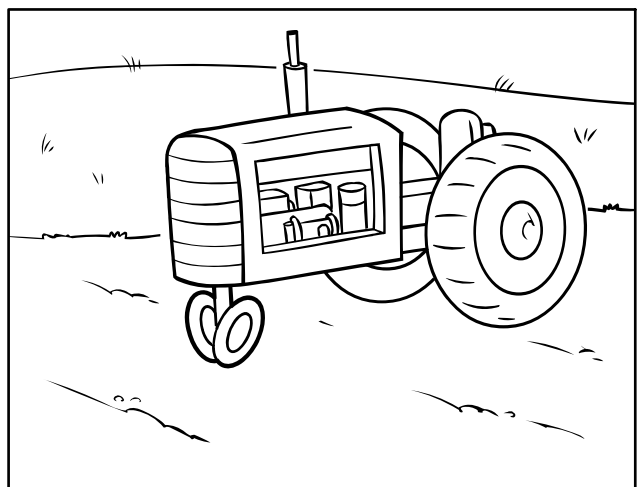

Carlos sees a yellow tractor.

3



Carlos sees an orange house.

4

Where does the story take place?

---

---

---

5

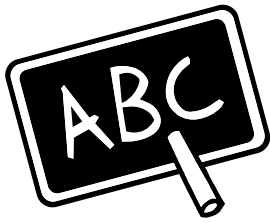

## Answering Questions about Setting

**Directions:** Cut out the pages and put them in order. Staple the pages together. Read the story. Color the pictures. Use the color words to help you.

### What Carlos Sees



by Barbara Davis-Pyles

Name \_\_\_\_\_

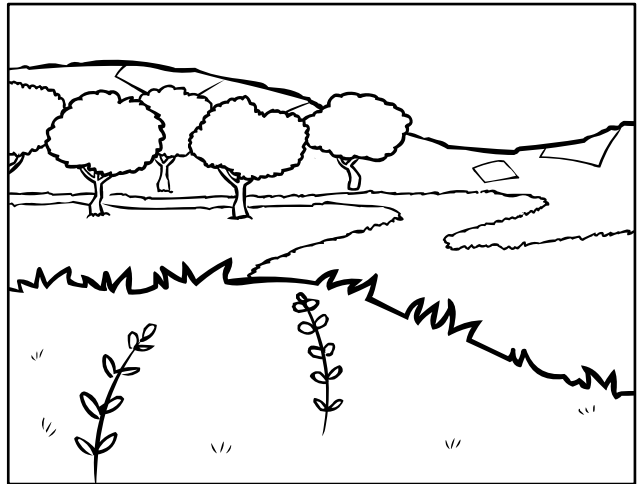

Carlos sees a green field.

1

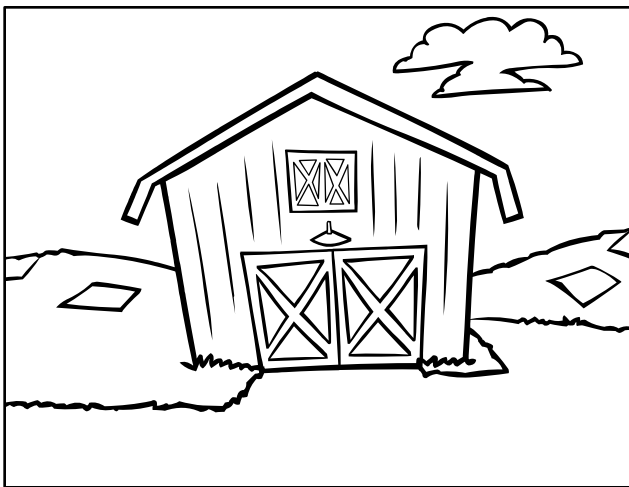

Carlos sees a red barn.

2

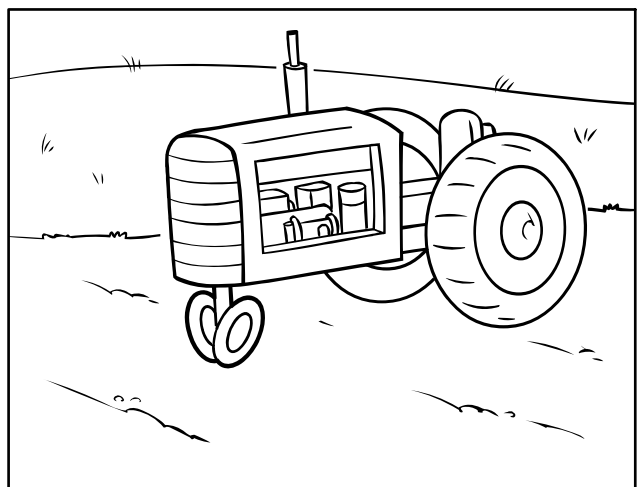

Carlos sees a yellow tractor.

3



Carlos sees an orange house.

4

Where does the story take place?

**Pictures will vary.**

\_\_\_\_\_

-----

**outside**

\_\_\_\_\_

5

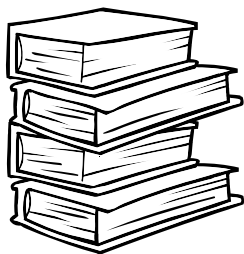

## Understanding Positional Words

**Directions:** Some pictures belong **up** in the sky. Other pictures belong **down** on the grass. Cut and paste the pictures where they belong.

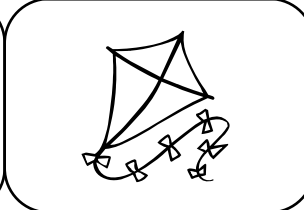
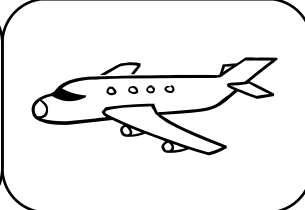
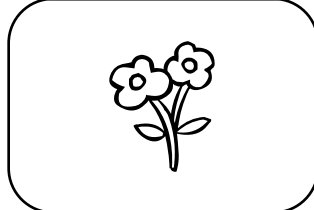
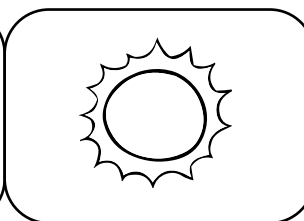
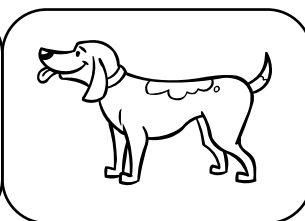
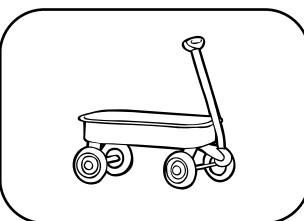
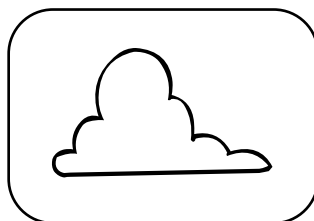
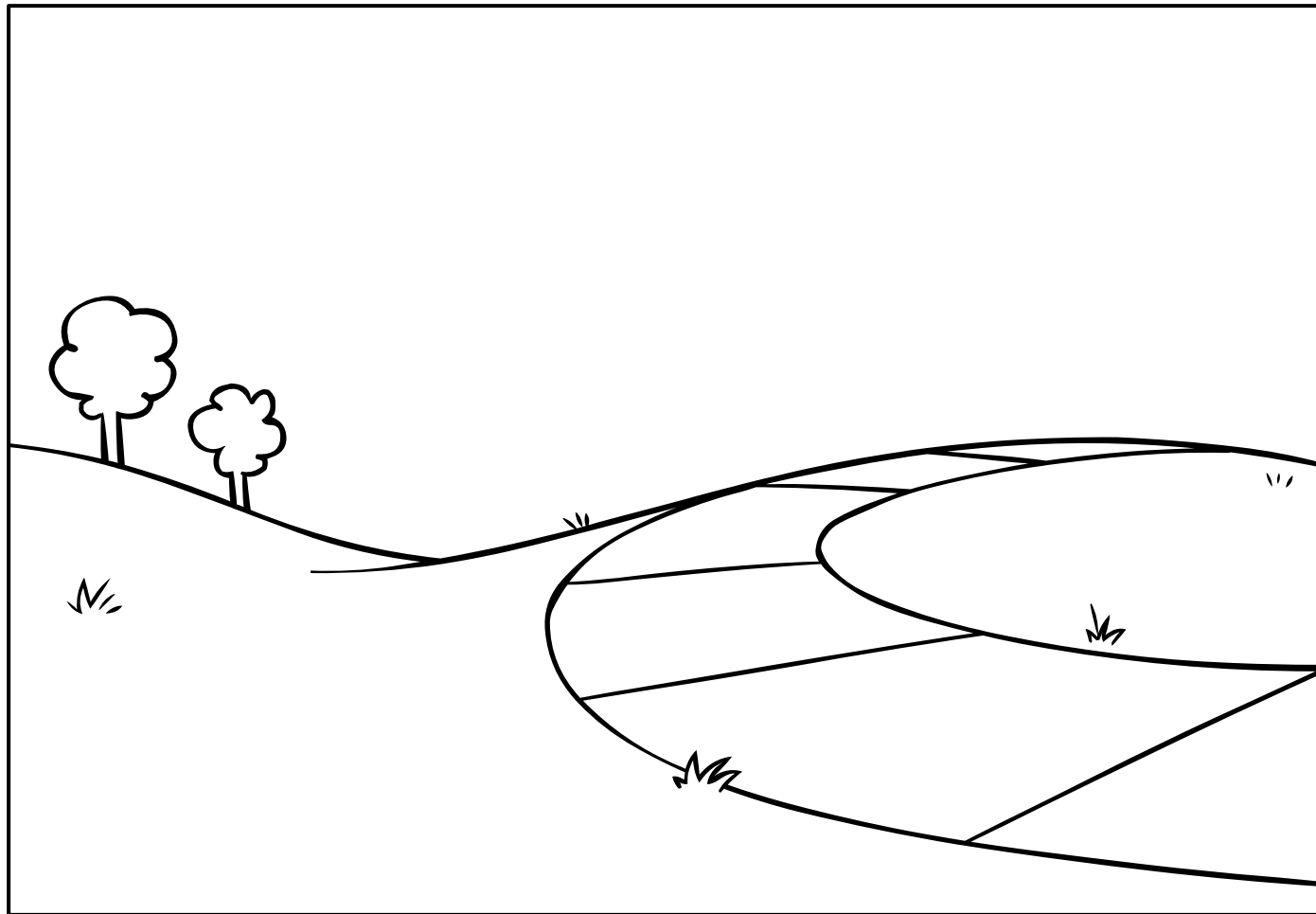

**Directions:** Cut out the pictures. Paste each picture on the shape it matches.

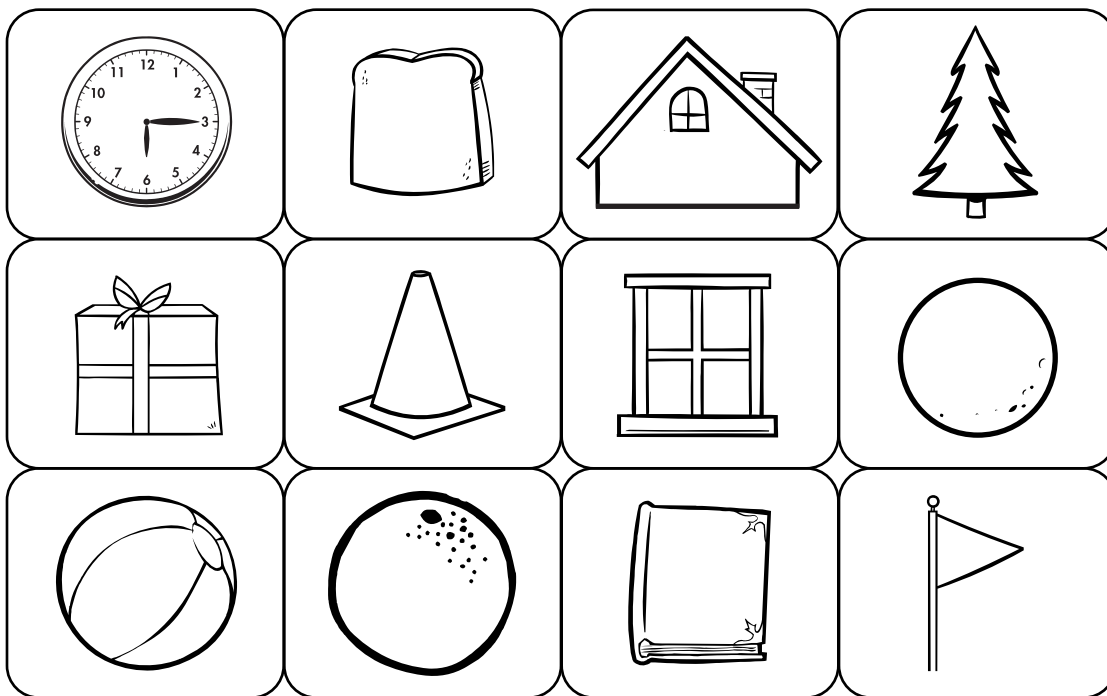
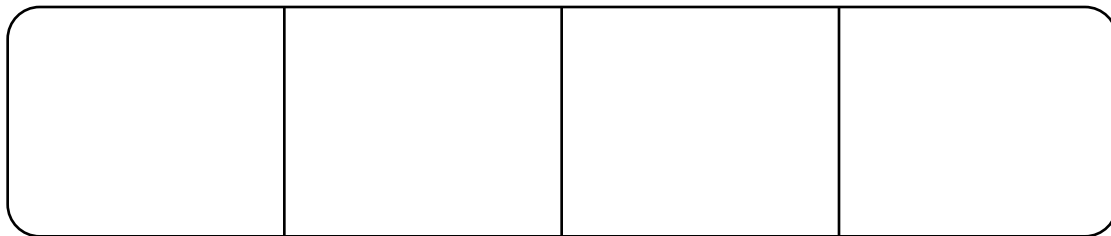
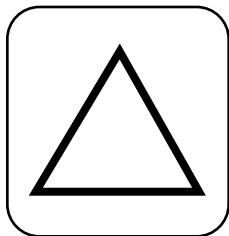
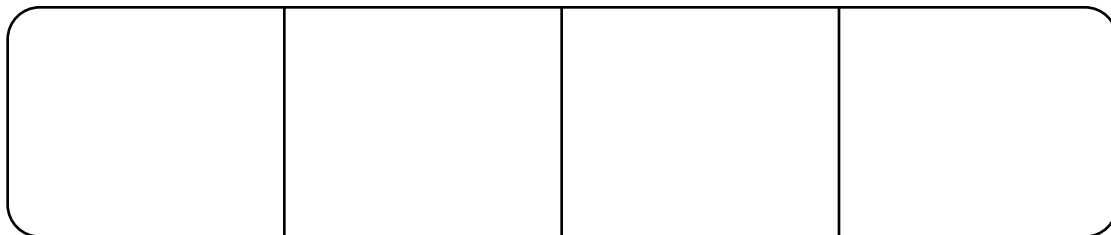
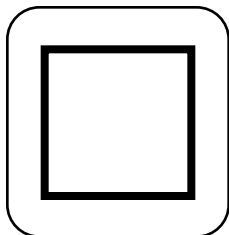
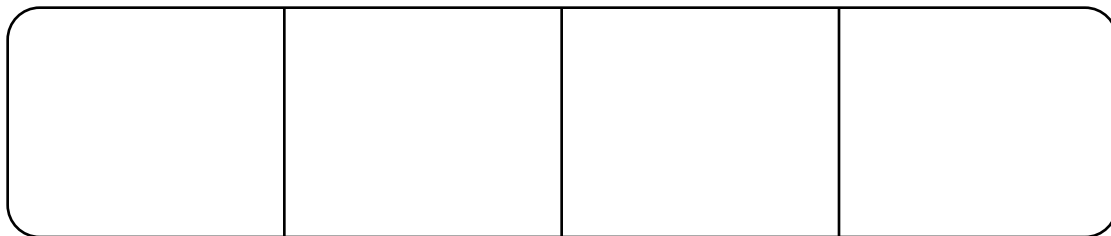
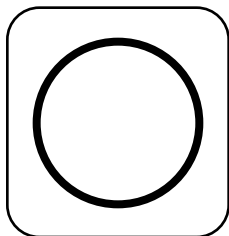



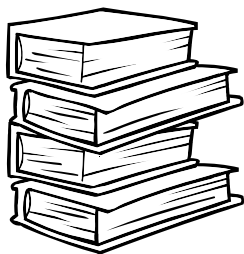

## Understanding Positional Words

**Directions:** Some pictures belong **up** in the sky. Other pictures belong **down** on the grass. Cut and paste the pictures where they belong.

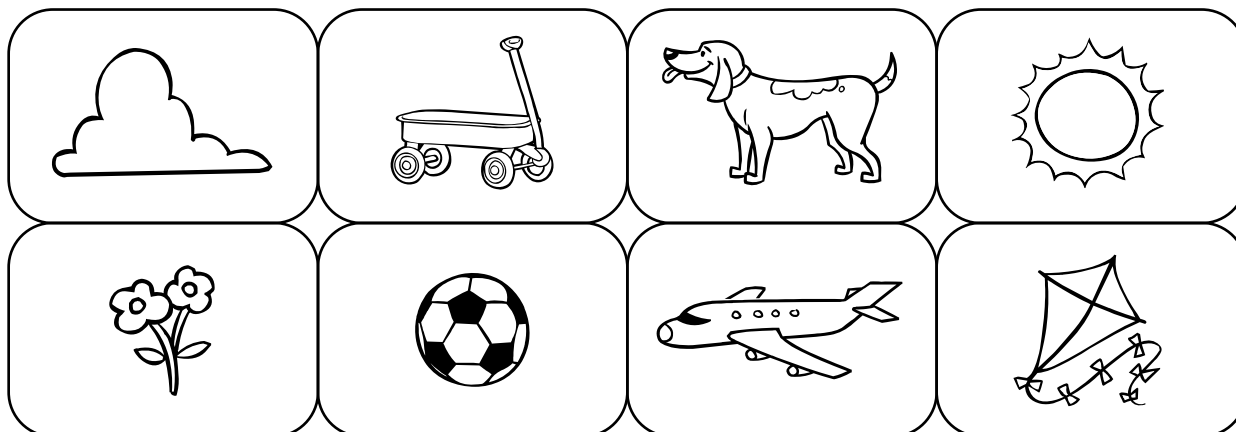
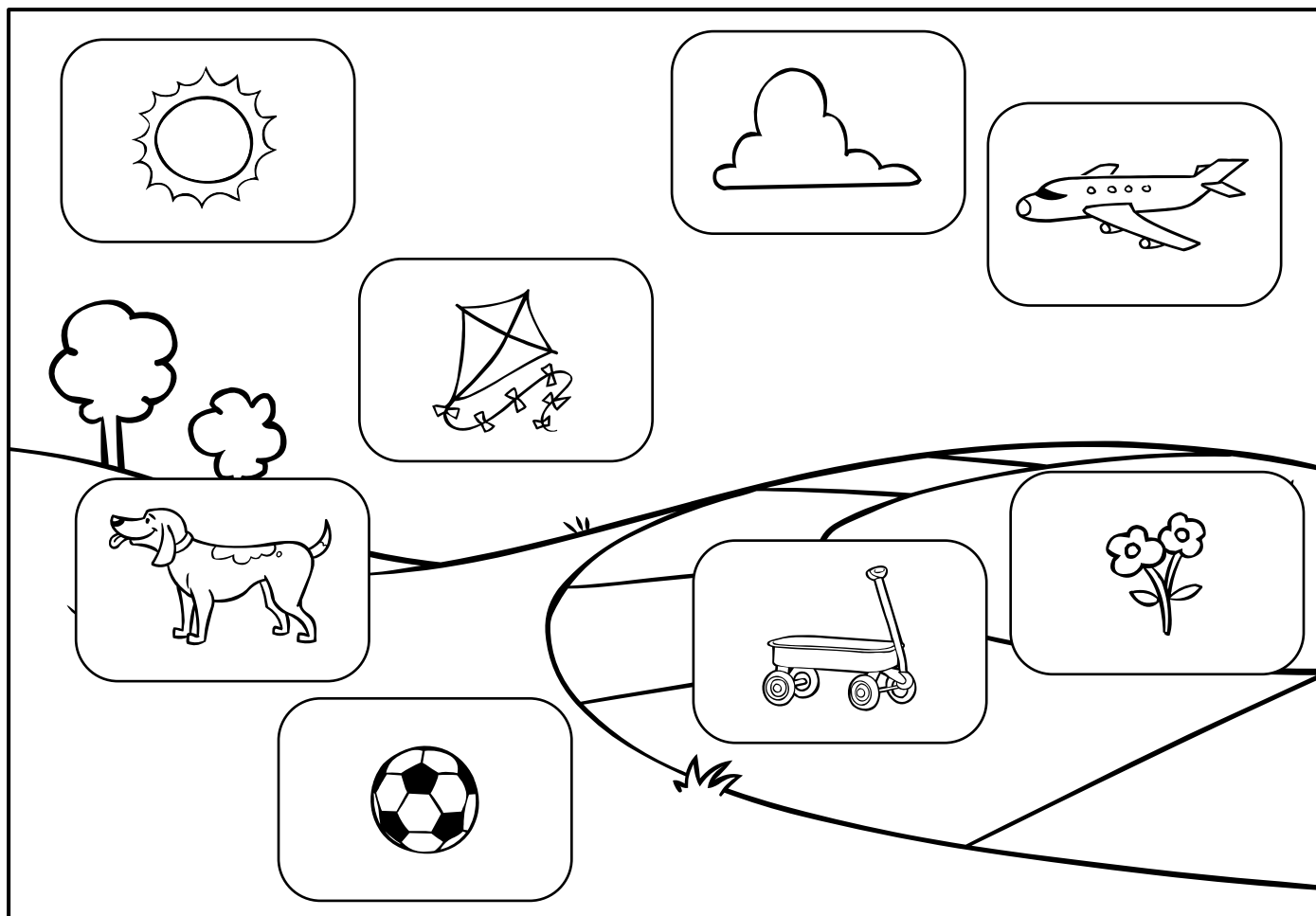

**Directions:** Cut out the pictures. Paste each picture on the shape it matches.

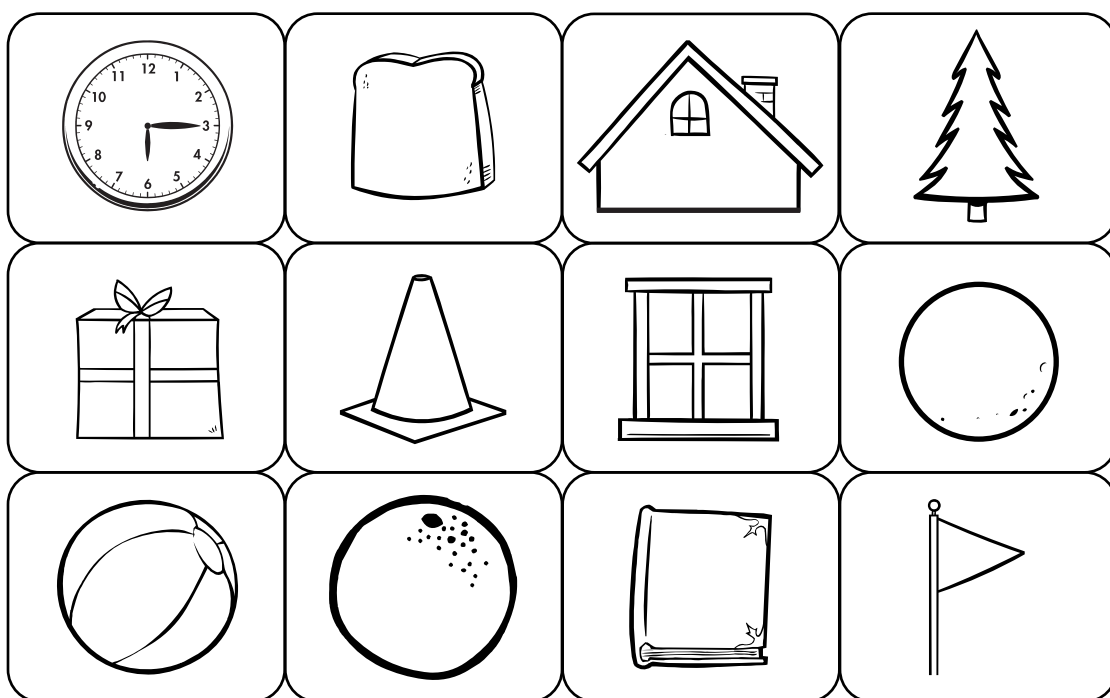
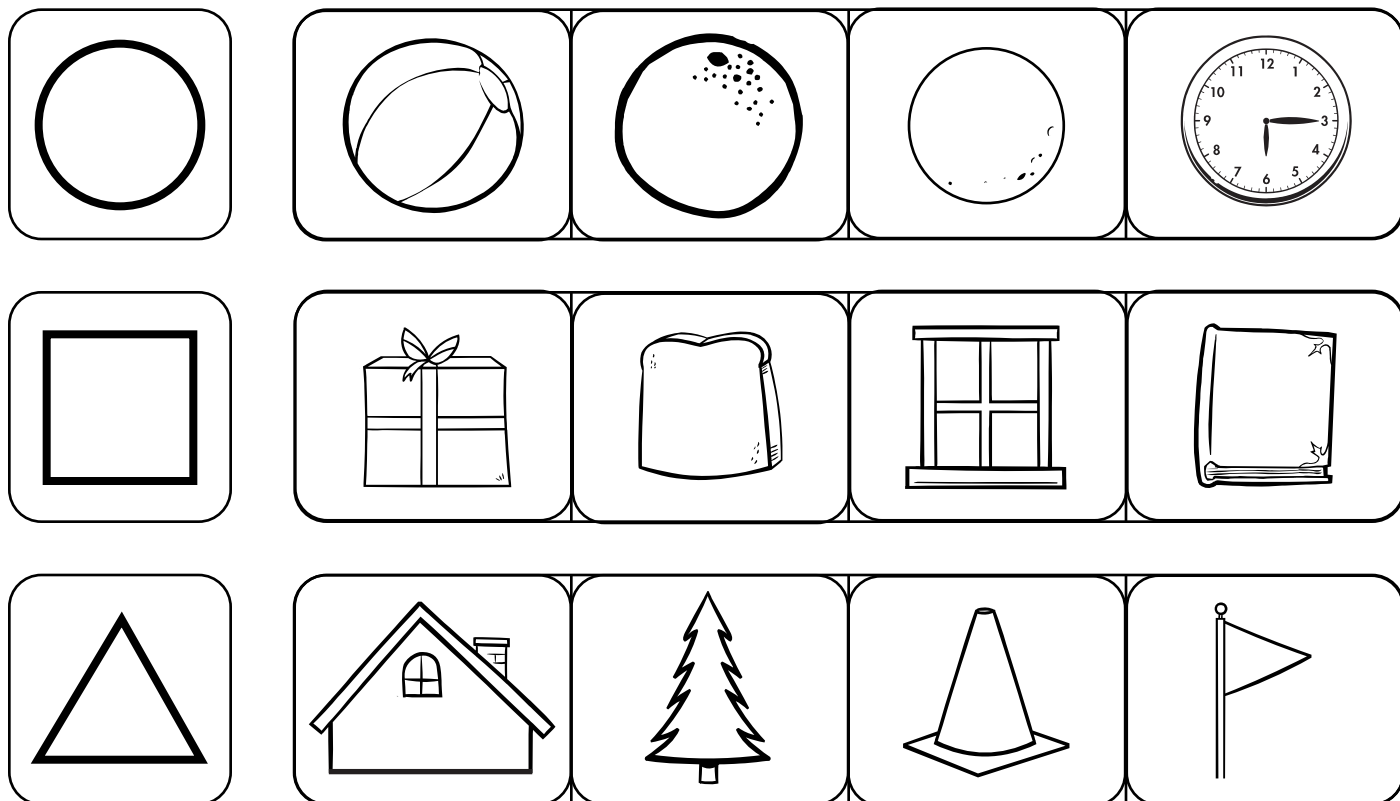

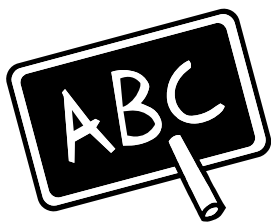

## Identifying Letters of the Alphabet

**Directions:** Cut out the pages and put them in order. Staple the pages together. Draw a picture in each box. Then read the story.

# My Alphabet Poem

Name \_\_\_\_\_

A is for B is for C is for 

D is for



1

E is for F is for 

G is for



2

H is for I is for J is for 

K is for



3

L is for 

M is for 

N is for 

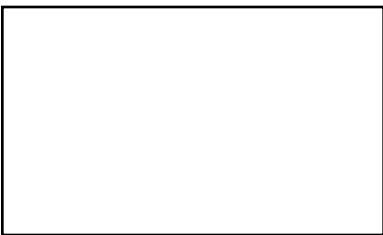
O is for 

4

P is for 

Q is for 

R is for 

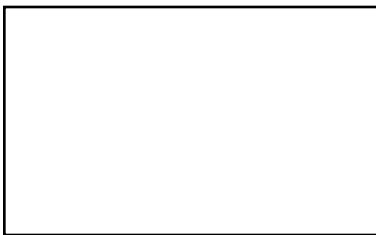
S is for 

5

T is for 

U is for 

V is for 

6

W is for 

X is for 

Y is for 

Z is for 

7

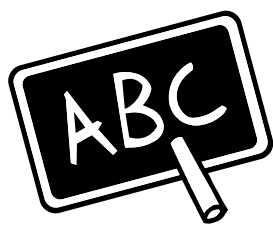

## Identifying Letters of the Alphabet

**Directions:** Cut out the pages and put them in order. Staple the pages together. Draw a picture in each box. Then read the story.

# My Alphabet Poem

Name \_\_\_\_\_

A is for B is for C is for 

D is for



**Pictures  
will vary.**

1

E is for F is for 

G is for



**Pictures  
will vary.**

2

H is for I is for J is for 

K is for



**Pictures  
will vary.**

3

L is for 

M is for 

N is for 

O is for

**Pictures  
will vary.**

4

P is for 

Q is for 

R is for 

S is for

**Pictures  
will vary.**

5

T is for 

U is for 

V is for

**Pictures  
will vary.**

6

W is for 

X is for 

Y is for 

Z is for

**Pictures  
will vary.**

7

## aeiou

### Naming Capital and Lowercase Letters

**Directions:** Fill in the missing letters of the alphabet. Then circle the lowercase letters.

A <b>a</b>	___ b	C ___	___ ___	E ___
___ f	G ___	H ___	___ ___	J ___
___ k	L ___	___ m	___ ___	O ___
___ ___	___ q	R ___	S ___	T ___
U ___	___ v	___ ___	___ x	Y ___
___ z				

**Directions:** Look at the pictures. Say the name of each picture aloud. Then circle the pictures that have the same beginning sound.

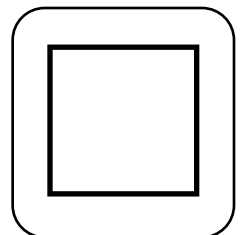
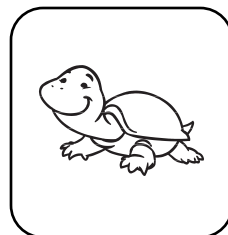
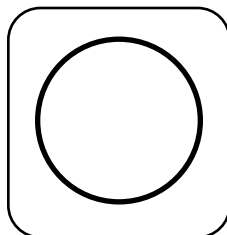
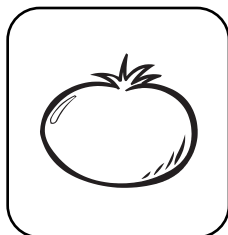
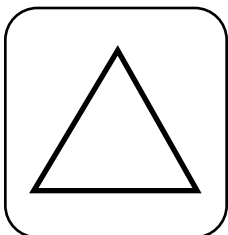

**Directions:** Cut out the puzzles. Say each sound as you build the puzzles. Then read the word aloud.

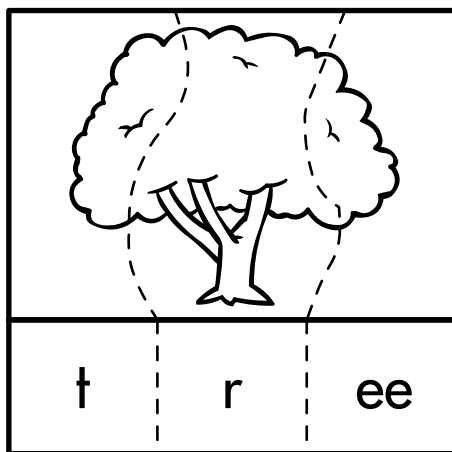
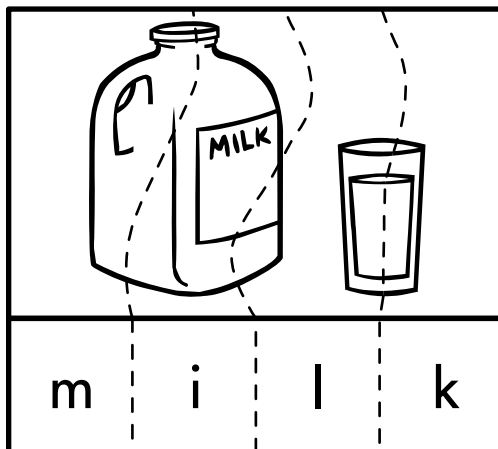



**Directions:** Follow the directions to draw the picture.

1.  a green  .

2.  a yellow  .

3.  a blue   in the  .

4.  green  .

5.  an orange   in the  .

6.  an red   in the  .

7.  yourself.

## aeiou Naming Capital and Lowercase Letters

**Directions:** Fill in the missing letters of the alphabet. Then circle the lowercase letters.

A (a)	B (b)	C (c)	D (d)	E (e)
F (f)	G (g)	H (h)	I (i)	J (j)
K (k)	L (l)	M (m)	N (n)	O (o)
P (p)	Q (q)	R (r)	S (s)	T (t)
U (u)	V (v)	W (w)	X (x)	Y (y)
Z (z)				



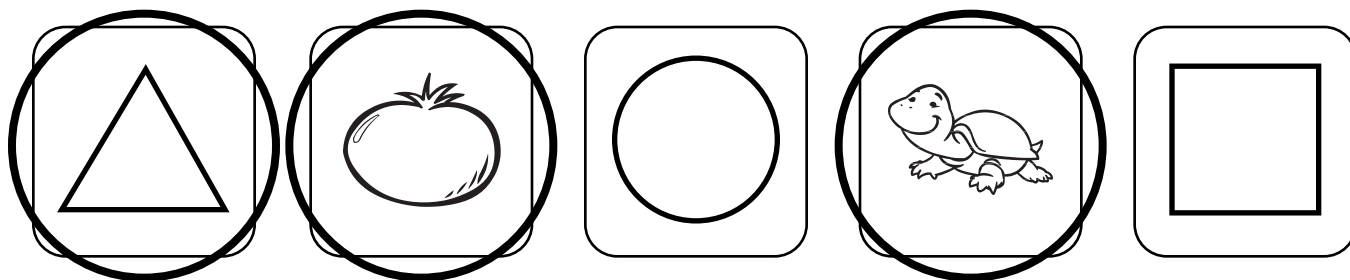



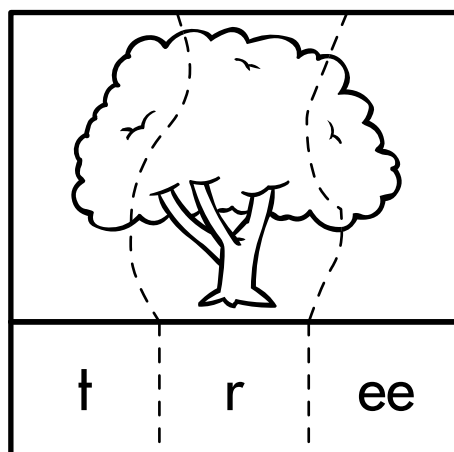
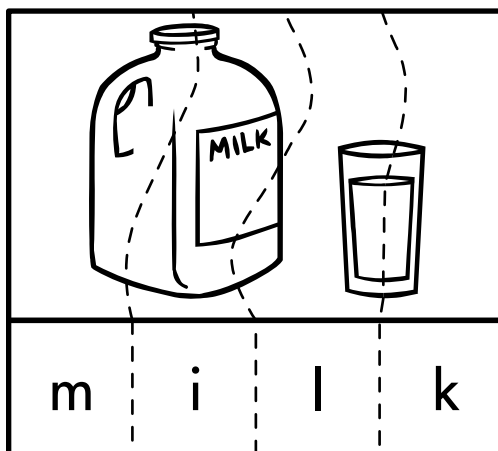











**Directions:** Look at the pictures. Say the name of each picture aloud. Then circle the pictures that have the same beginning sound.



**Directions:** Cut out the puzzles. Say each sound as you build the puzzles. Then read the word aloud.



**Directions:** Follow the directions to draw the picture.

1.  a green  .
2.  a yellow  .
3.  a blue   in the  .
4.  green  .
5.  an orange   in the  .
6.  an red   in the  .
7.  yourself.

**Pictures will vary.**

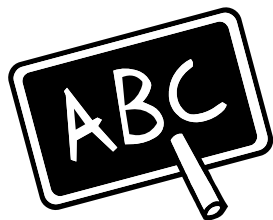

## Identifying Letter Sounds

**Directions:** For each row, say the name of each picture aloud. Then circle the picture that has the same beginning sound as the letter in the box.

S

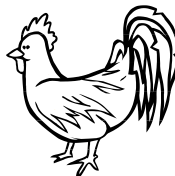
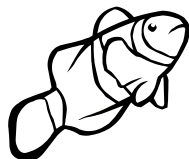

F

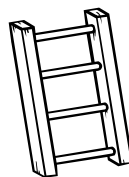

A

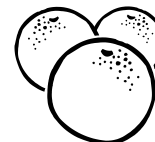
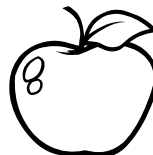

M

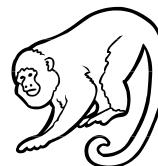

T

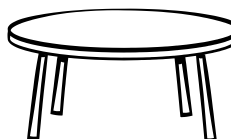

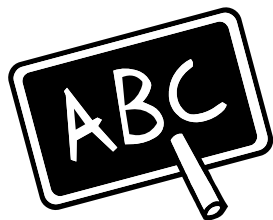

## Identifying Letter Sounds

**Directions:** For each row, say the name of each picture aloud. Then circle the picture that has the same beginning sound as the letter in the box.

S

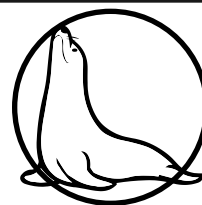
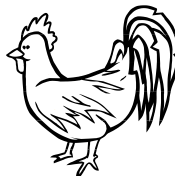
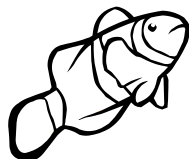

F

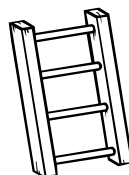
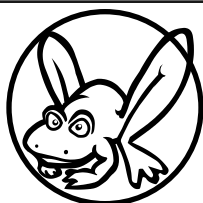

A

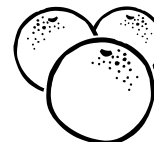
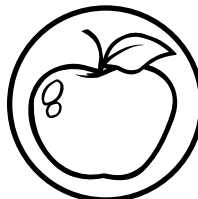

M

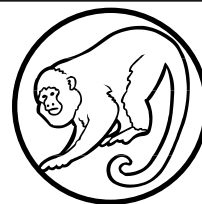
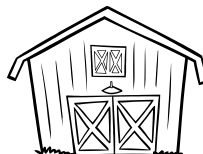

T

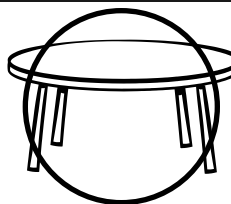

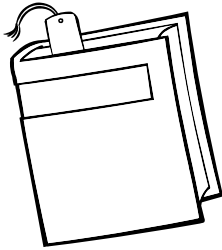

## Answering Questions about Main Characters

**Directions:** Cut out the pages and put them in order. Staple the pages together. Then read the story and answer the question.

### Mayor Mom



by Marianne Lenihan

Name \_\_\_\_\_

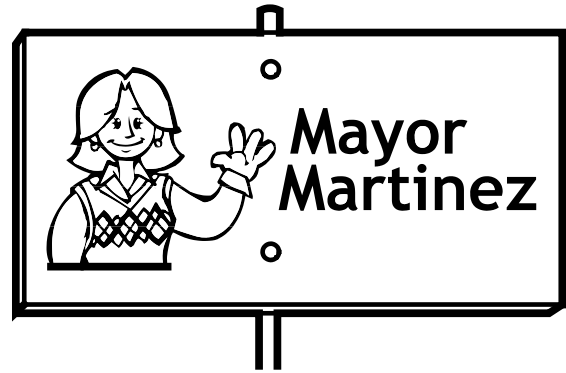

My mom is the mayor.

1



Mom has many meetings.

2



Mom meets about the community center.

3



Mom meets about  
a new playground.

4

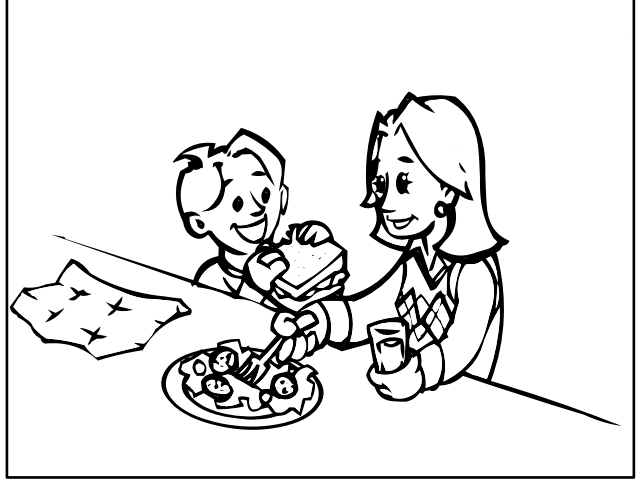

Mom meets me  
for lunch.

5

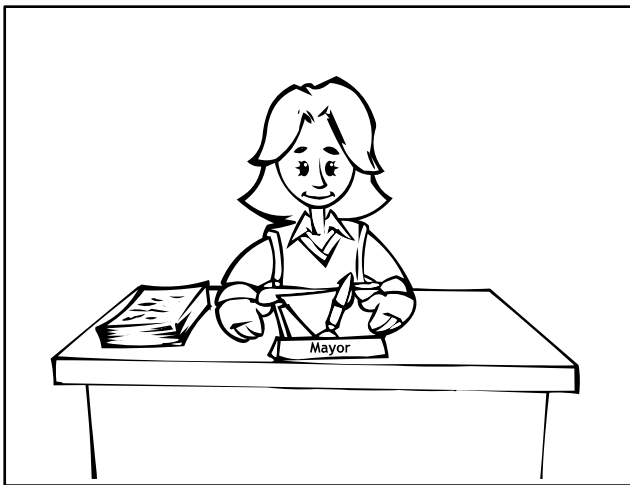

Mom is busy at her job.

6

Who is the character  
in this story?

---

---

---

7



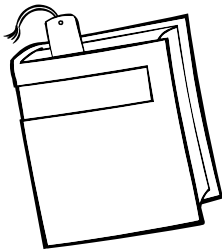

## Answering Questions about Main Characters

**Directions:** Cut out the pages and put them in order. Staple the pages together. Then read the story and answer the question.

### Mayor Mom



by Marianne Lenihan

Name \_\_\_\_\_

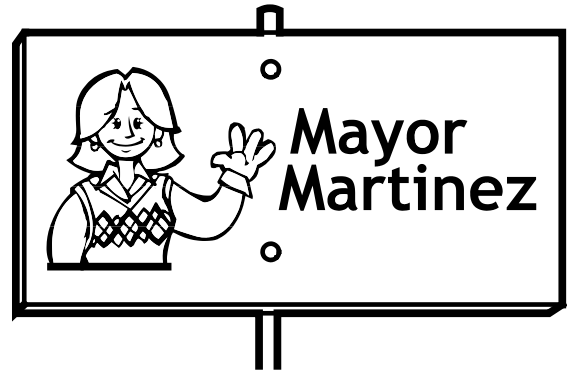

My mom is the mayor.

1



Mom has many meetings.

2



Mom meets about the community center.

3



Mom meets about  
a new playground.

4

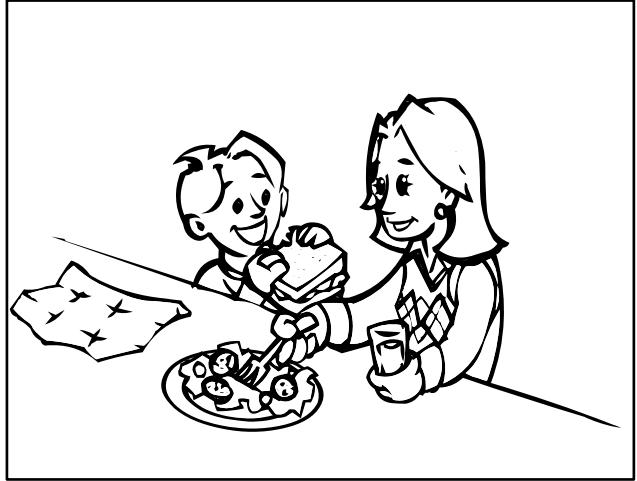

Mom meets me  
for lunch.

5



Mom is busy at her job.

6

Who is the character  
in this story?

**Pictures  
will vary.**

---

**the māyōr, my mōm**

7

## aeiou Understanding Positional Words

**Directions:** Follow the directions to draw the picture.

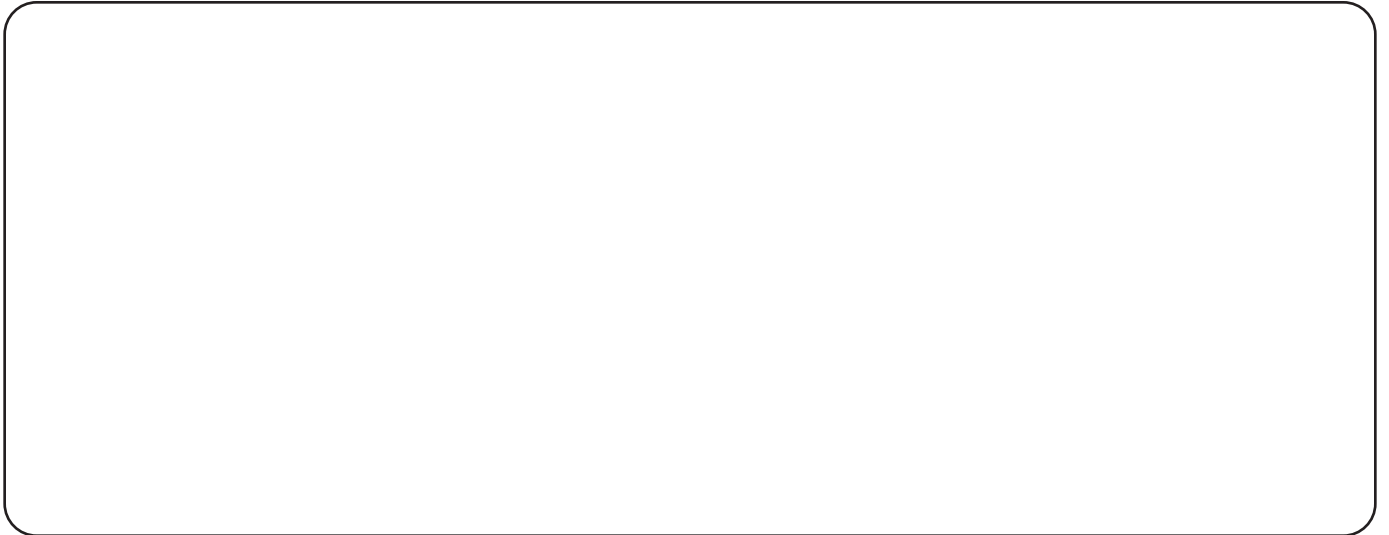

1.  a  flying  a .

2.  a  walking  a .

3.  a  walking  a hill.

4.  a  walking  a hill.



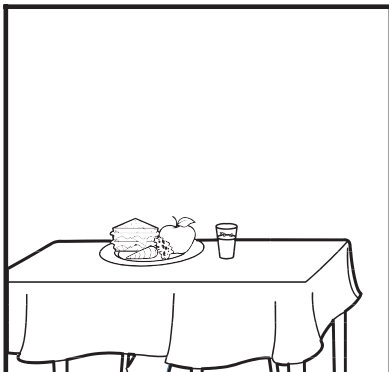

**Directions:** Circle the lunch **before** it is eaten. Draw an X on the lunch **after** it is eaten.

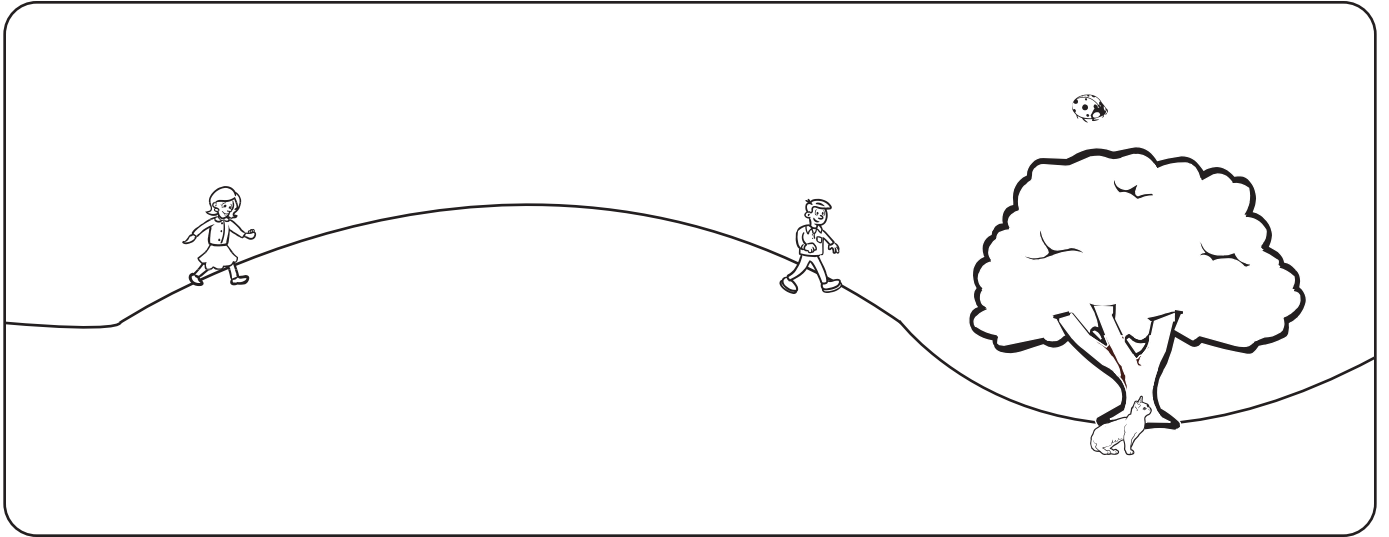

## aeiou Understanding Positional Words

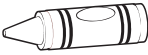
**Directions:** Follow the directions to draw the picture.

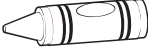
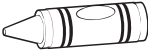

1.  a  flying  a .
2.  a  walking  a .
3.  a  walking  a hill.
4.  a  walking  a hill.

**Directions:** Circle the lunch **before** it is eaten. Draw an X on the lunch **after** it is eaten.

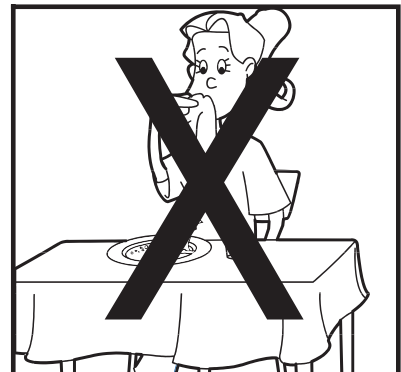
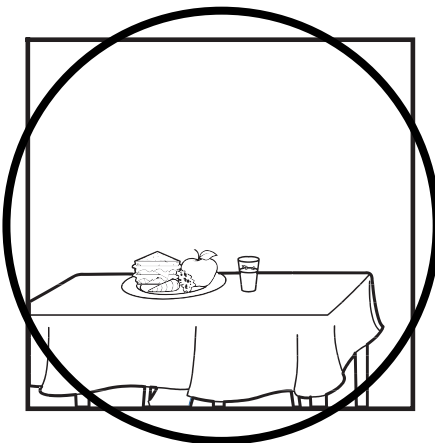

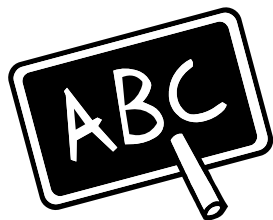

## Segmenting Words

**Directions:** Cut out the puzzles. Say each sound as you build the puzzle. Then read the word aloud.

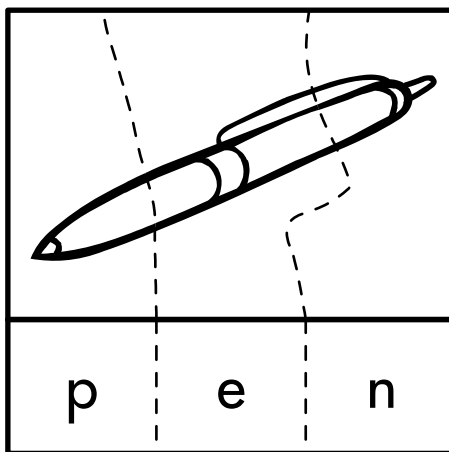
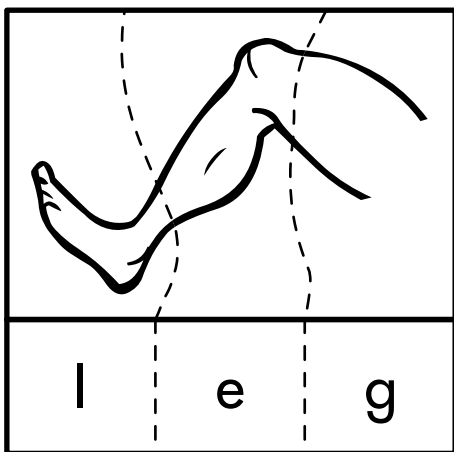
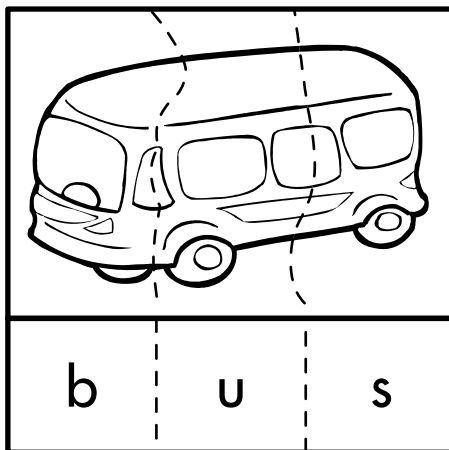
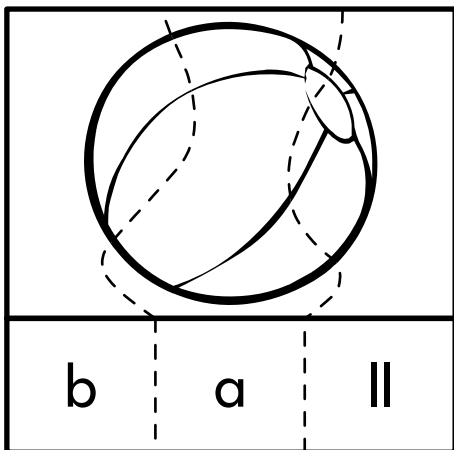

**Directions:** Cut out the pictures. Sort them into groups. Then paste each group in a box.

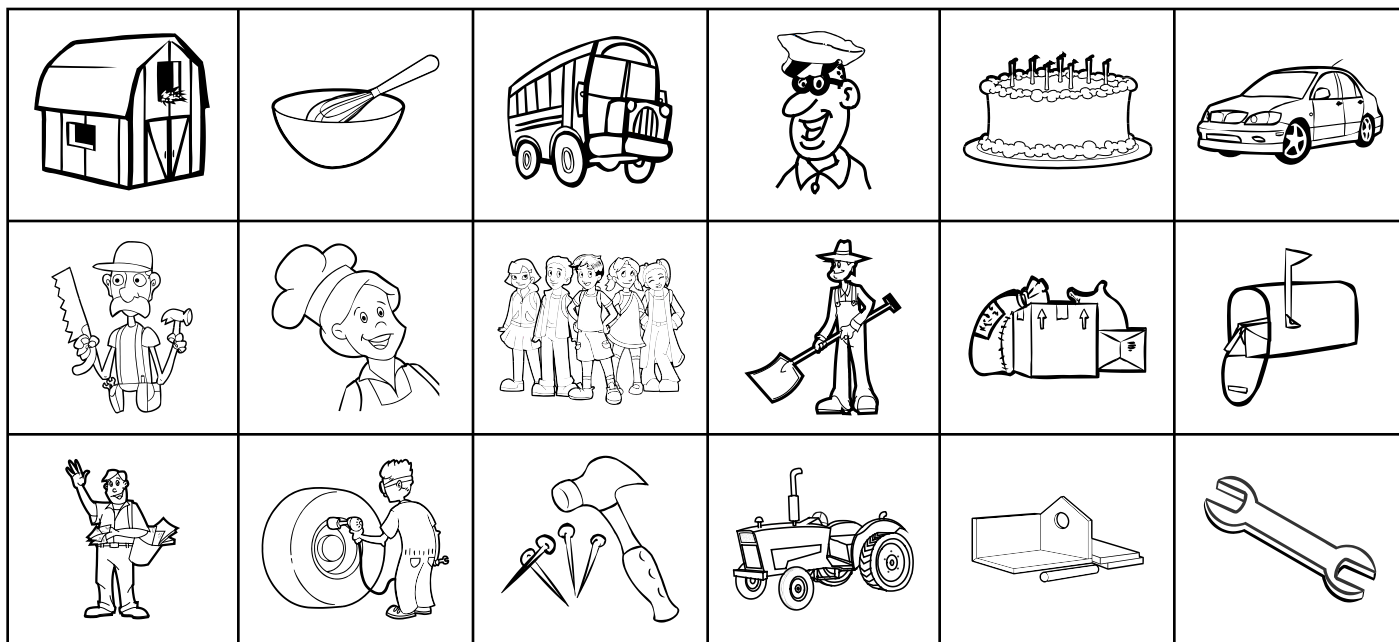

--	--	--

--	--	--

--	--	--

--	--	--

--	--	--

--	--	--

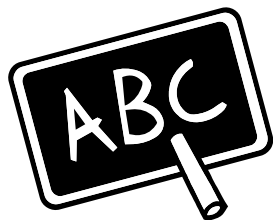

## Segmenting Words

**Directions:** Cut out the puzzles. Say each sound as you build the puzzle. Then read the word aloud.

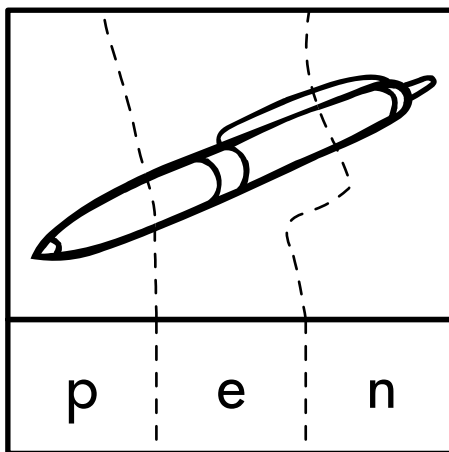
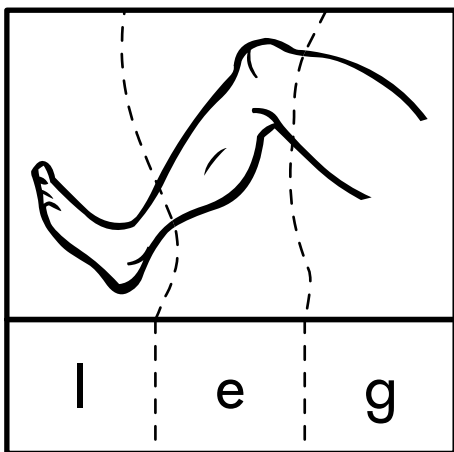
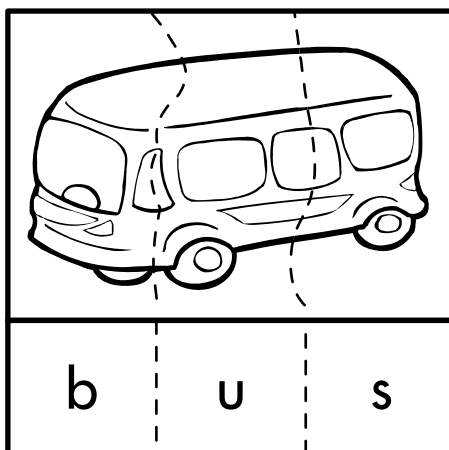
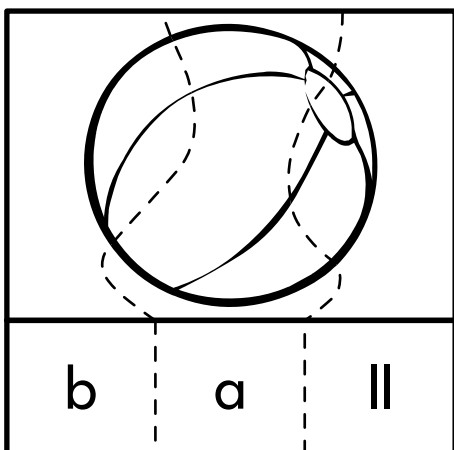



**Directions:** Cut out the pictures. Sort them into groups. Then paste each group in a box.

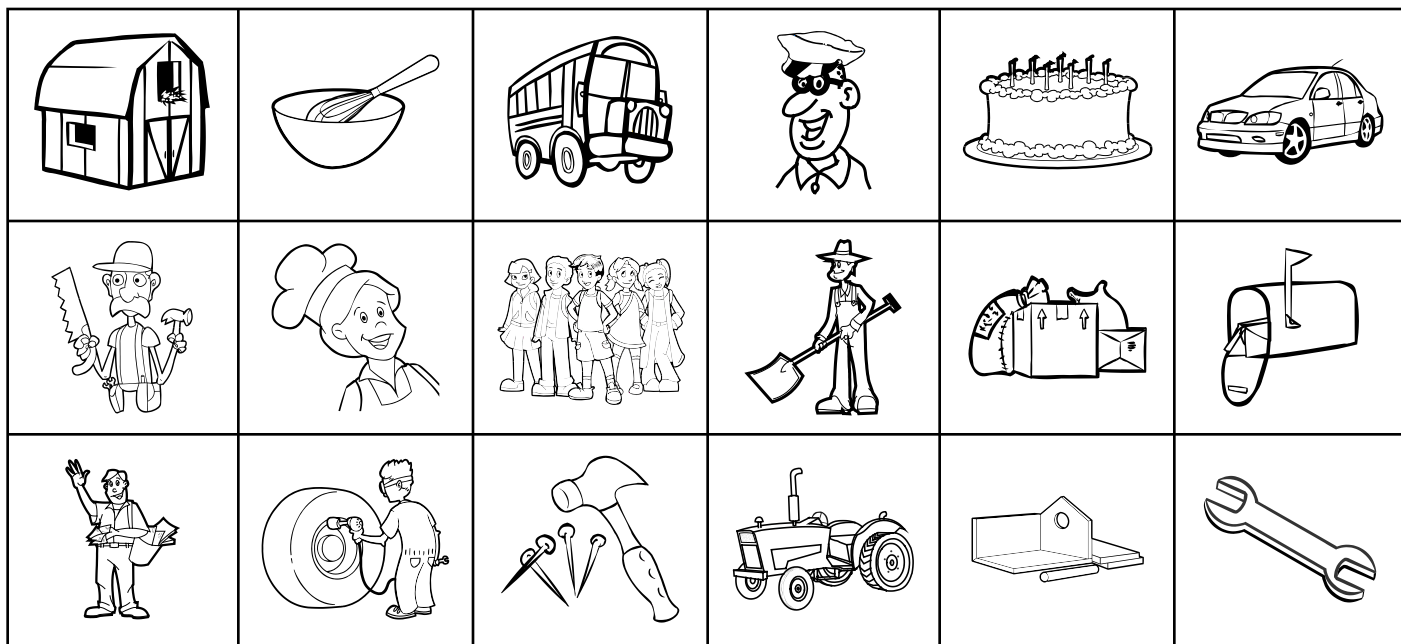

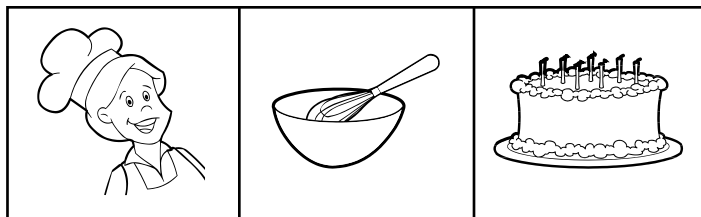
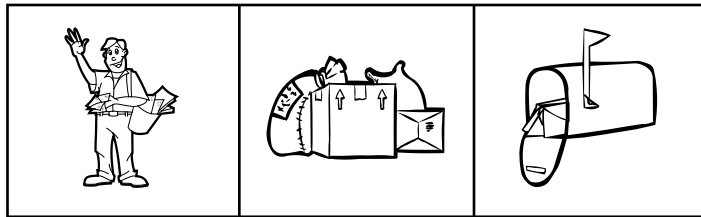
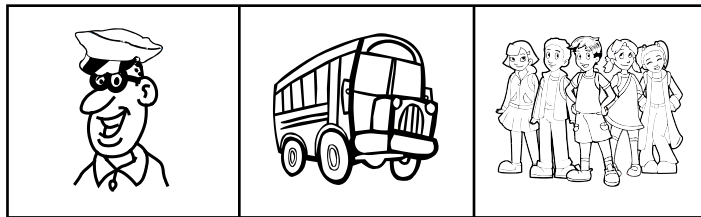
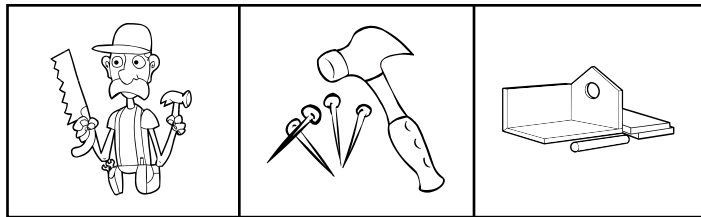
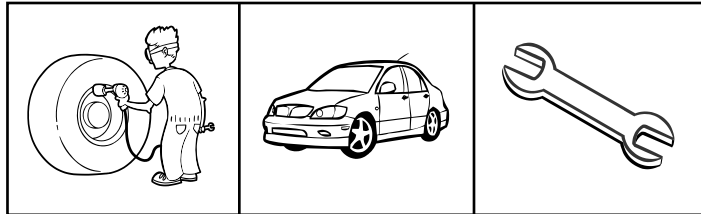
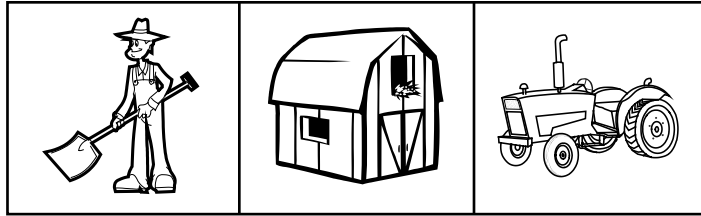

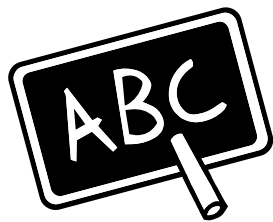

## Identifying Ending Sounds

**Directions:** For each row, say the name of each picture aloud. Then circle the pictures that have the same ending sounds.

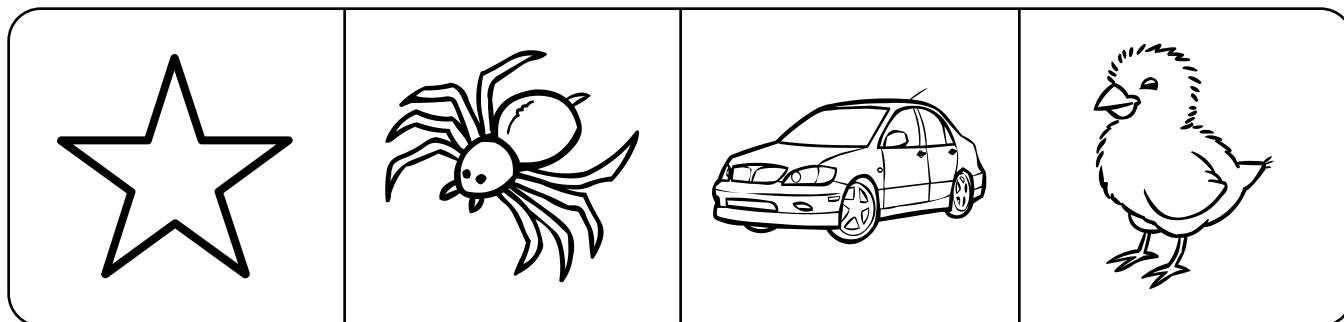
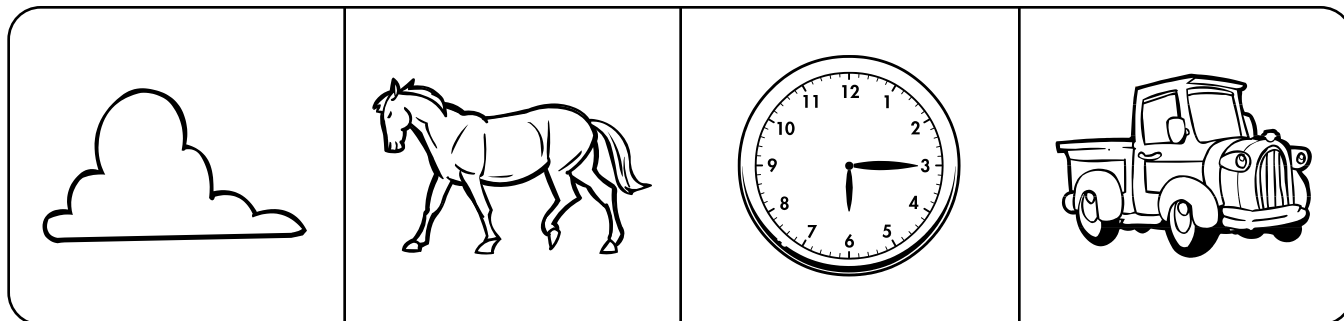
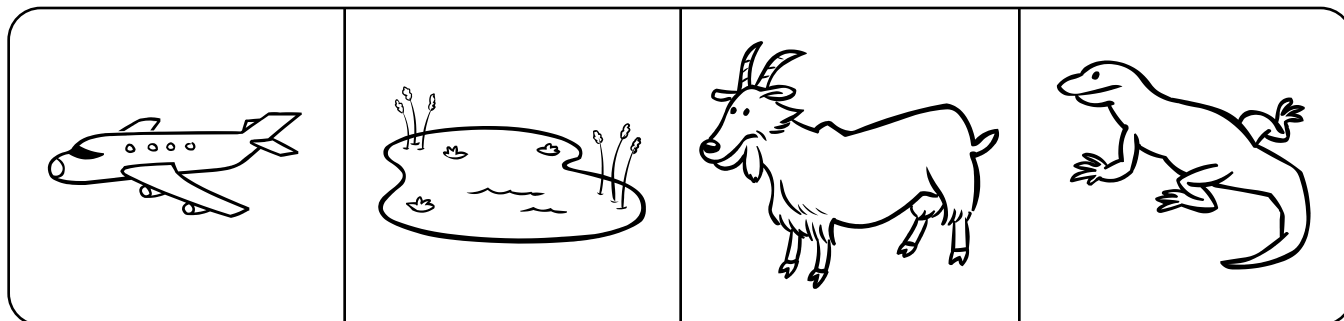
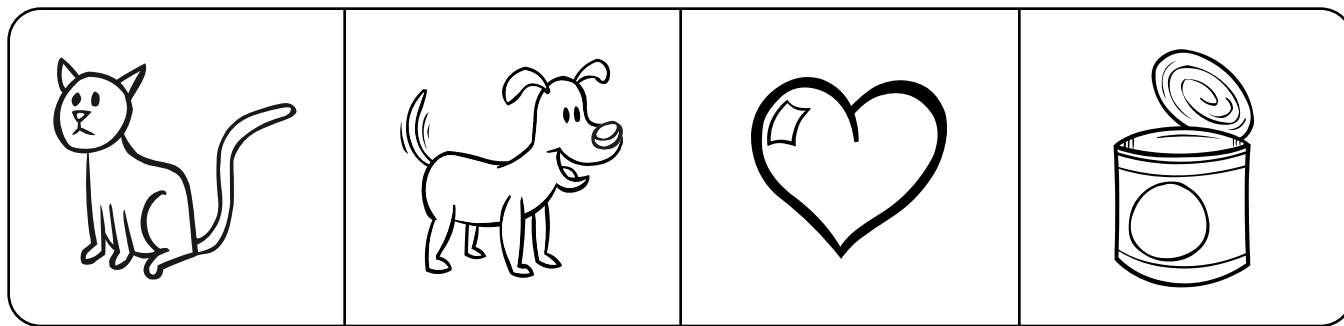

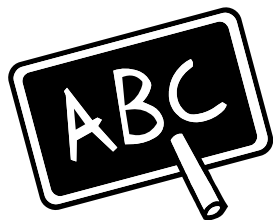

## Identifying Ending Sounds

**Directions:** For each row, say the name of each picture aloud. Then circle the pictures that have the same ending sounds.

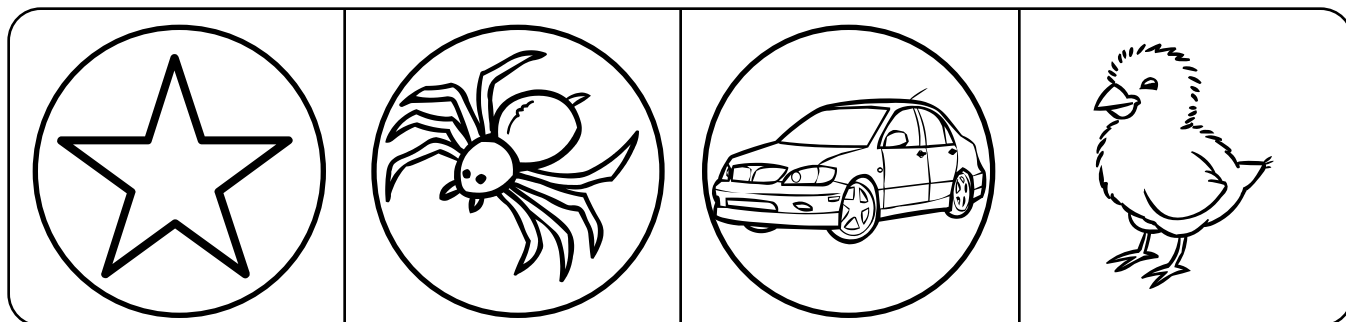
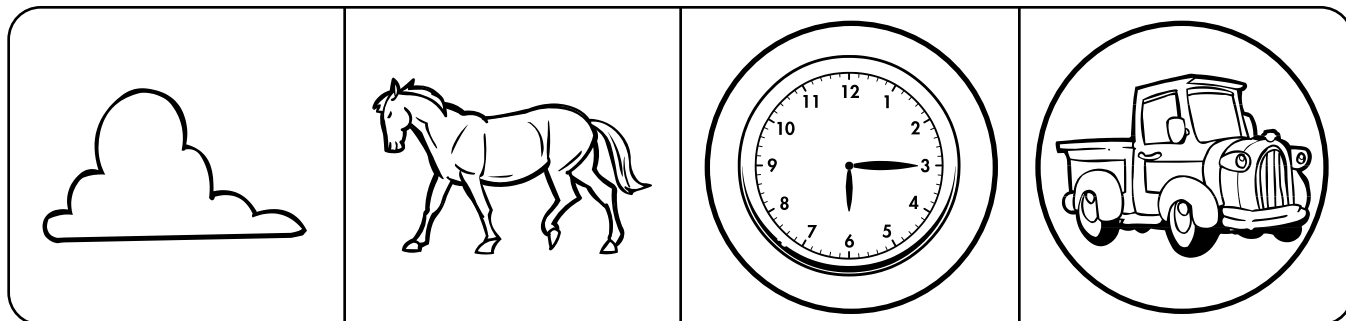
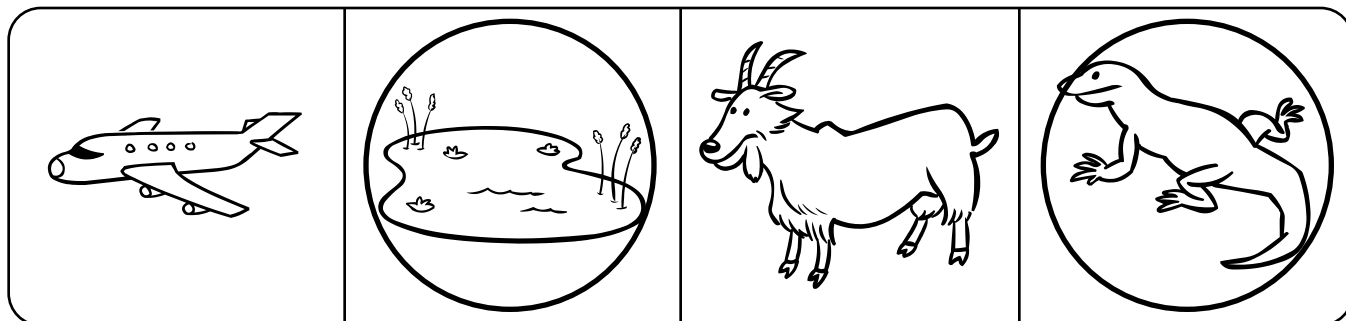
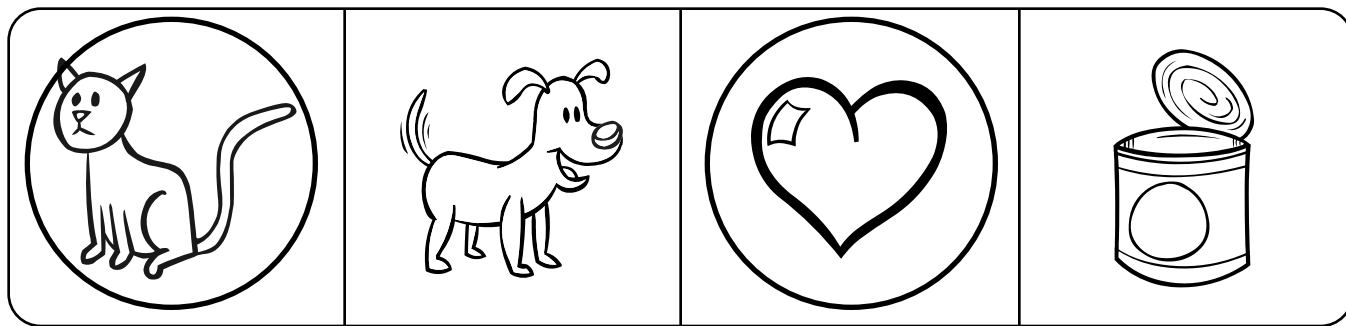

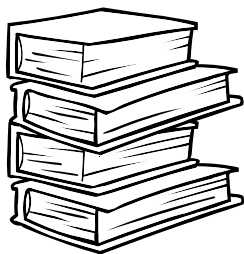

## Identifying Sound-Letter Associations

**Directions:** Say the name of each picture aloud. Then circle the picture that has the same beginning sound as the letter in the box.

M

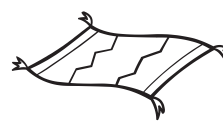
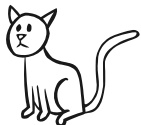

**Directions:** Say the name of each picture aloud. Then circle the pictures that have the same ending sounds.

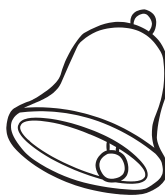

**Directions:** Circle the bird flying **over** the water. Draw an X on the fish swimming **under** the water.

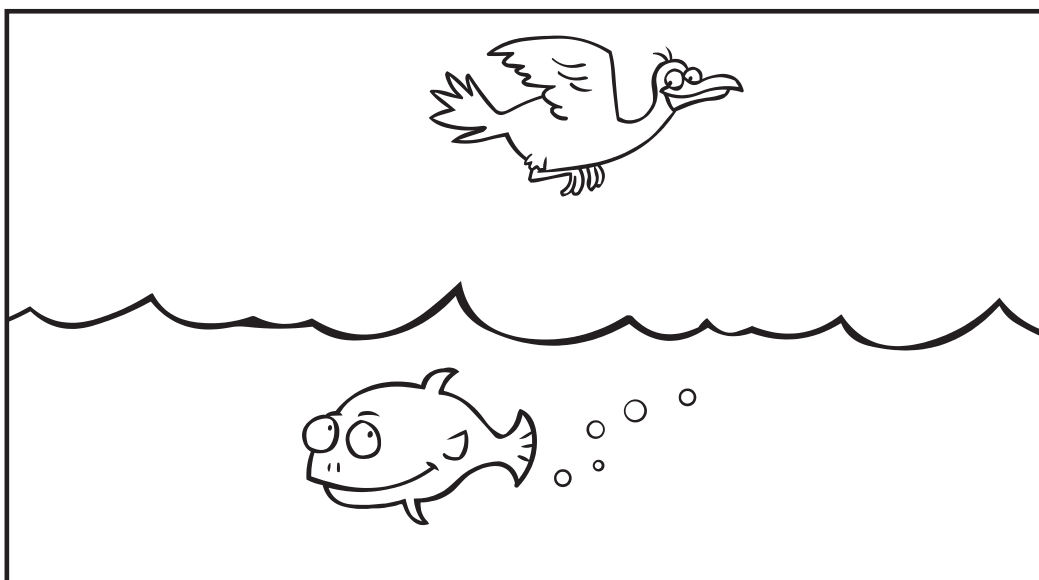

**Directions:** Cut out the puzzle. Say each sound as you build the puzzle. Then read the word aloud.

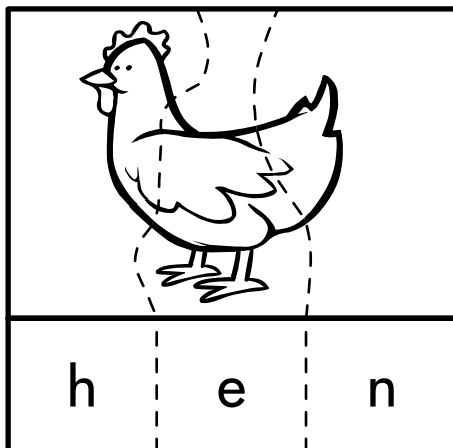

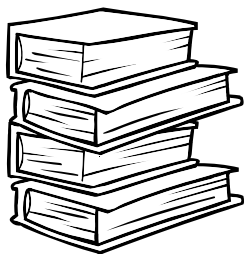

## Identifying Sound-Letter Associations

**Directions:** Say the name of each picture aloud. Then circle the picture that has the same beginning sound as the letter in the box.

M

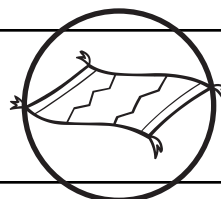

**Directions:** Say the name of each picture aloud. Then circle the pictures that have the same ending sounds.

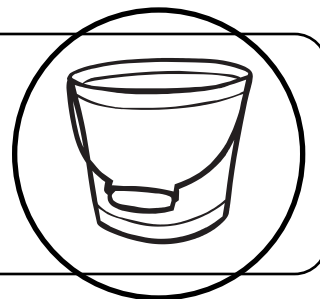
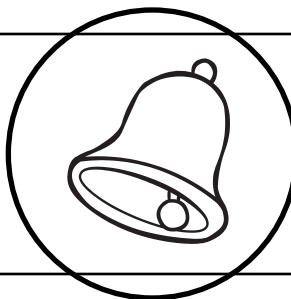
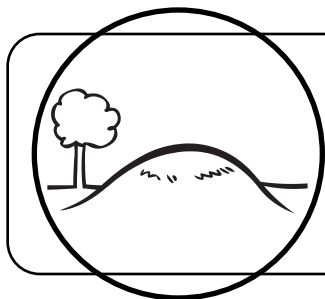

**Directions:** Circle the bird flying **over** the water. Draw an X on the fish swimming **under** the water.

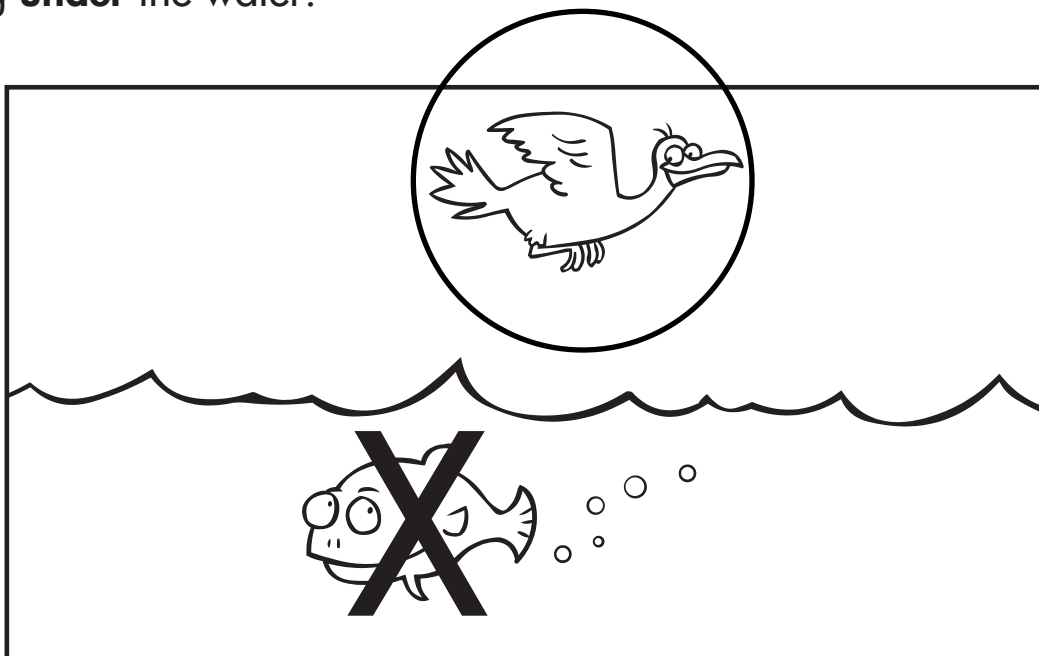

**Directions:** Cut out the puzzle. Say each sound as you build the puzzle. Then read the word aloud.

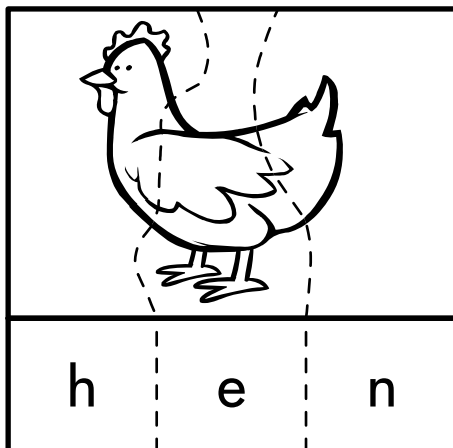



## aeiou Identifying Sound-Letter Associations

**Directions:** Look at the pictures. Say the name of each picture aloud. Then write the missing letter.

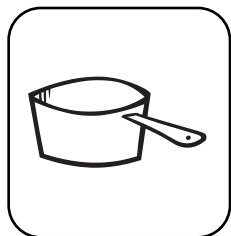

\_\_\_ o t



t \_\_\_ p

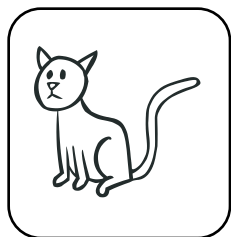

\_\_\_ a t



c a \_\_\_



m a \_\_\_



\_\_\_ a t

**Directions:** Cut out the pictures. Sort them into groups. Then paste the pictures on the correct drawing.

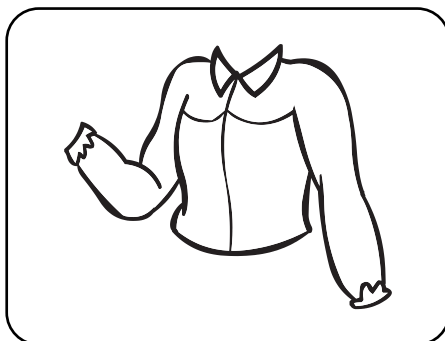
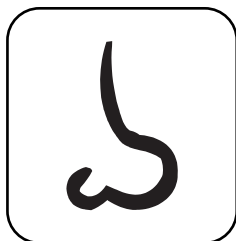
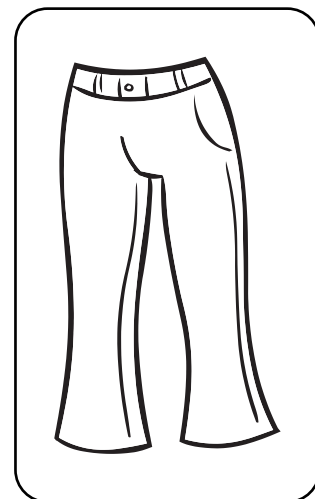
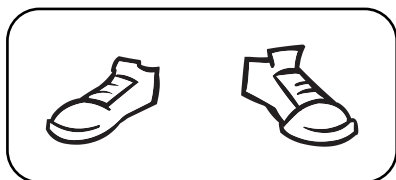

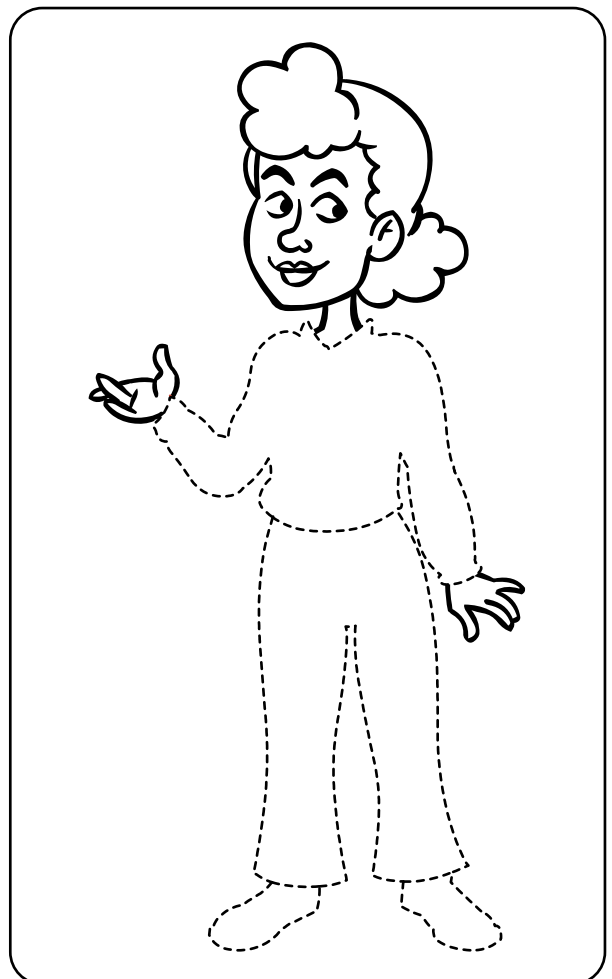

## aeiou Identifying Sound-Letter Associations

**Directions:** Look at the pictures. Say the name of each picture aloud. Then write the missing letter.

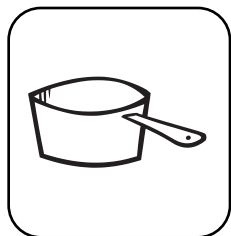

p o t



t o p

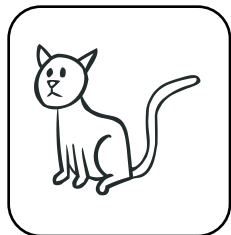

c a t



c a n



m a p



r a t

**Directions:** Cut out the pictures. Sort them into groups. Then paste the pictures on the correct drawing.

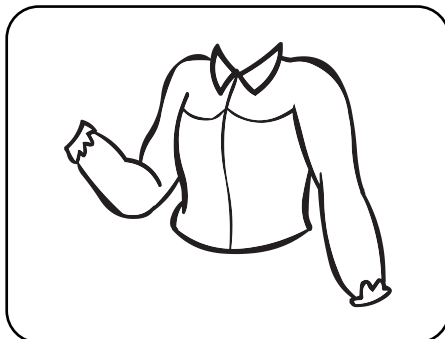
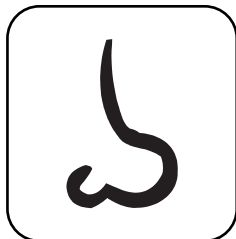
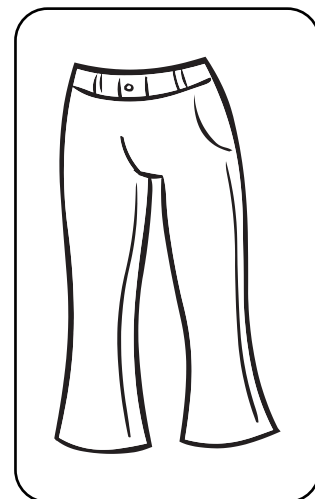
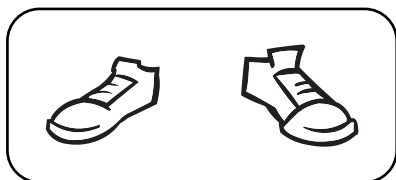

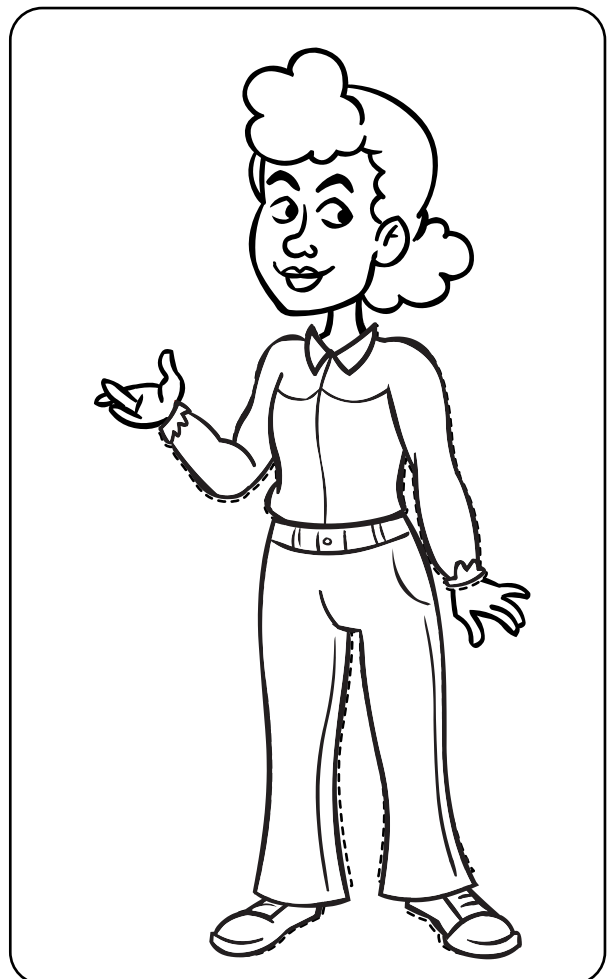

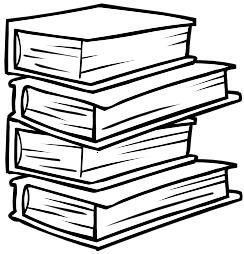

## Identifying Pictures with the Same Medial Sounds

**Directions:** Look at the pictures. Say the name of each picture aloud. Then circle the pictures that have a short /ă/ sound.

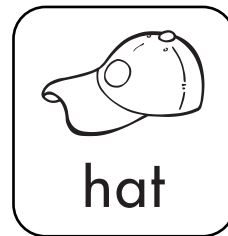
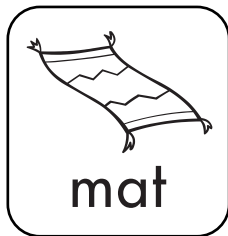
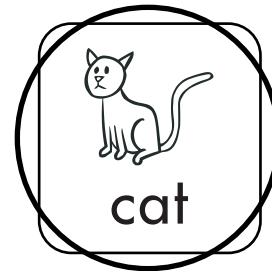
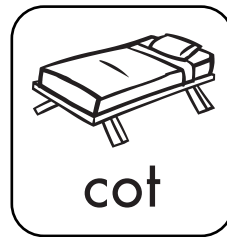
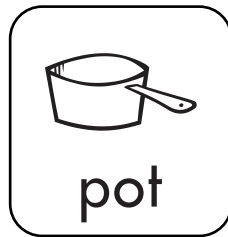
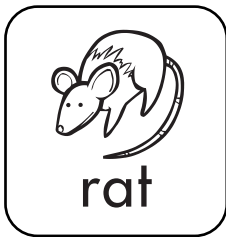

**Directions:** Cut out each picture. Match each picture to a season. Then paste the pictures in the boxes.

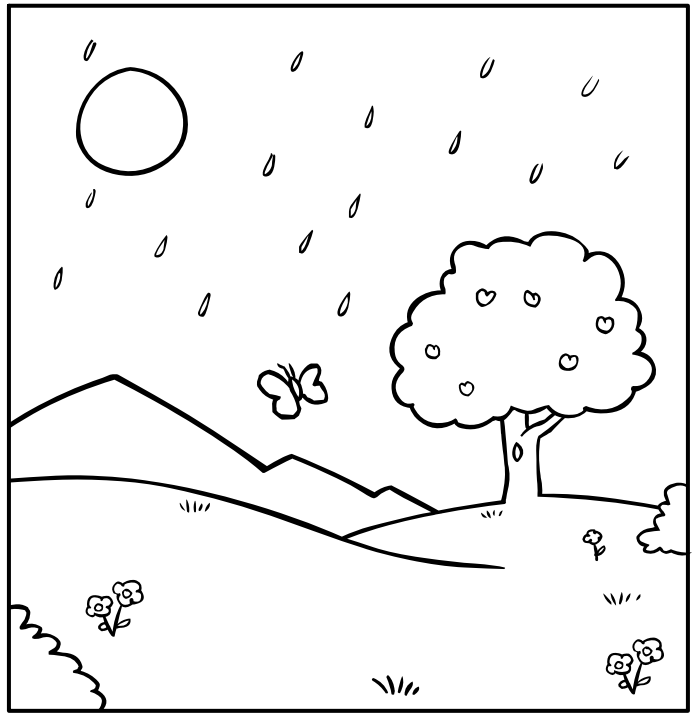
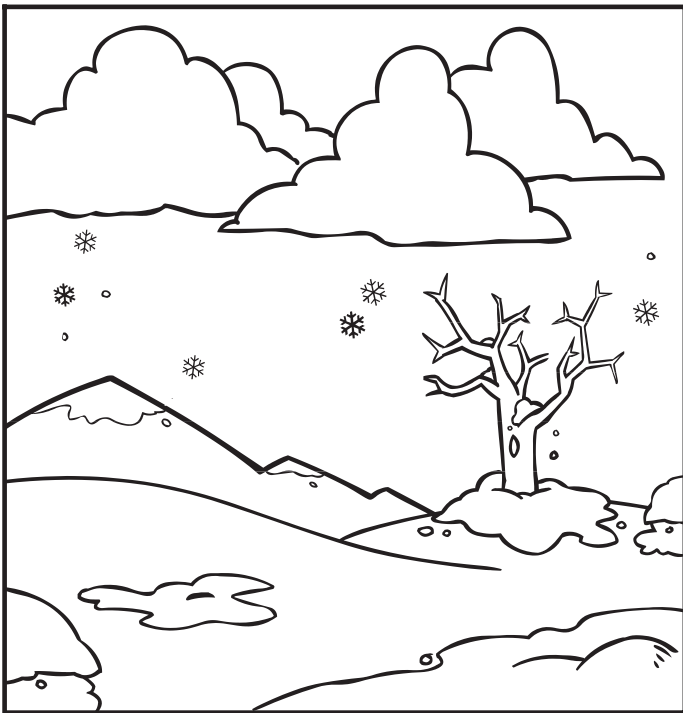
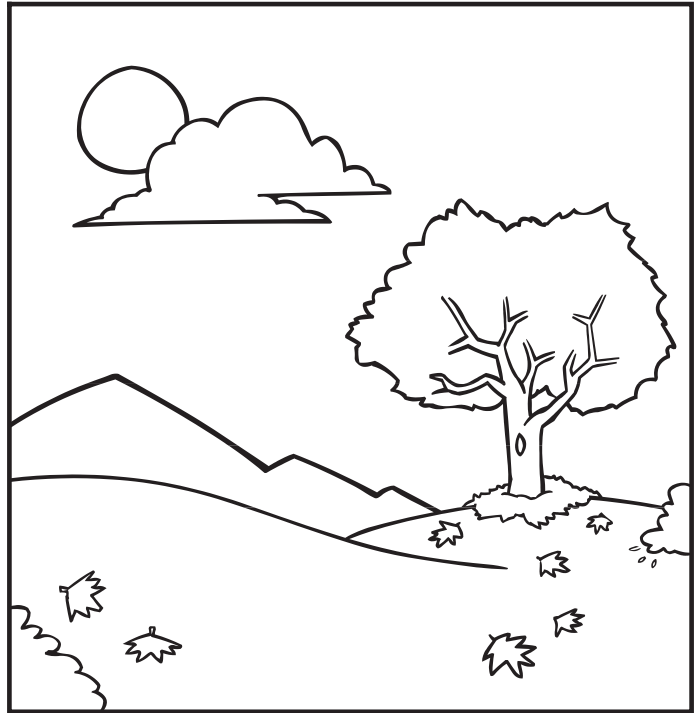
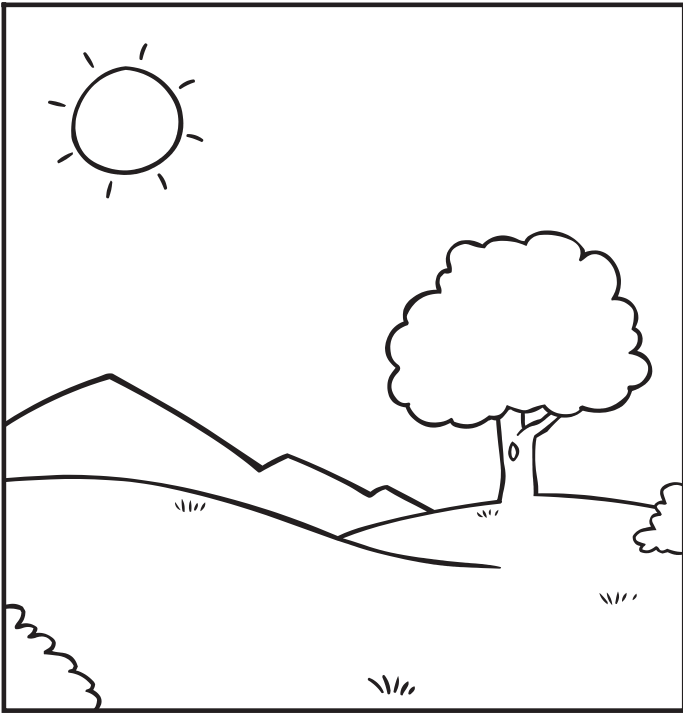

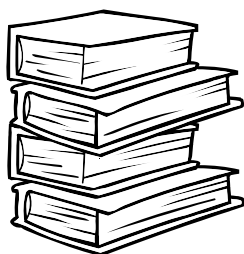
## Identifying Pictures with the Same Medial Sounds

**Directions:** Look at the pictures. Say the name of each picture aloud. Then circle the pictures that have a short /ă/ sound.

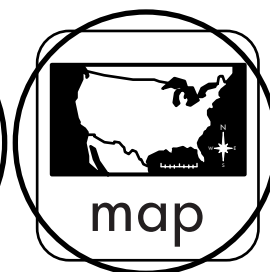
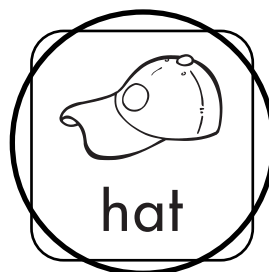
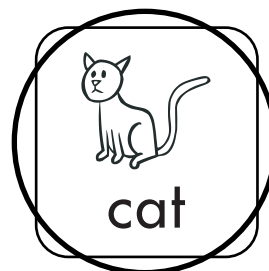
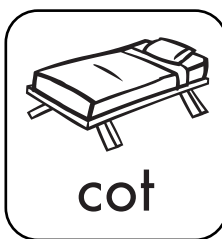
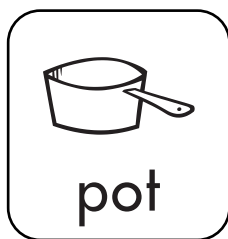
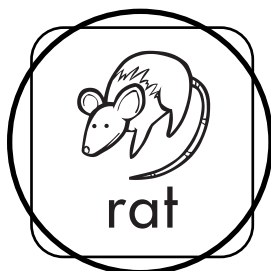

**Directions:** Cut out each picture. Match each picture to a season. Then paste the pictures in the boxes. **Answers will vary.**

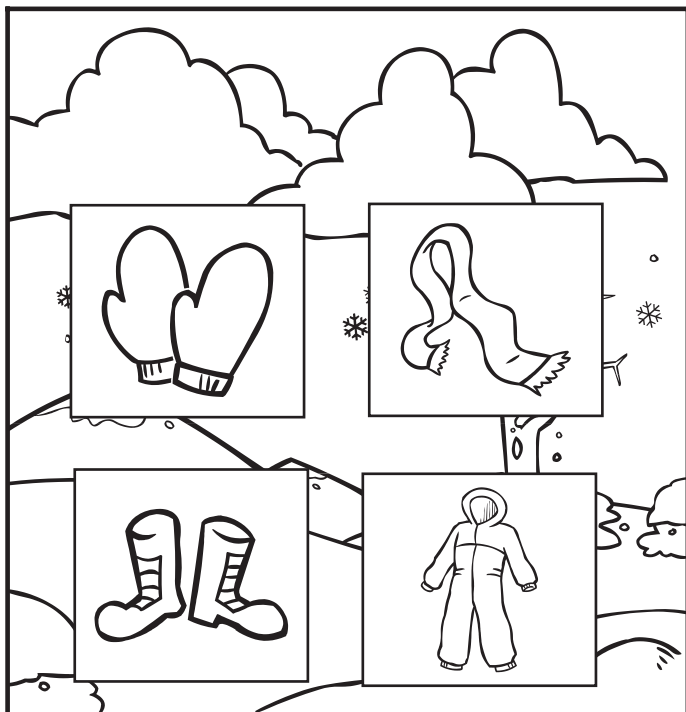
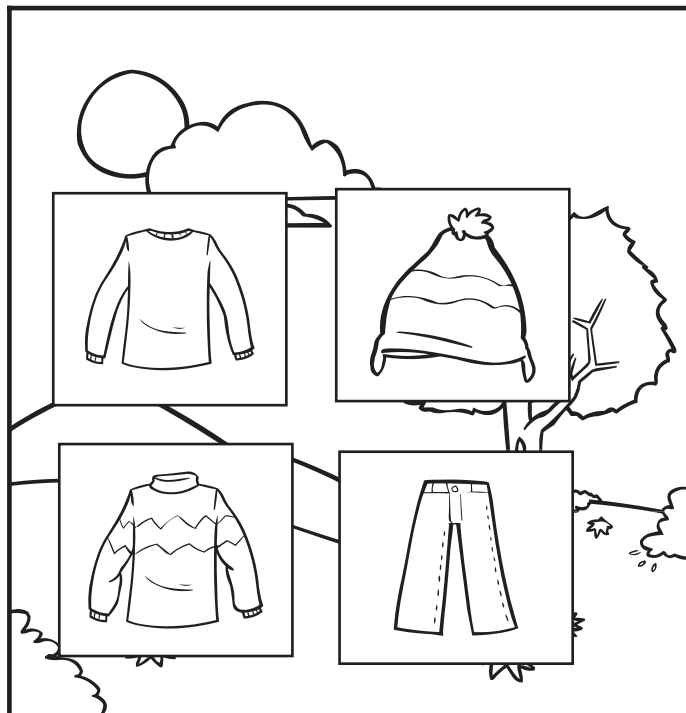
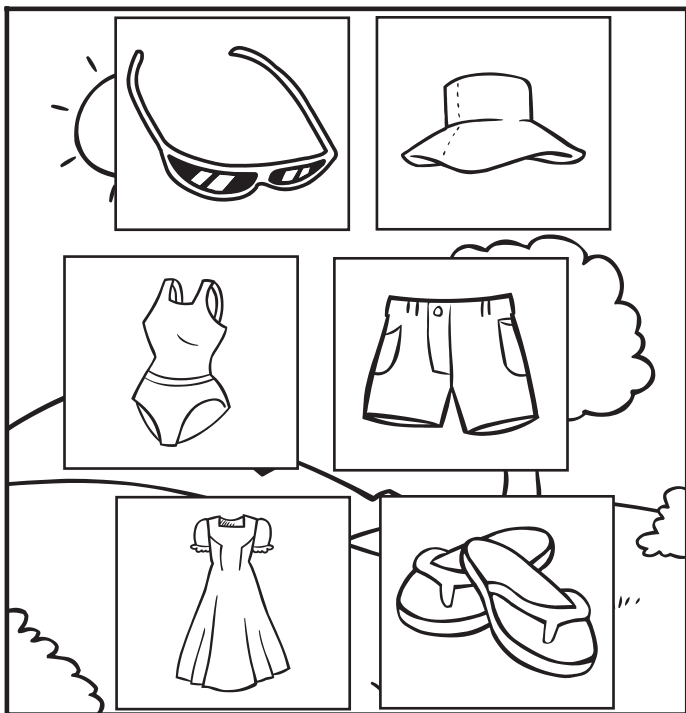





# aeiou

## Segmenting Words into Phonemes

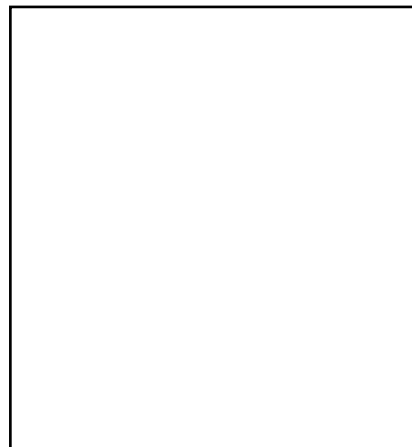
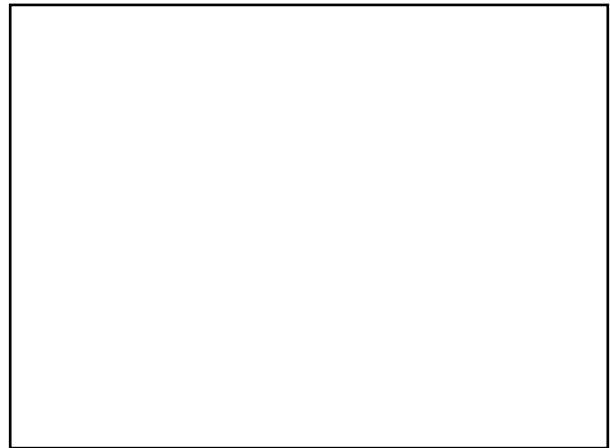
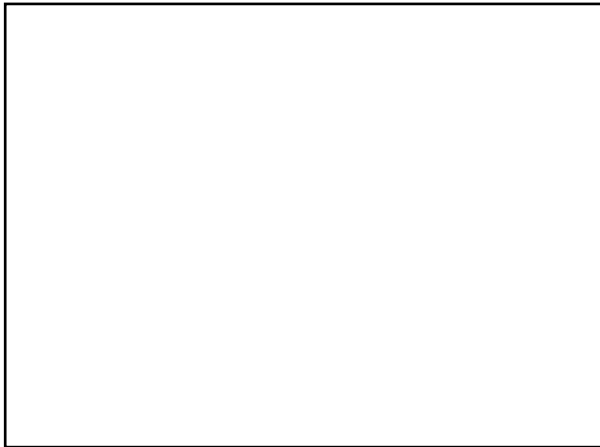
**Directions:** Cut out the puzzles. Say each sound as you build the puzzle. Paste the pieces in the boxes. Then read the word aloud.



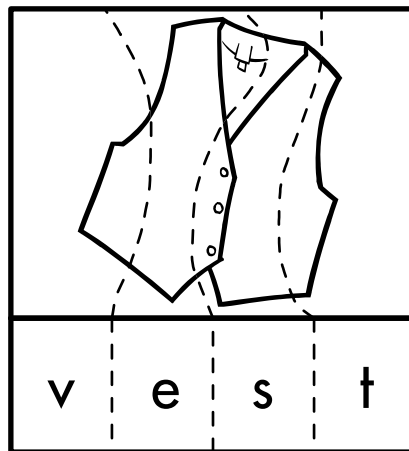
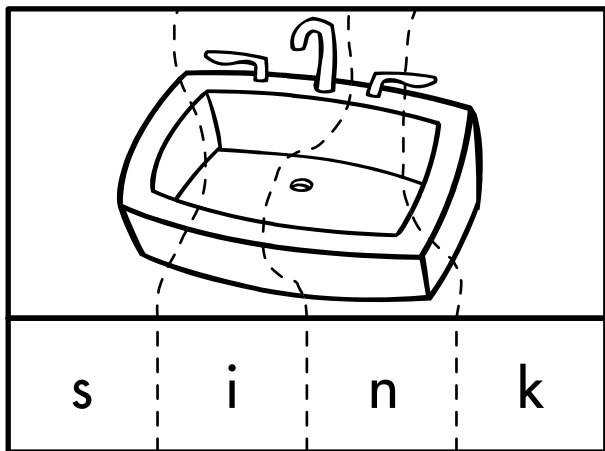
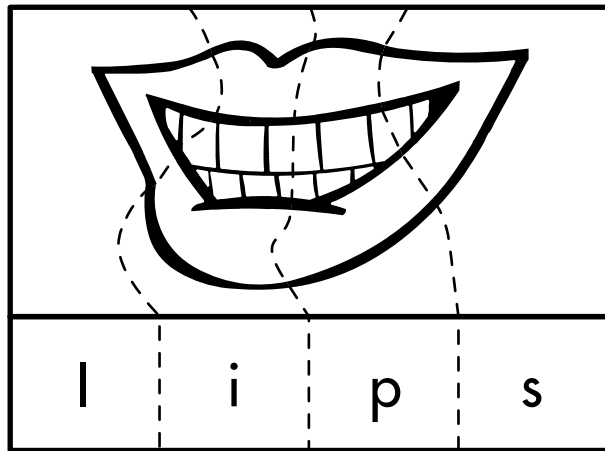
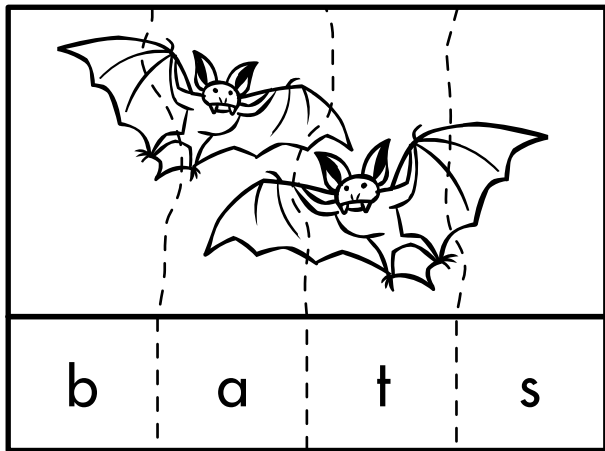

# aeiou

## Segmenting Words into Phonemes

**Directions:** Cut out the puzzles. Say each sound as you build the puzzle. Paste the pieces in the boxes. Then read the word aloud.

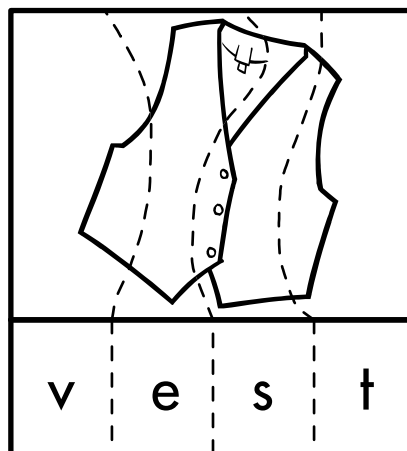
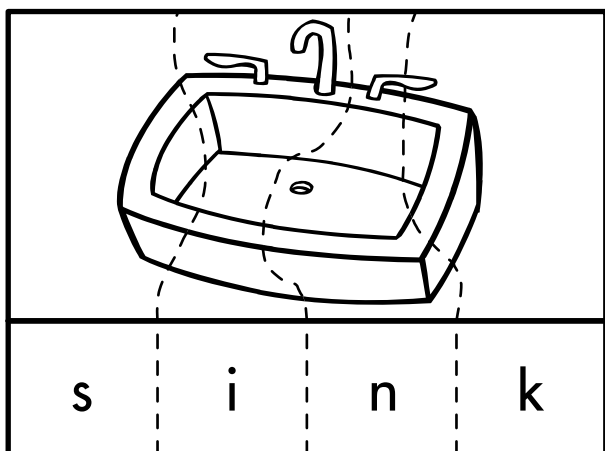
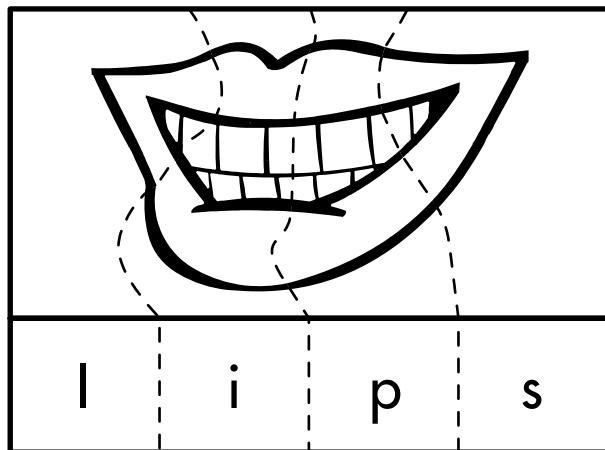
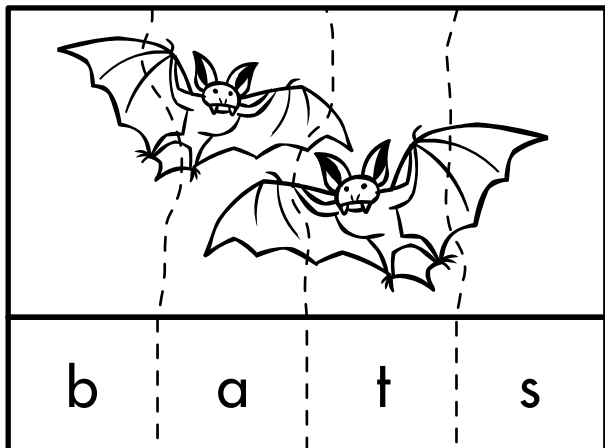

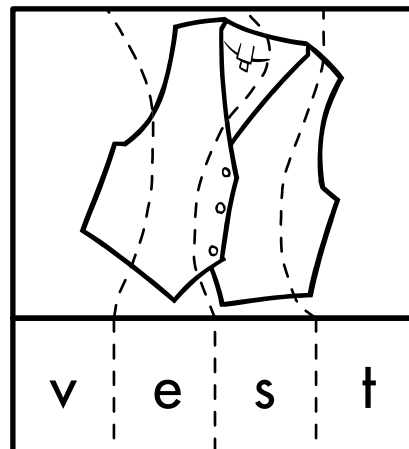
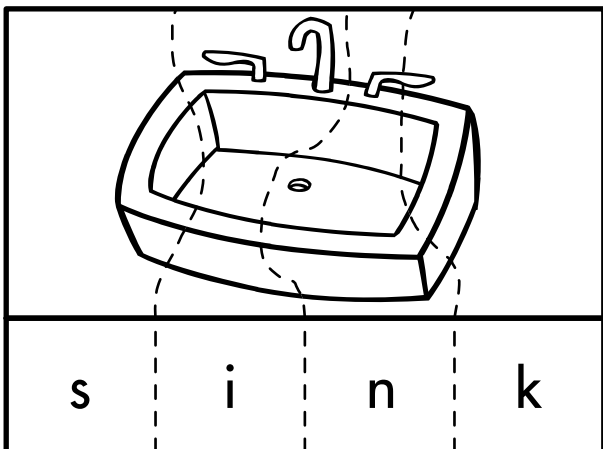
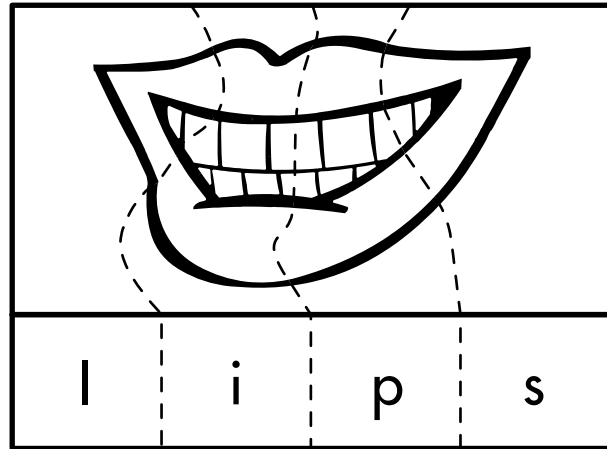
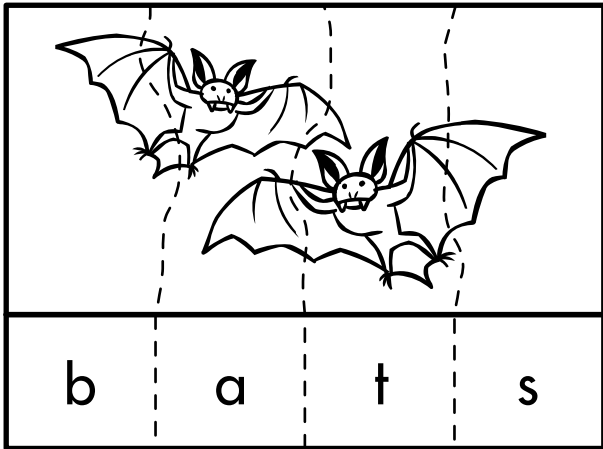

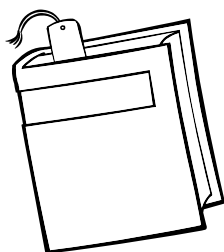

## Answering Questions about Plot

**Directions:** Cut out the pages and put them in order. Staple the pages together. Then read the story and answer the question.

### My Visit to the Doctor



by Kathryn LaComb

Name \_\_\_\_\_

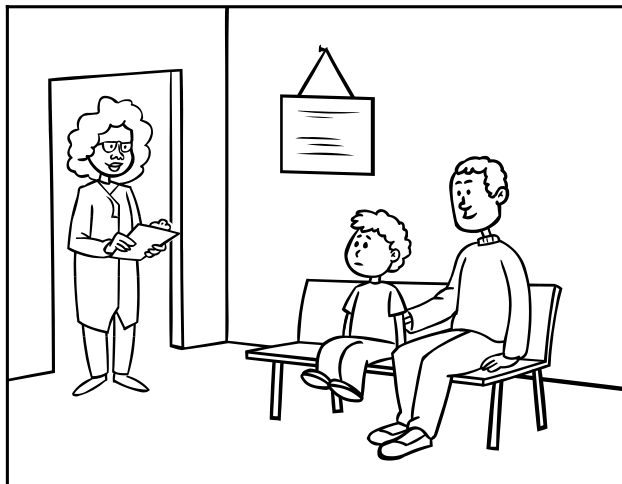

It's time for my check-up!

1



The nurse checks to see how big I am.

2

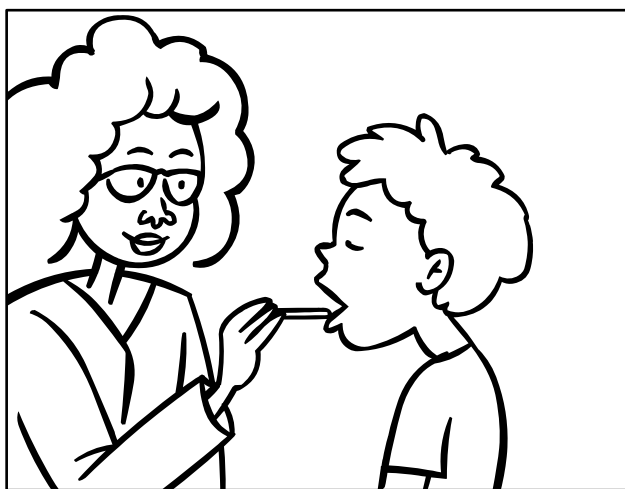

The doctor checks my ears and nose. She checks my throat.

3

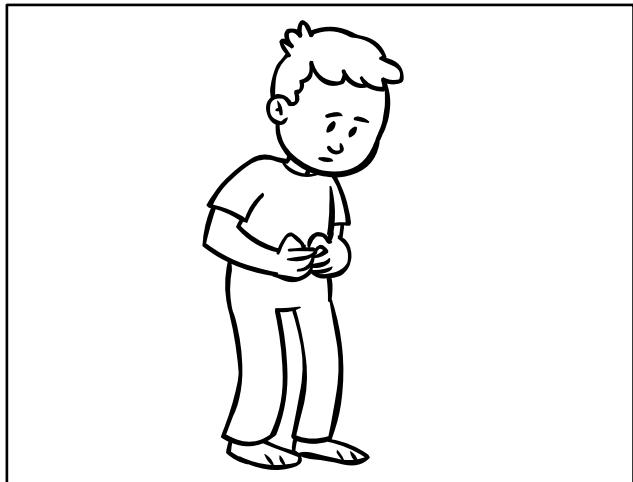

The doctor checks  
my belly.

4



The doctor checks  
my heart.

5

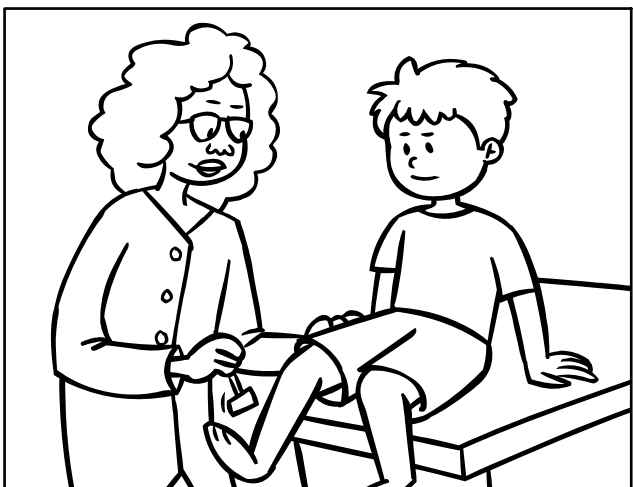

The doctor checks  
my arms and legs.

6

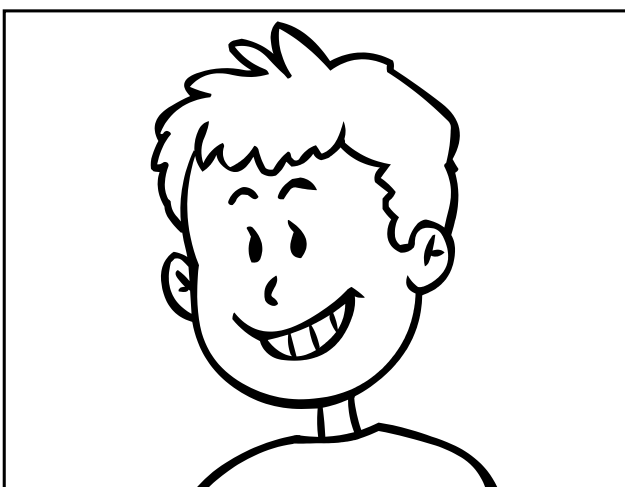

My body is healthy!  
Hooray!

7

What is something that happens at the doctor's?

\_\_\_\_\_

-----

\_\_\_\_\_

\_\_\_\_\_

-----

\_\_\_\_\_

8

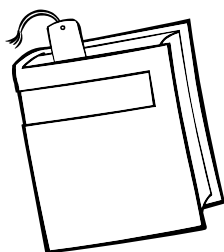

## Answering Questions about Plot

**Directions:** Cut out the pages and put them in order. Staple the pages together. Then read the story and answer the question.

### My Visit to the Doctor



by Kathryn LaComb

Name \_\_\_\_\_

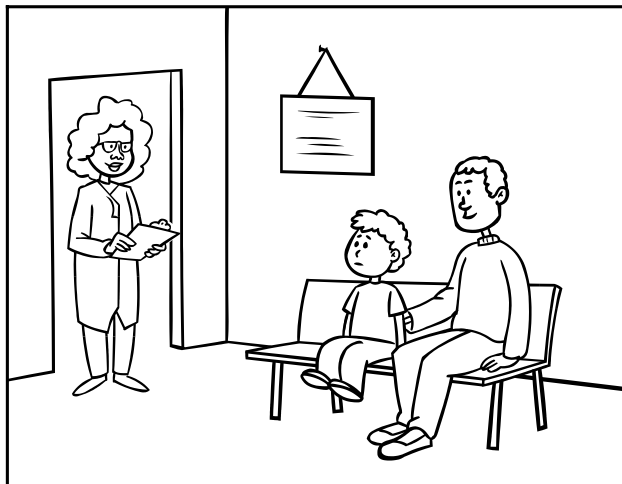

It's time for my check-up!

1



The nurse checks to see how big I am.

2

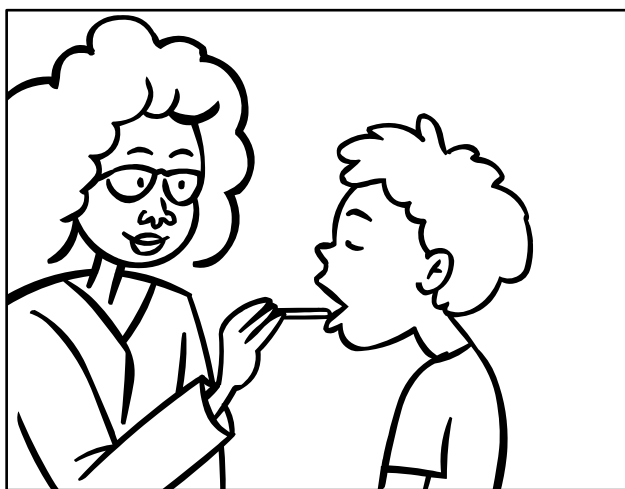

The doctor checks my ears and nose. She checks my throat.

3



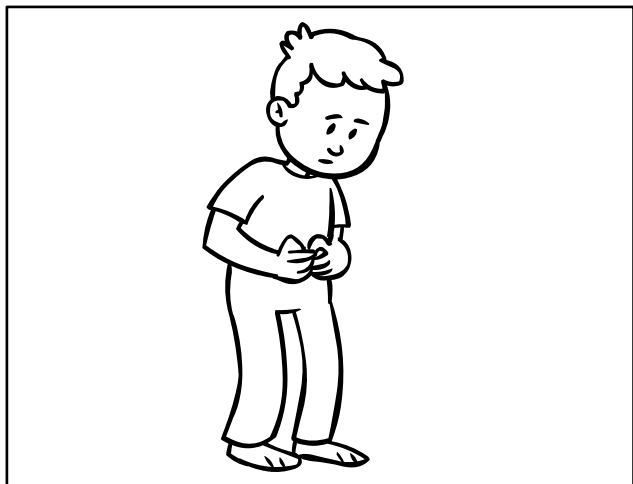

The doctor checks  
my belly.

4



The doctor checks  
my heart.

5

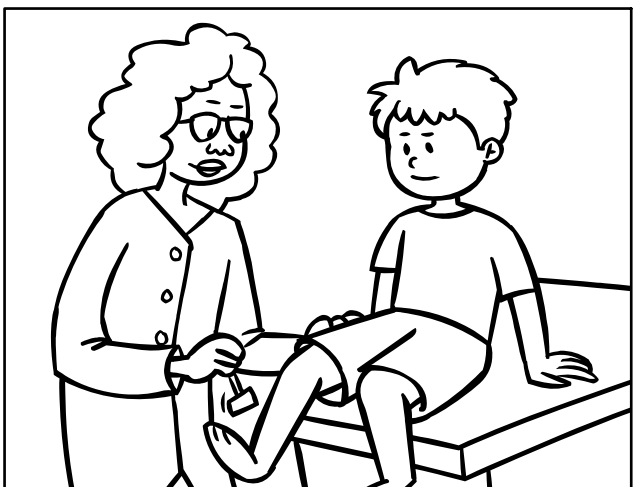

The doctor checks  
my arms and legs.

6

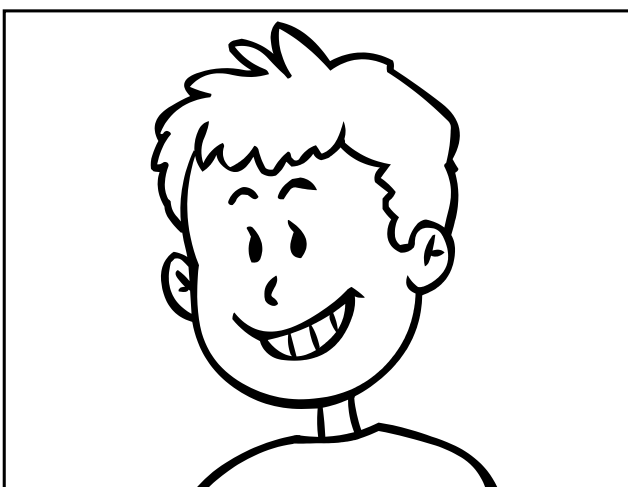

My body is healthy!  
Hooray!

7

What is something that happens at the doctor's?

**Pictures  
will vary.**

\_\_\_\_\_

**The doctor checks**

\_\_\_\_\_

-----

**my ears.**

\_\_\_\_\_

8



## aeiou Reading High Frequency Words

**Directions:** Read the story. Draw a circle around the words **and**, **of**, and **the**.

What a  day!  
sunny

Perfect for a picnic!

 brings  .  
Cat milk

 and  bring  .  
Mouse Bird cheese

 brings a  of  .  
Dog basket bread

 brings a  of  .  
Hen bowl corn

 brings  and  .  
Rabbit carrots tomatoes

Yum! Yum!

Oh no! Here come the  !  
clouds

The sky is full of  !  
rain

Plop! Plop! Drop! Drop!

The  must wait for another day.  
picnic

**Directions:** Draw a picture to answer the question.

What did one of the animals bring to the picnic?



## aeiou Reading High Frequency Words

**Directions:** Read the story. Draw a circle around the words **and**, **of**, and **the**.

What a  day!  
sunny

Perfect for a picnic!

 brings  .  
Cat milk

 **and**  bring  .  
Mouse Bird cheese

 brings a  **of**  .  
Dog basket bread

 brings a  **of**  .  
Hen bowl corn

 brings  **and**  .  
Rabbit carrots tomatoes

Yum! Yum!

Oh no! Here come **the**  !  
clouds

**The** sky is full **of**  !  
rain

Plop! Plop! Drop! Drop!

**The**  must wait for another day.  
picnic

**Directions:** Draw a picture to answer the question.

What did one of the animals bring to the picnic?

**Pictures  
will vary.**

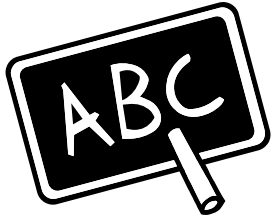

## Identifying Sound-Letter Associations

**Directions:** Look at the pictures. Say the name of each picture aloud. Then write the missing letter.

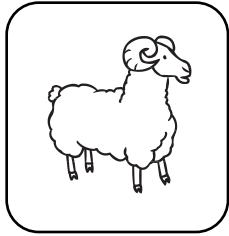

\_\_\_ a m



\_\_\_ o p

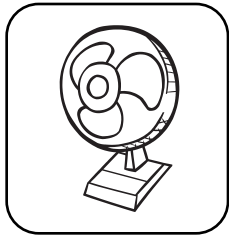

\_\_\_ a n

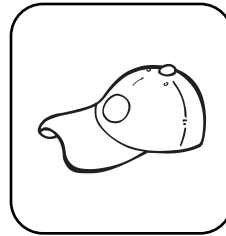

\_\_\_ a p

**Directions:** Look at the pictures. Say the name of each picture aloud. Then circle the pictures that have a short /ă/ sound.

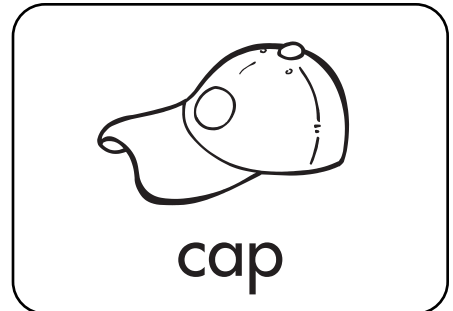
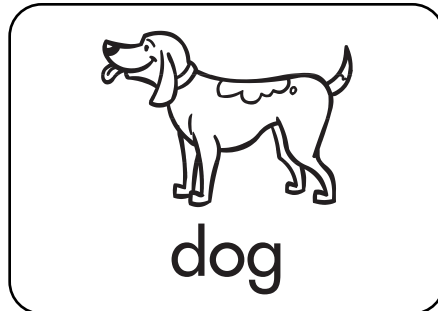
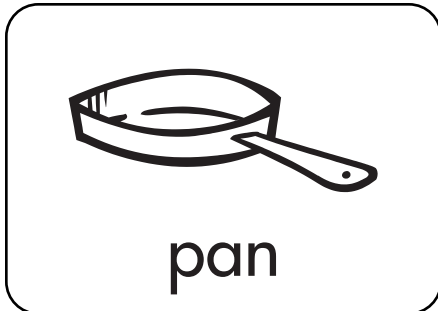

**Directions:** Cut out the puzzle. Say each sound as you build the puzzle. Then read the word aloud.

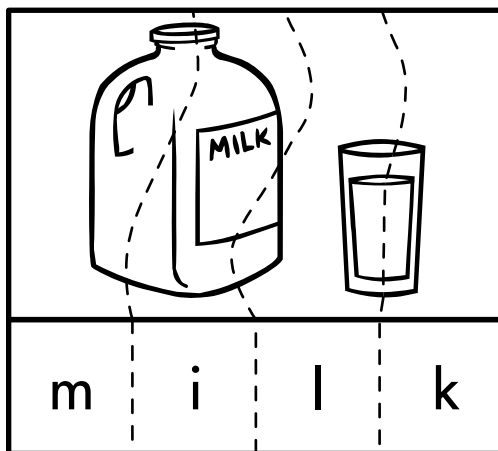



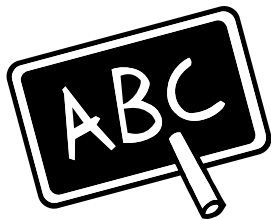

## Identifying Sound-Letter Associations

**Directions:** Look at the pictures. Say the name of each picture aloud. Then write the missing letter.

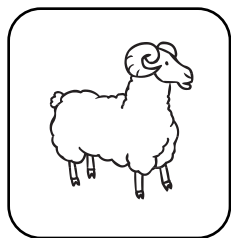

   r a m



   m o p

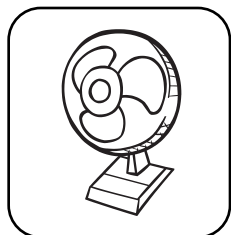

   f a n

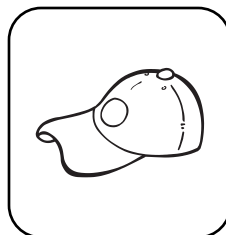

   c a p

**Directions:** Look at the pictures. Say the name of each picture aloud. Then circle the pictures that have a short /ă/ sound.

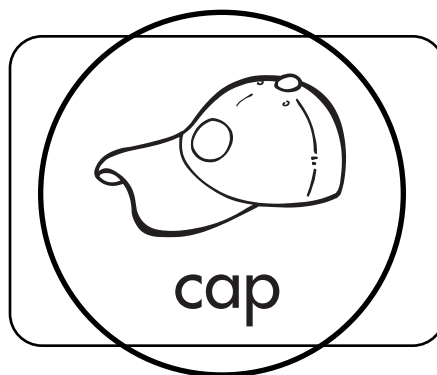
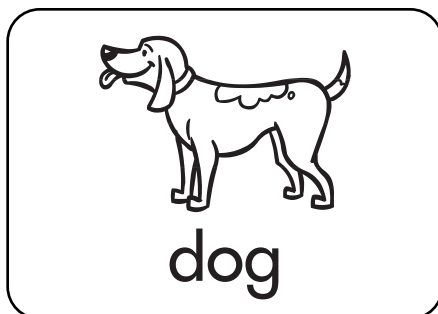
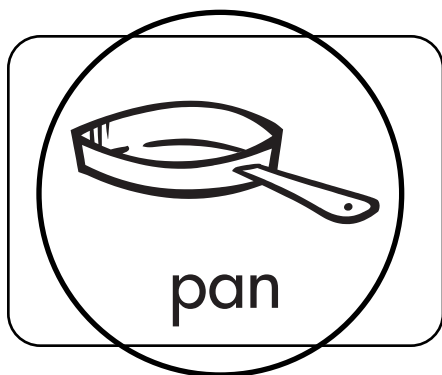

**Directions:** Cut out the puzzle. Say each sound as you build the puzzle. Then read the word aloud.

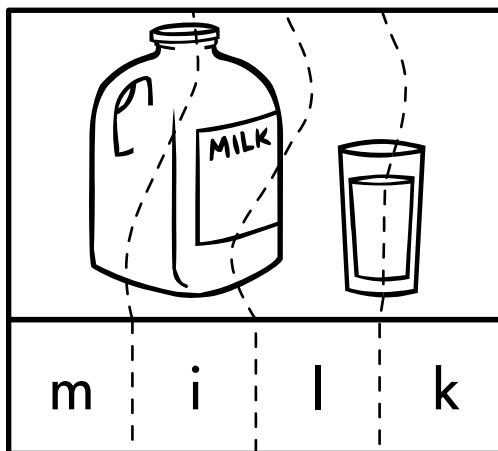



## Identifying Letter-Sound Associations

**Directions:** Draw a line from each letter to the picture with the same beginning sound.

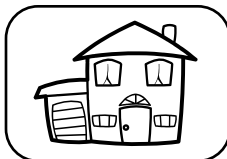
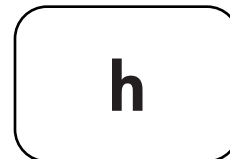
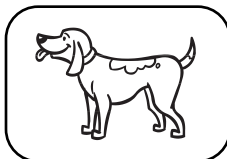
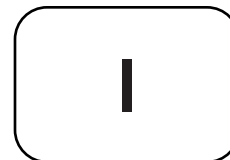
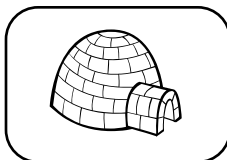
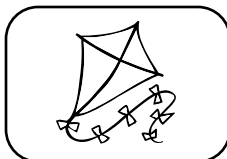

**Directions:** Look at the pictures. Say the name of each picture aloud. Then write the missing letter.

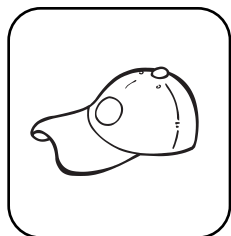

h a \_\_\_\_

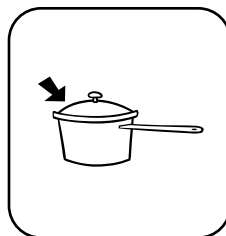

l \_\_\_\_ d

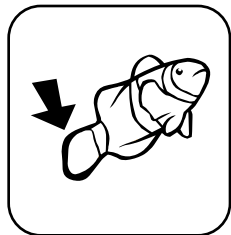

f i \_\_\_\_

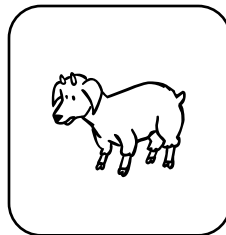

k \_\_\_\_ d

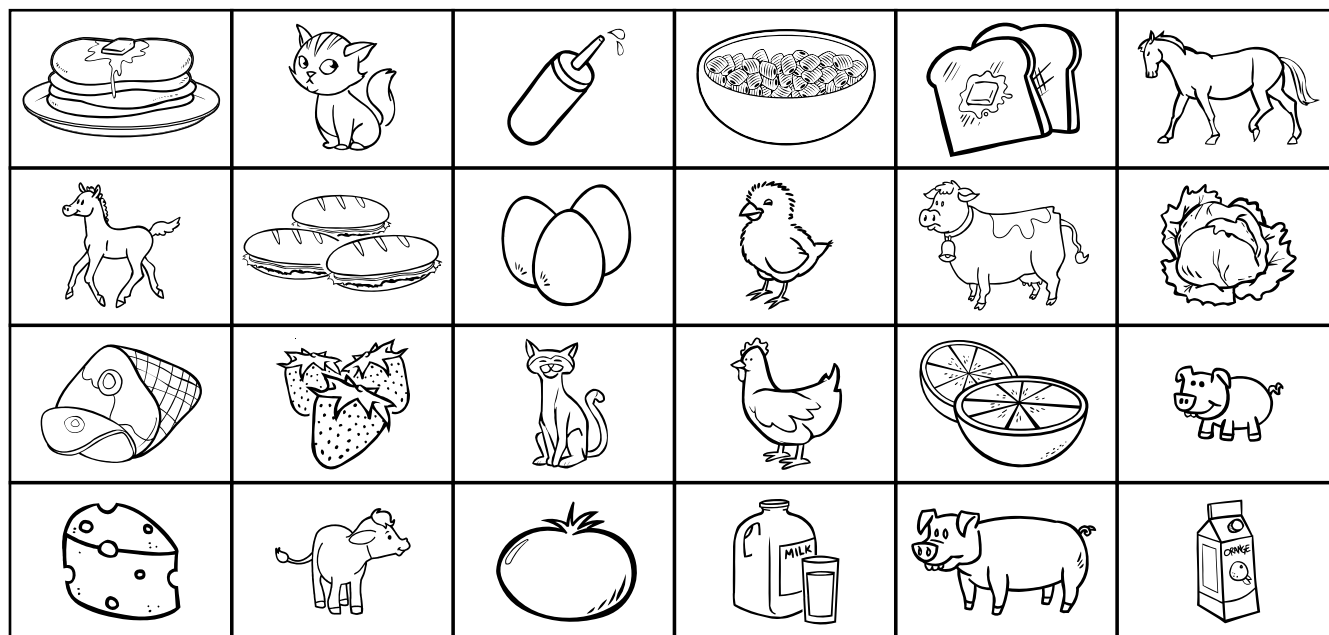

**Directions:** Cut out the pictures. Sort them into groups. Then paste them in the boxes.

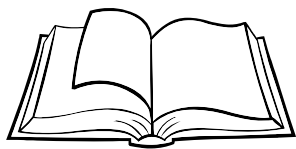

## Identifying Letter-Sound Associations

**Directions:** Draw a line from each letter to the picture with the same beginning sound.

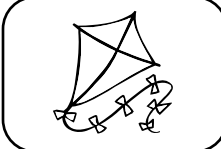
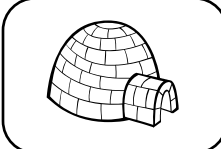
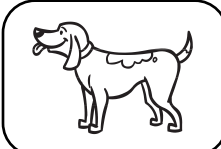
D				k
H				l
I				h
K				d
L				i

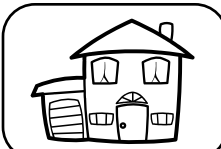
**Directions:** Look at the pictures. Say the name of each picture aloud. Then write the missing letter.

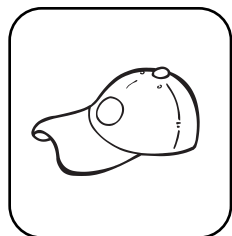

h a    t

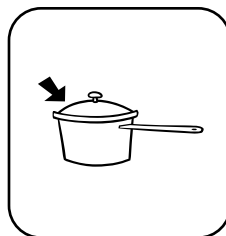

l    i d

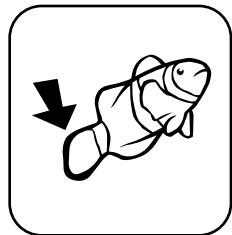



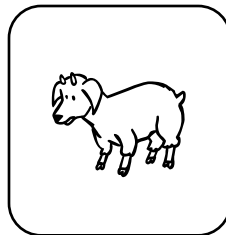







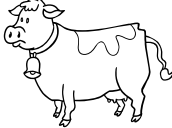



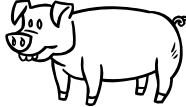
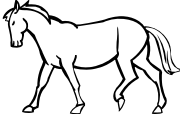

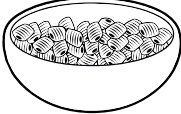

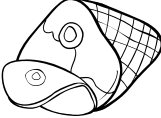
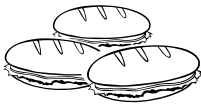

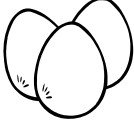

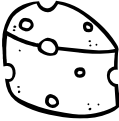









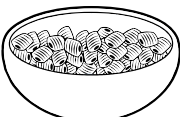

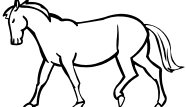

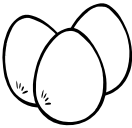

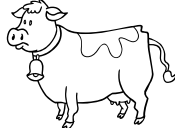

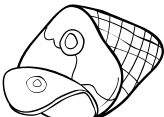

f i    n

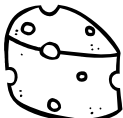

k    i d

**Directions:** Cut out the pictures. Sort them into groups. Then paste them in the boxes. **Answers will vary.**

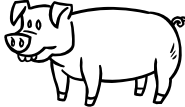

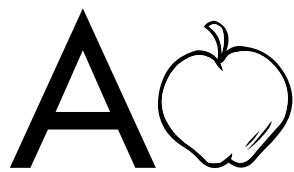

## Using Picture Boxes to Segment Sounds

**Directions:** Draw a line to match the baby animal to its mother.

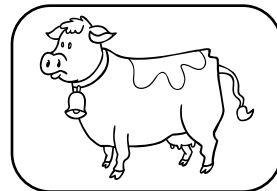
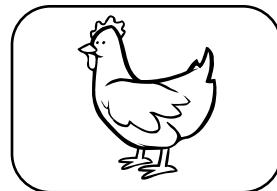
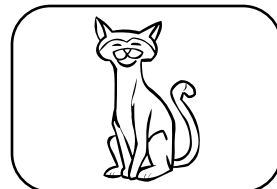
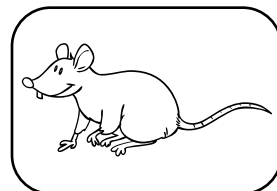
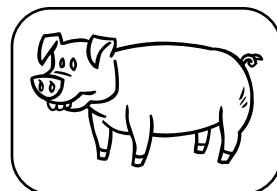
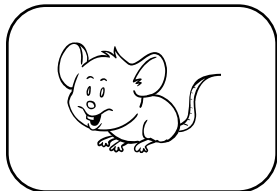
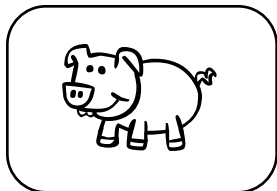
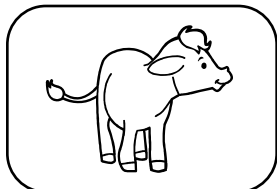
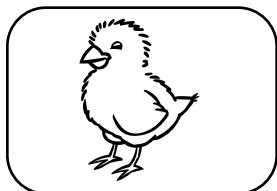

**Directions:** Cut out the puzzles. Say each sound as you build the puzzle. Then read the word aloud.

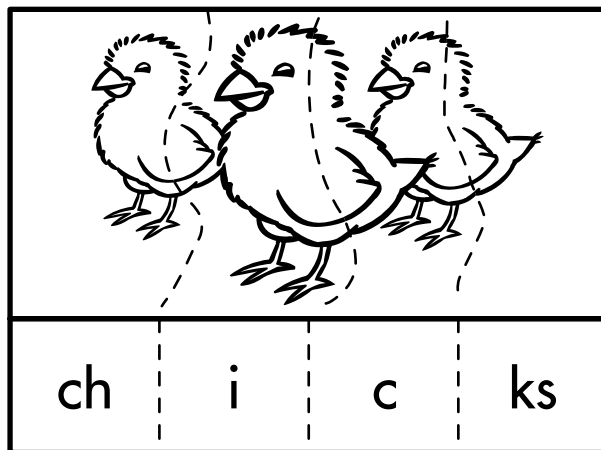
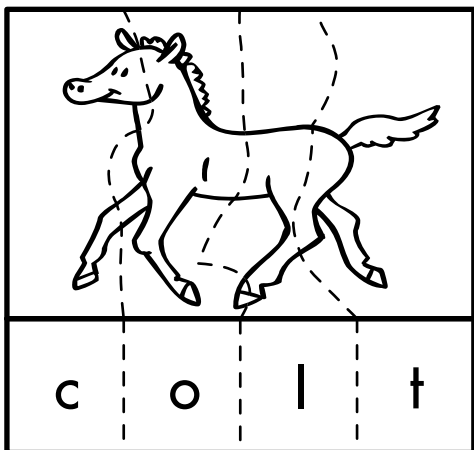
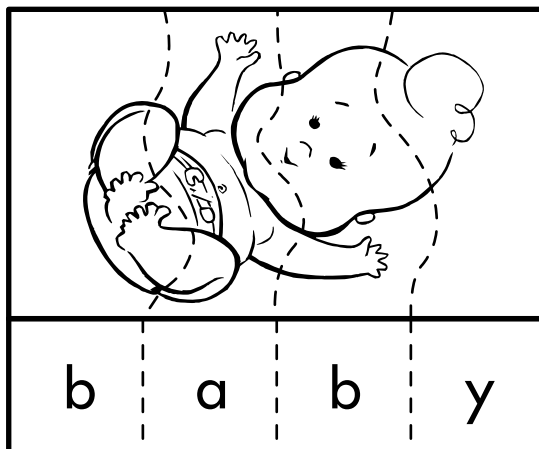
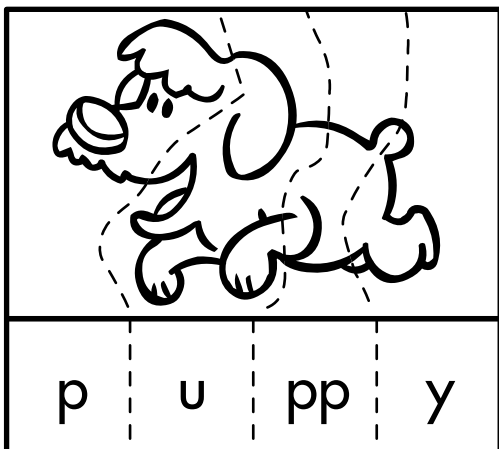



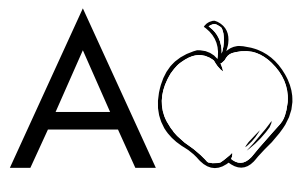

## Using Picture Boxes to Segment Sounds

**Directions:** Draw a line to match the baby animal to its mother.

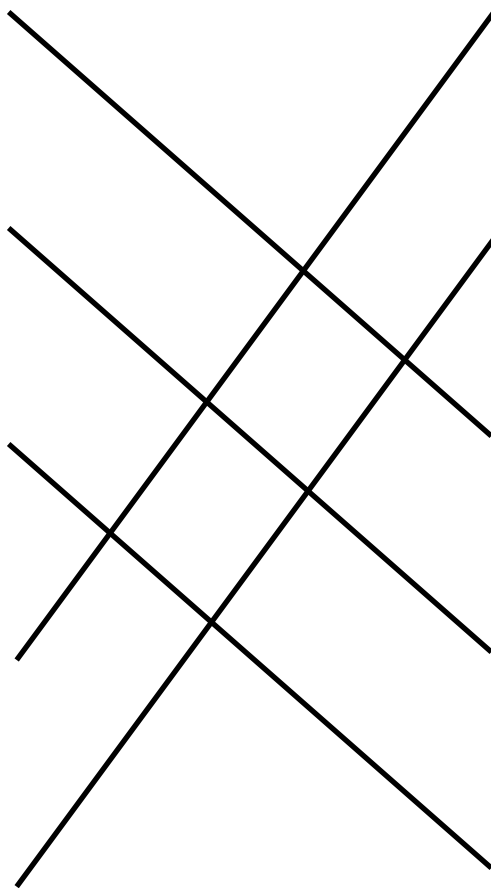
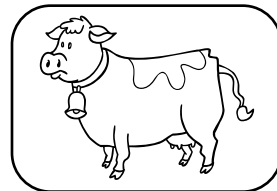
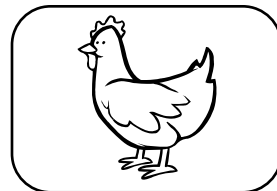
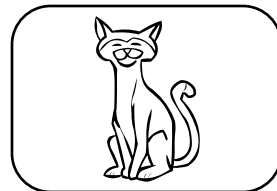
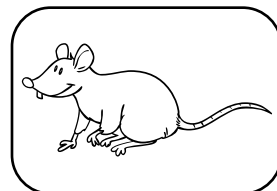
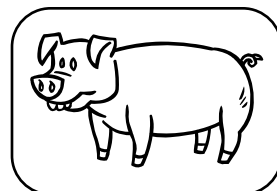
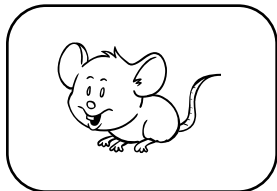
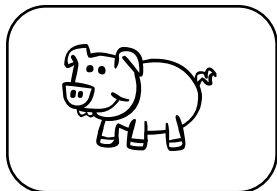
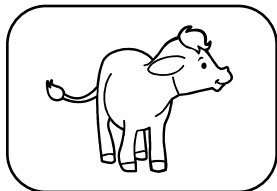
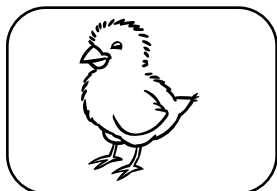

**Directions:** Cut out the puzzles. Say each sound as you build the puzzle. Then read the word aloud.

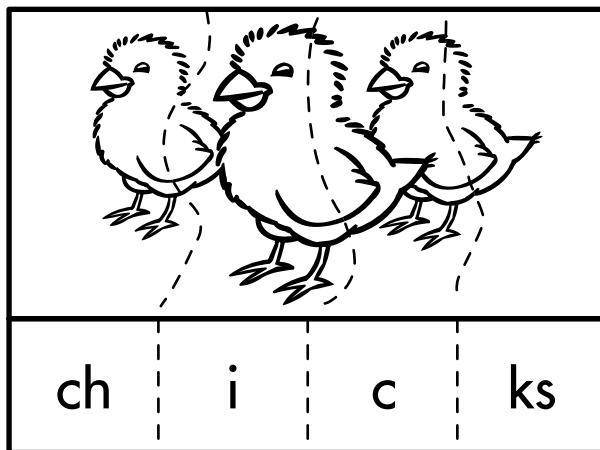
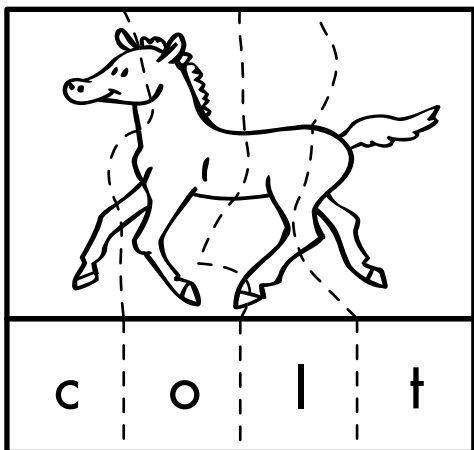
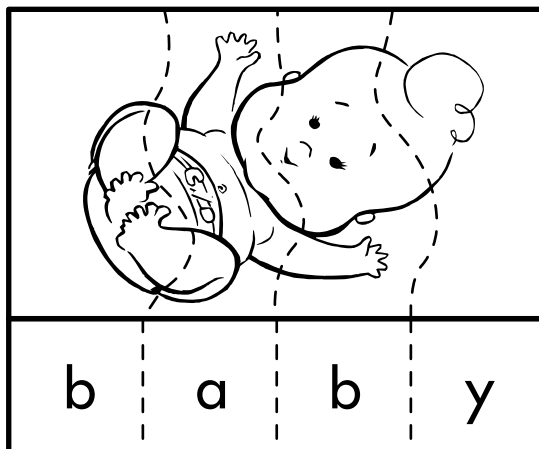
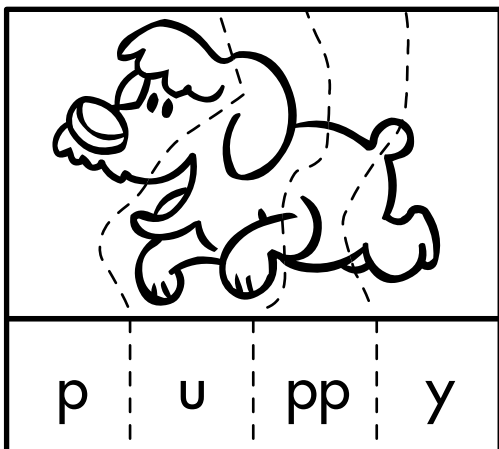

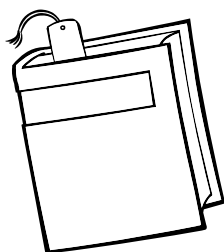

## Answering Questions about Plot

**Directions:** Cut out the pages and put them in order. Staple them together. Then read the story and answer the question.

### The Missing Chick

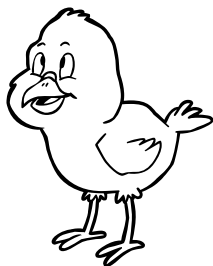

by Wendi Silvano

Name \_\_\_\_\_

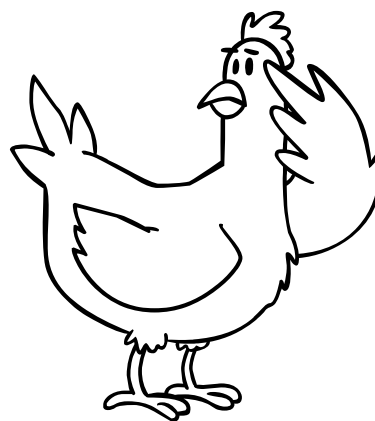

Hen could not find her littlest chick.

1

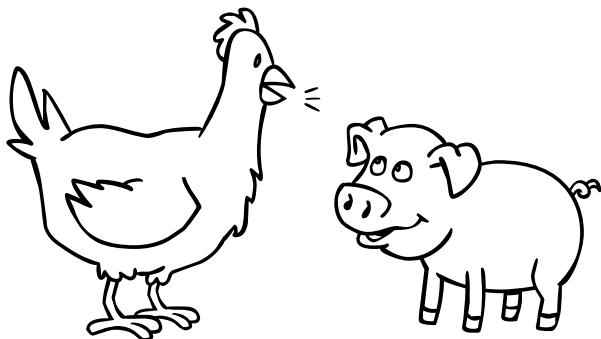

Hen asked Piglet, "Have you seen my littlest chick?"  
Piglet said, "No." 2

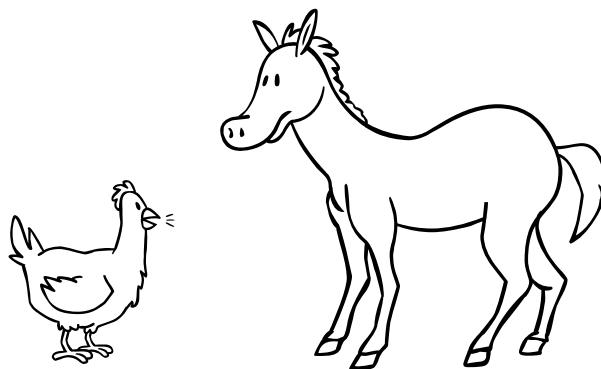

Hen asked Colt, "Have you seen my littlest chick?"  
Colt said, "No." 3

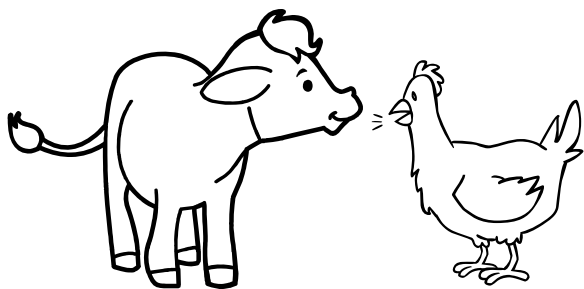

Hen asked Calf, "Have you seen my littlest chick?"  
Calf said, "No." 4

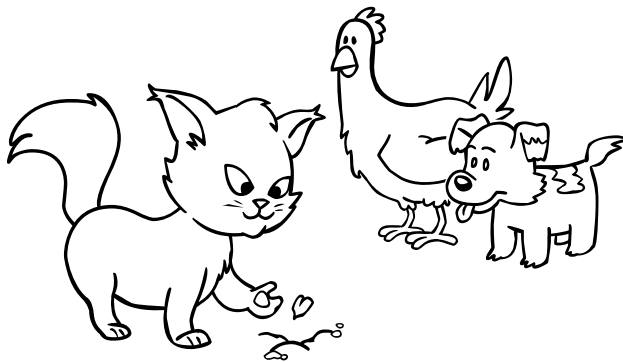

Hen asked Puppy and Kitten for help. Kitten put corn kernels on the ground. 5

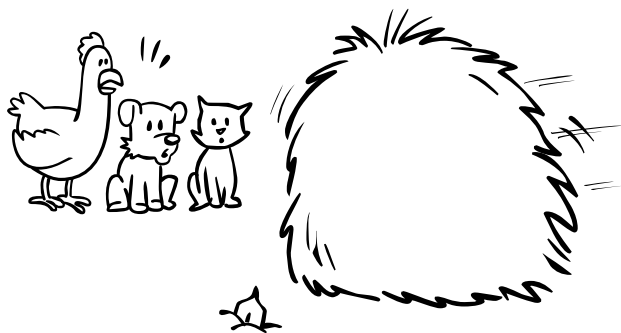

Soon something moved in the haystack. Out came Hen's littlest chick! 6

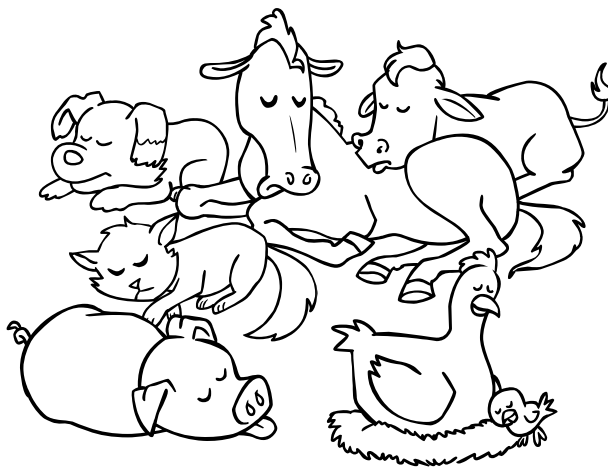

And all the animals went back to bed. 7

What happens at the beginning of the story?

\_\_\_\_\_

-----

\_\_\_\_\_

\_\_\_\_\_

-----

\_\_\_\_\_

8

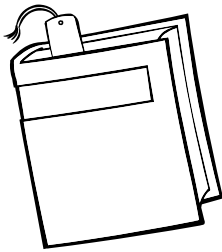

## Answering Questions about Plot

**Directions:** Cut out the pages and put them in order. Staple them together. Then read the story and answer the question.

### The Missing Chick

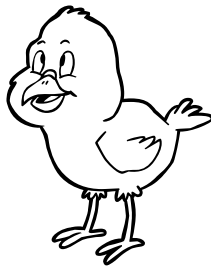

by Wendi Silvano

Name \_\_\_\_\_

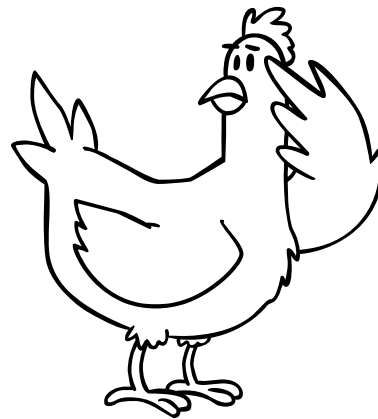

Hen could not find her littlest chick.

1

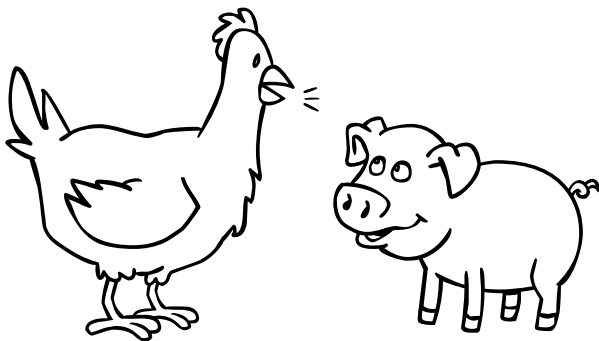

Hen asked Piglet, "Have you seen my littlest chick?"  
Piglet said, "No." 2

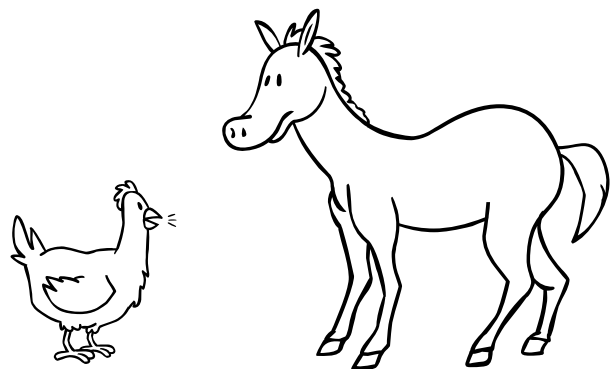

Hen asked Colt, "Have you seen my littlest chick?"  
Colt said, "No." 3

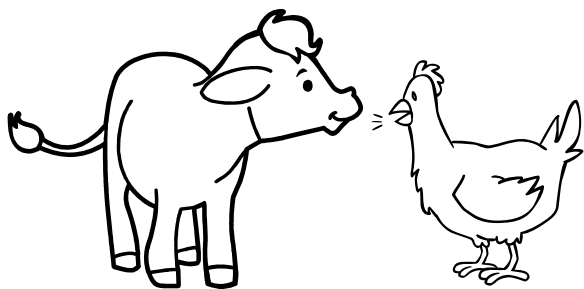

Hen asked Calf, "Have you seen my littlest chick?"  
Calf said, "No." 4

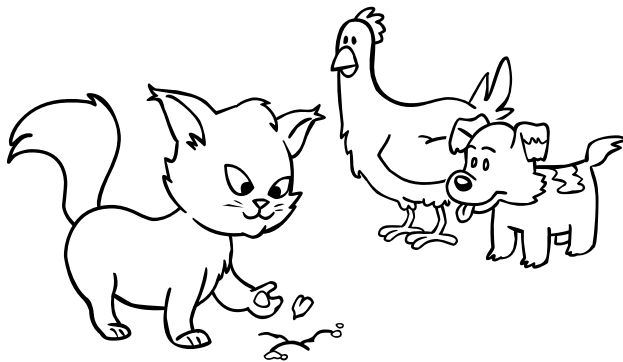

Hen asked Puppy and Kitten for help. Kitten put corn kernels on the ground. 5

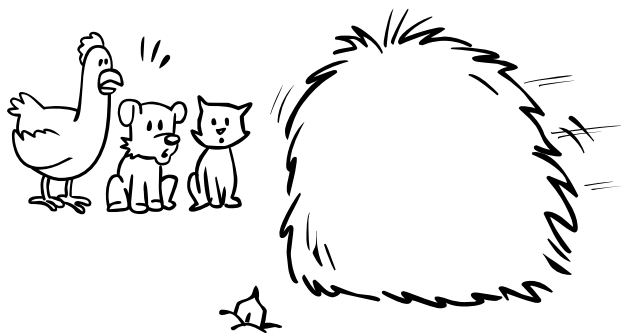

Soon something moved in the haystack. Out came Hen's littlest chick! 6

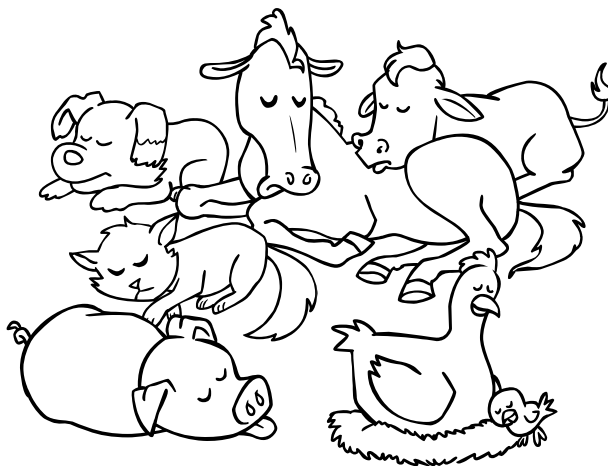

And all the animals went back to bed. 7

What happens at the beginning of the story?

**Pictures  
will vary.**

\_\_\_\_\_

**Hen could not find**

\_\_\_\_\_

**her chick.**

\_\_\_\_\_

**8**



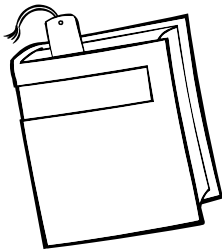

## Reading High Frequency Words

**Directions:** Cut out the pages and put them in order.  
Staple the pages together. Then read the story and circle  
the words **a**, **to**, and **in**.

### Tim and Dan



by Tricia Kauffman

Name \_\_\_\_\_

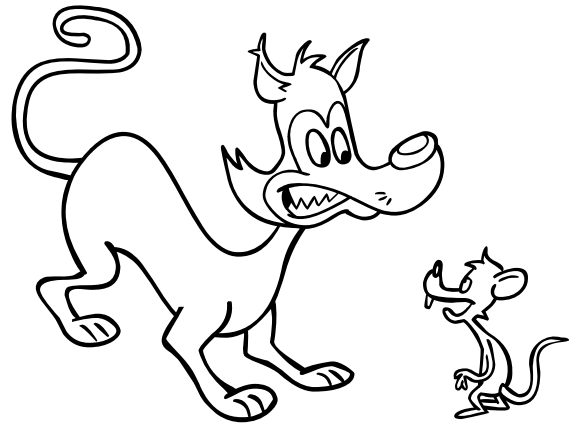

Tim and Dan hid.

1

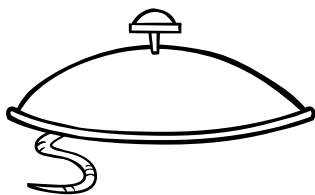

Tim hid in a lid.

2



Dan ran to the lid.

3



Dan hid in a pot.

4

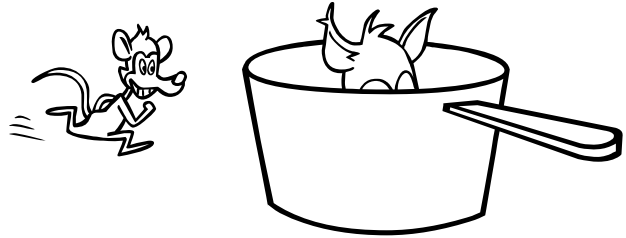

Tim ran to the pot.

5

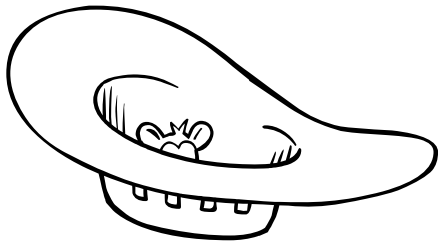

Tim hid in a hat.

6

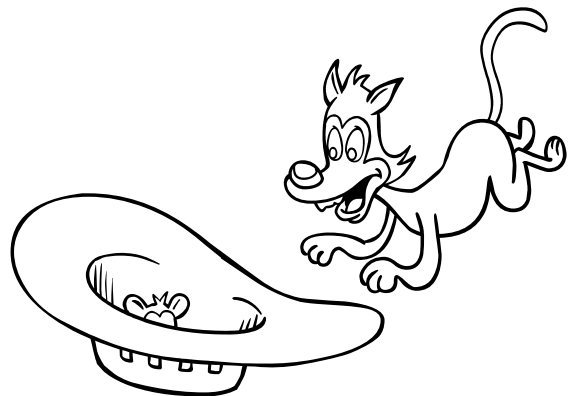

Dan ran to the hat.

7

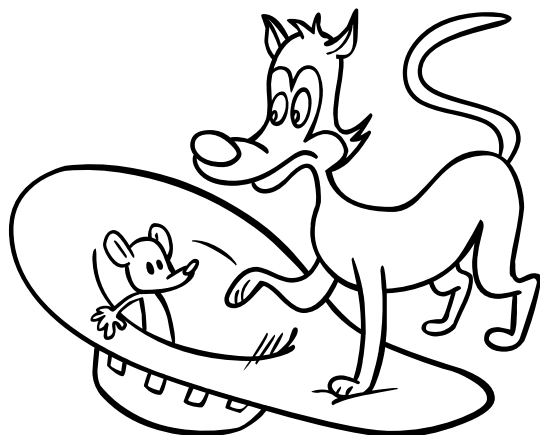

Dan is in the hat.

8

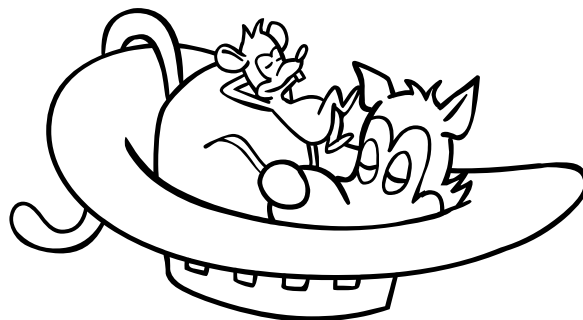

Tim and Dan had  
a nap.

9

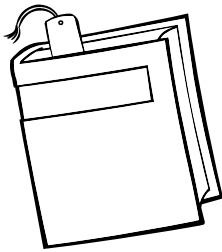

## Reading High Frequency Words

**Directions:** Cut out the pages and put them in order. Staple the pages together. Then read the story and circle the words **a**, **to**, and **in**.

### Tim and Dan



by Tricia Kauffman

Name \_\_\_\_\_

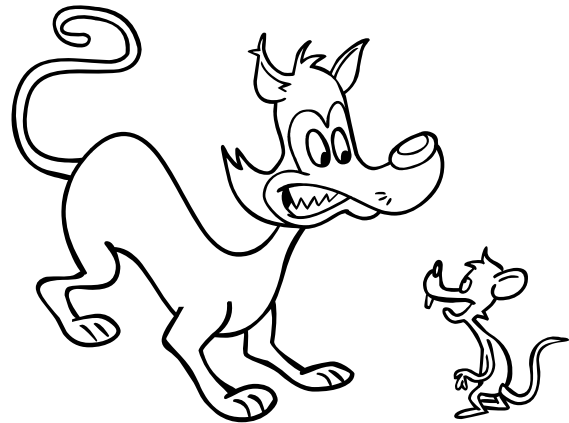

Tim and Dan hid.

1

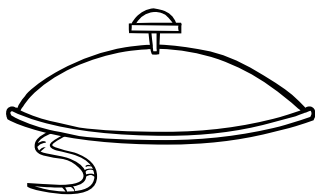

Tim hid **in** a lid.

2



Dan ran **to** the lid.

3

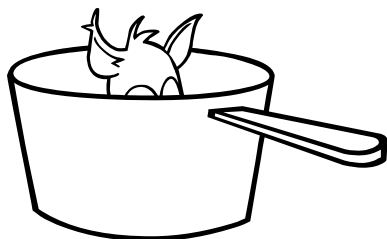

Dan hid **in** a pot.

4



Tim ran **to** the pot.

5

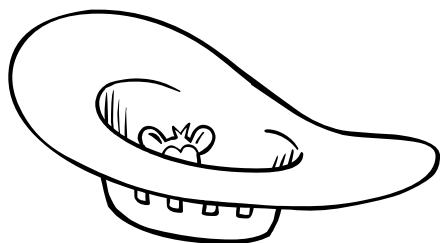

Tim hid **in** a hat.

6



Dan ran **to** the hat.

7

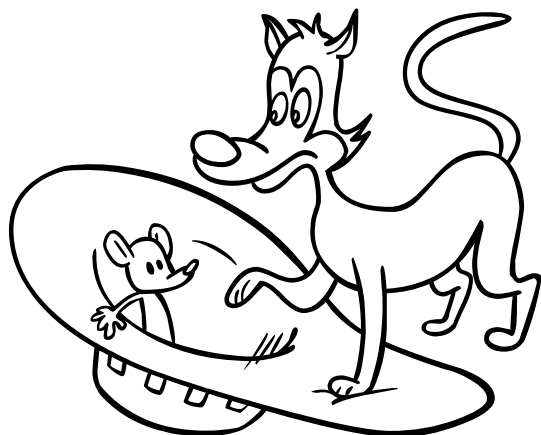

Dan is **(in)** the hat.

8

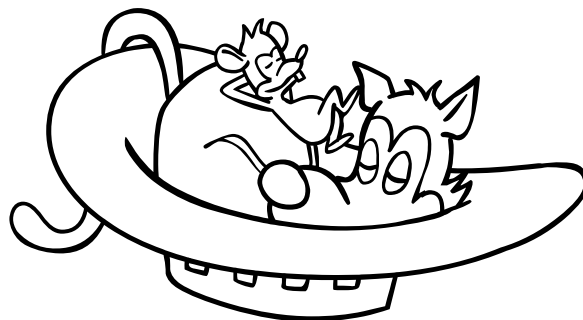

Tim and Dan had  
**(a)** nap.

9

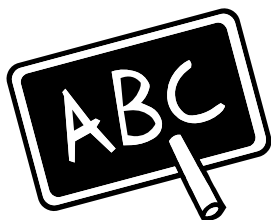

## Identifying Sound-Letter Associations and Reading High Frequency Words

**Directions:** In each box, draw a picture that begins with the letter.

Dd

Hh

Kk

Ll

**Directions:** Look at the pictures. Circle the picture that shows what happens at the beginning of the story.

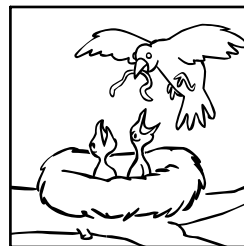
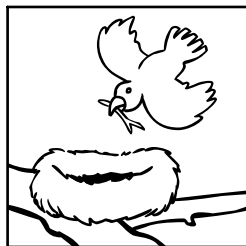

**Directions:** Read each sentence. Then circle the words **a**, **to**, and **in**.

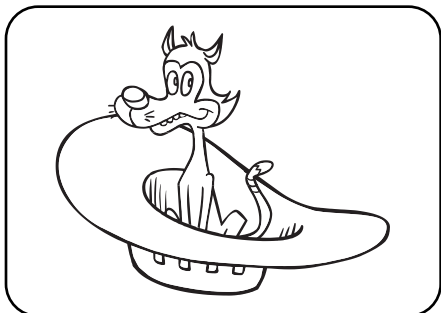

A cat sat in the hat.

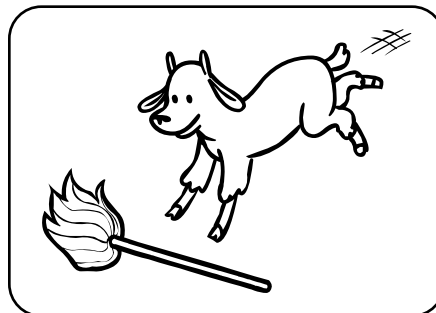

A kid ran to the mop.

**Directions:** Cut out the pictures. Sort them into groups. Then paste them in the boxes.

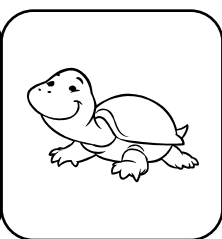
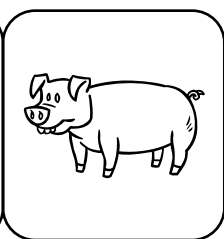
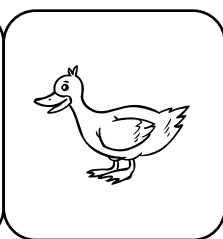
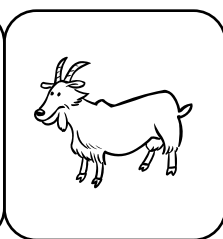
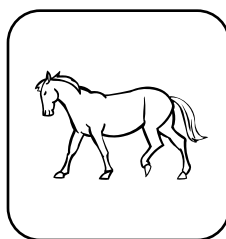
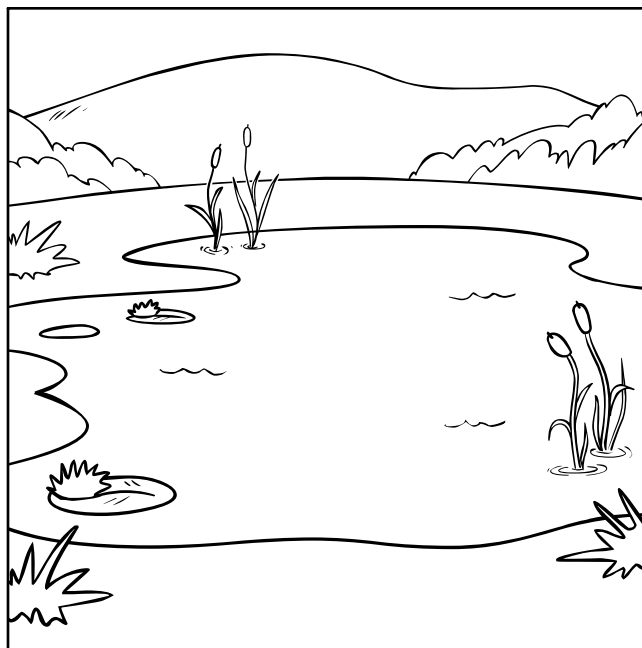
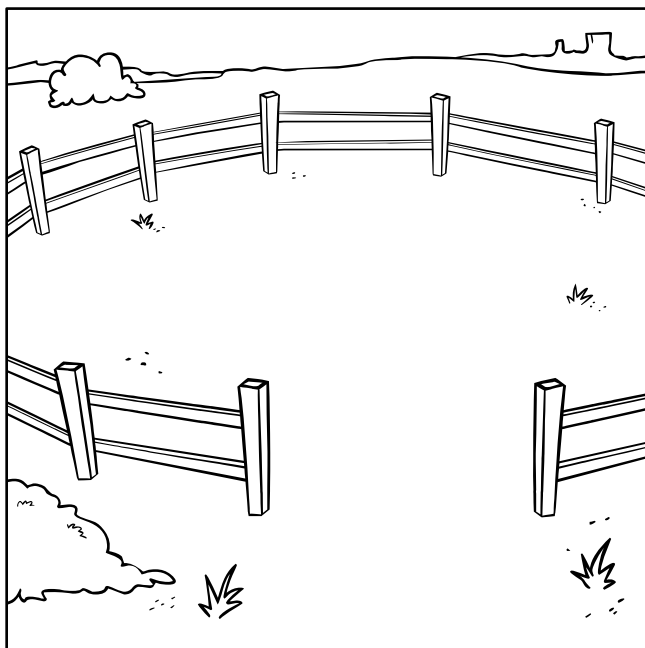



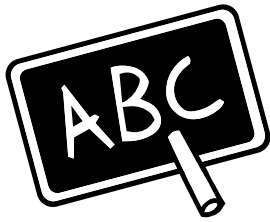

## Identifying Sound-Letter Associations and Reading High Frequency Words

**Directions:** In each box, draw a picture that begins with the letter. **Answers will vary.**

Dd

Hh

Kk

Ll

**Directions:** Look at the pictures. Circle the picture that shows what happens at the beginning of the story.

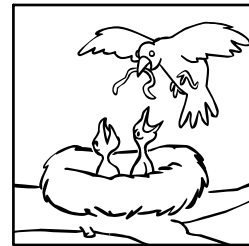
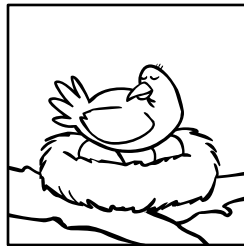
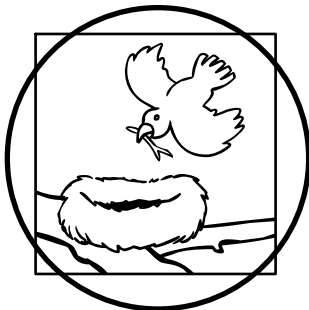

**Directions:** Read each sentence. Then circle the words **a**, **to**, and **in**.

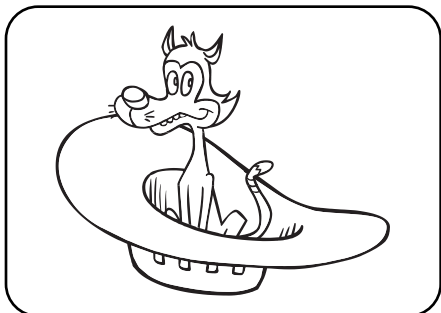

A cat sat in the hat.

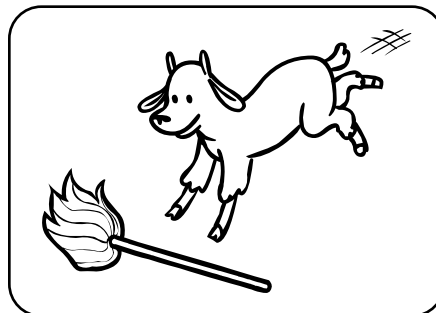

A kid ran to the mop.

**Directions:** Cut out the pictures. Sort them into groups. Then paste them in the boxes.

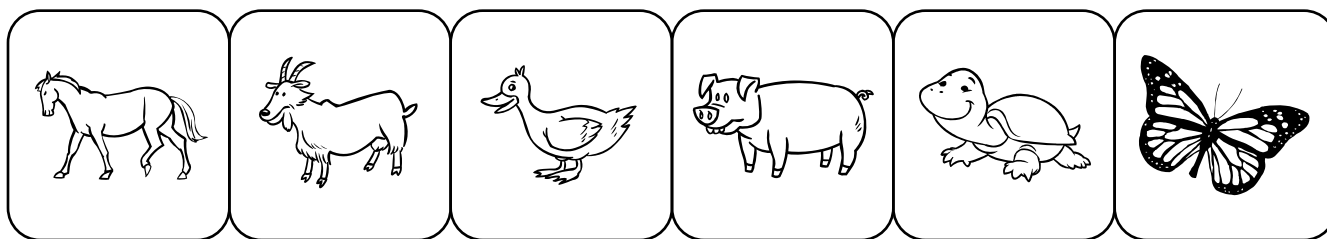
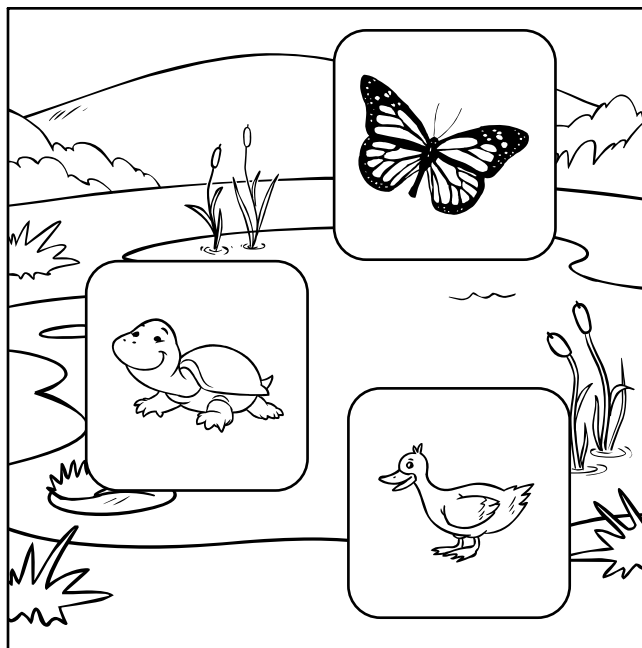
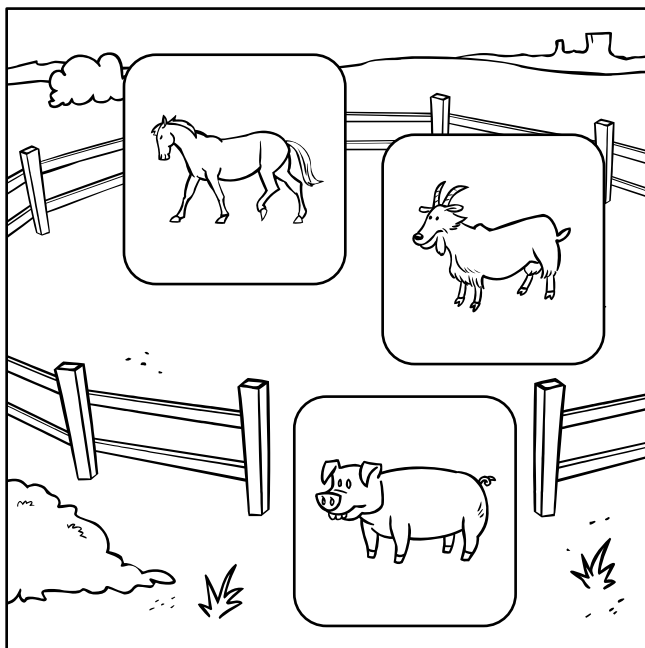

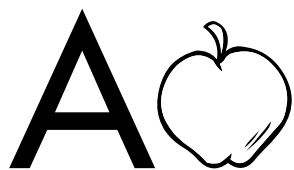

## Identifying Sound-Letter Associations

**Directions:** Read the word by sounding out each letter.  
Draw a picture to match the word.

bag

dog

cup

**Directions:** Look at the pictures. Say the name of each picture aloud. Then write the missing letter.

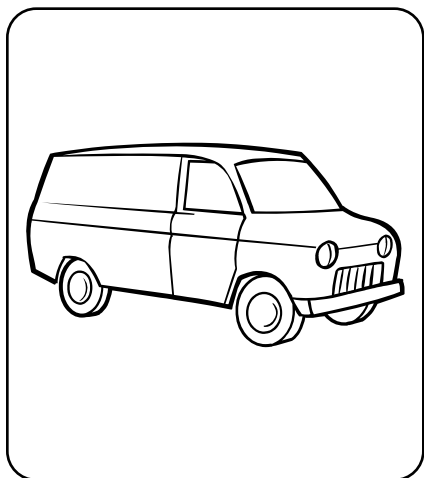

\_\_\_ a n



h \_\_\_ g



\_\_\_ a m

**Directions:** Cut out the pictures. Sort them by beginning sound. Then paste them in the boxes.

**b**

--	--	--	--

**g**

--	--	--	--

**j**

--	--	--	--



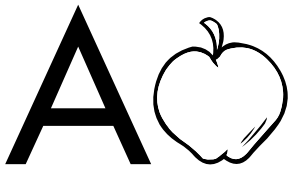

## Identifying Sound-Letter Associations

**Directions:** Read the word by sounding out each letter. Draw a picture to match the word. **Pictures will vary.**

bag

dog

cup

**Directions:** Look at the pictures. Say the name of each picture aloud. Then write the missing letter.

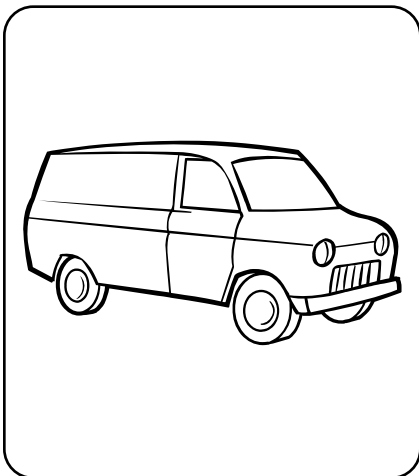

   v a n



h    u    g



   j a m

**Directions:** Cut out the pictures. Sort them by beginning sound. Then paste them in the boxes.

b

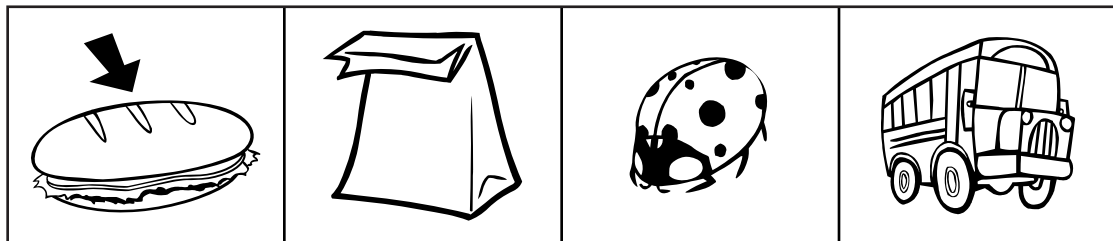

g

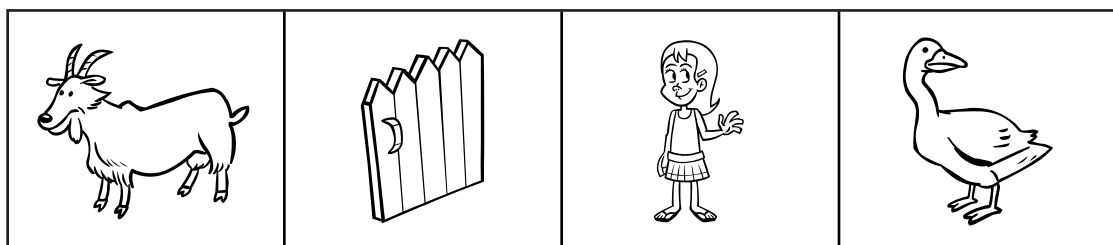

j

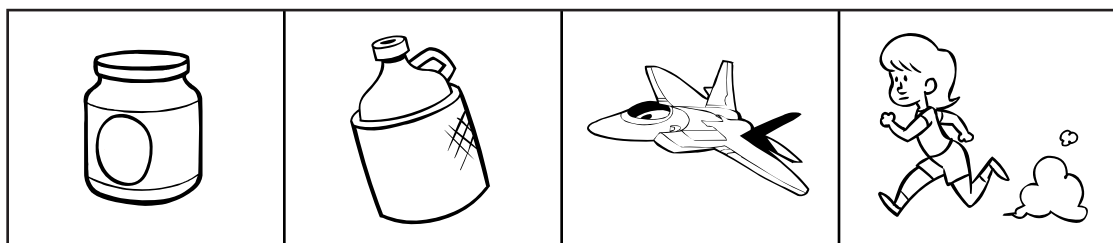

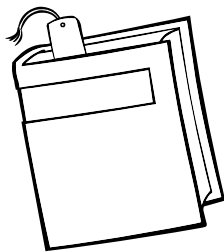

## Understanding Multiple-Meaning Words

**Directions:** Cut out each picture. Then paste the picture above the word with the same meaning.

--	--

top

--	--

bat

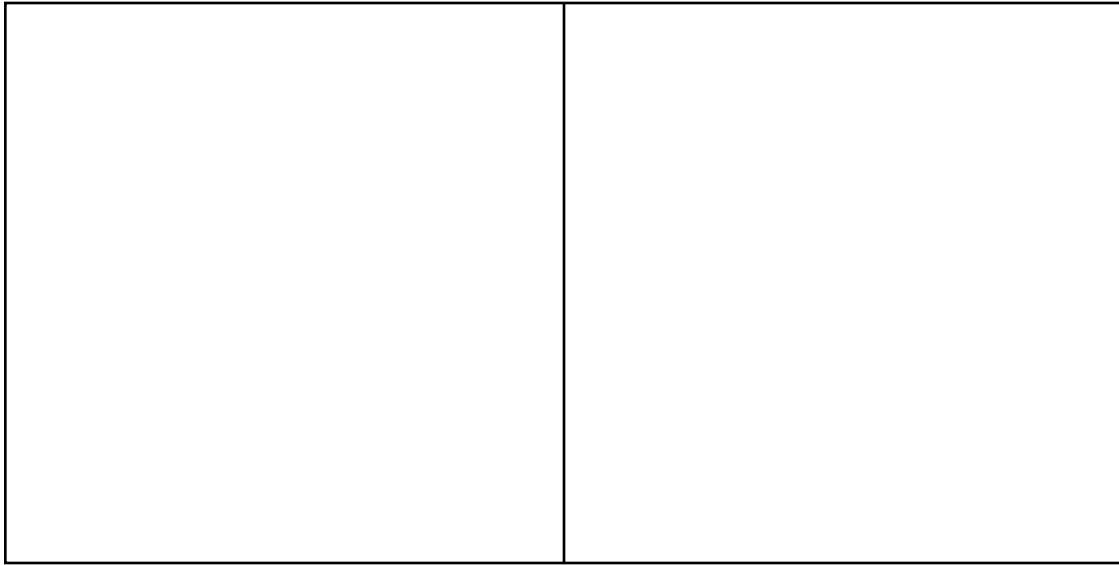

bit



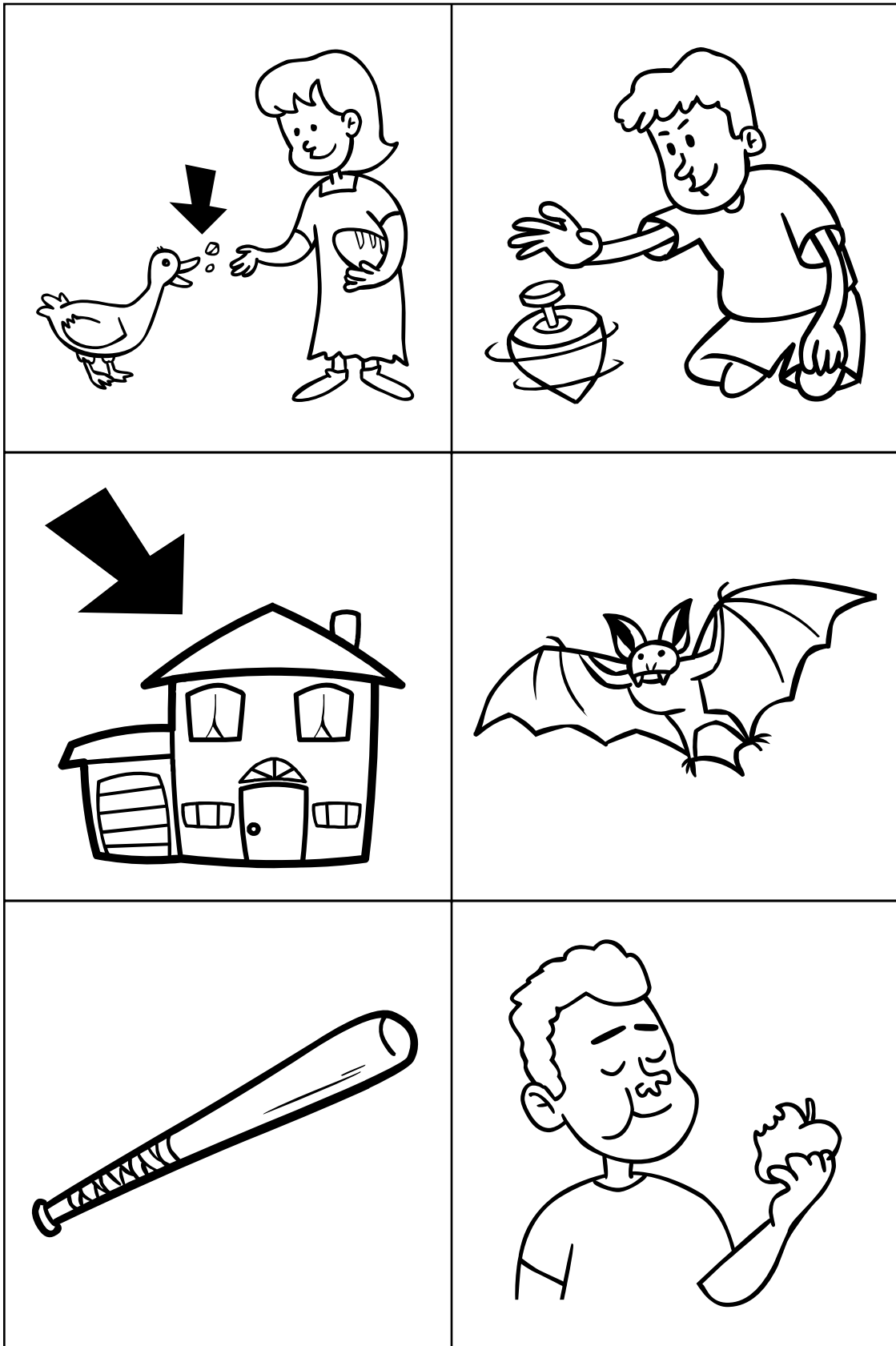

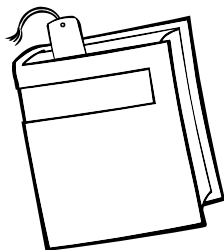

## Understanding Multiple-Meaning Words

**Directions:** Cut out each picture. Then paste the picture above the word with the same meaning.

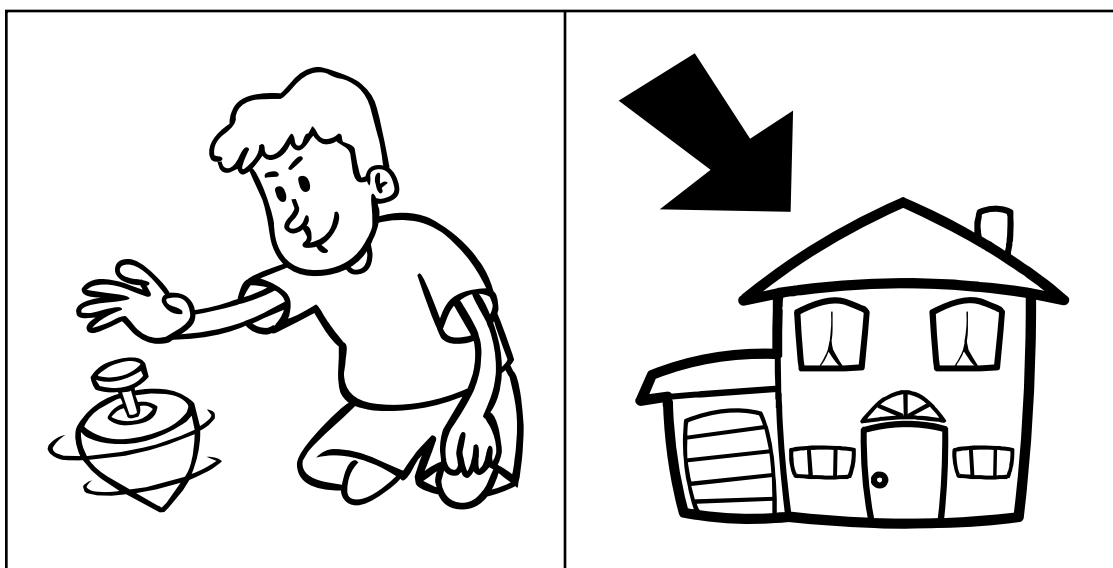

top

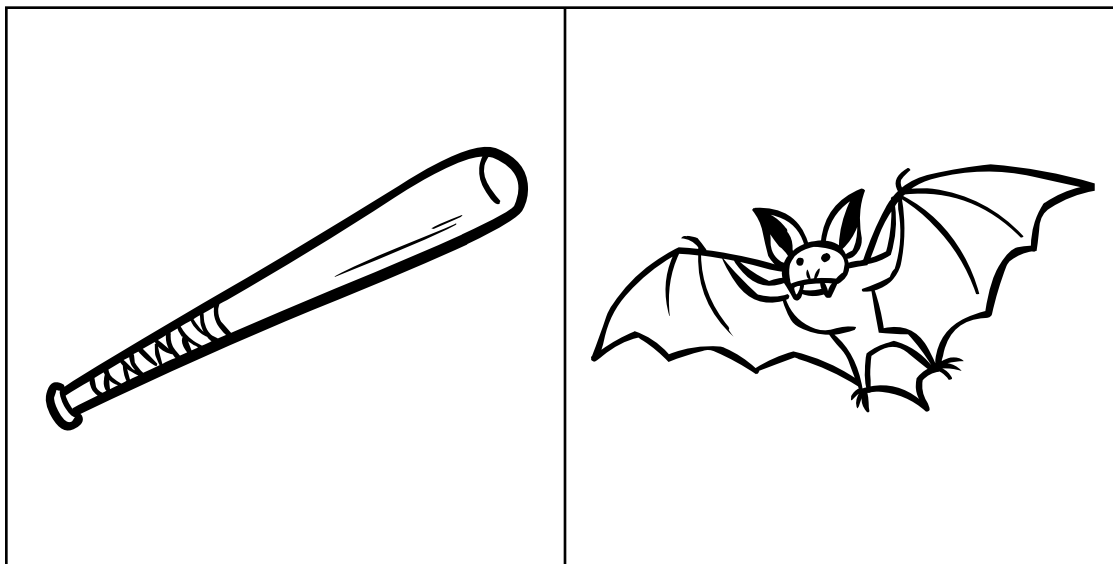

bat

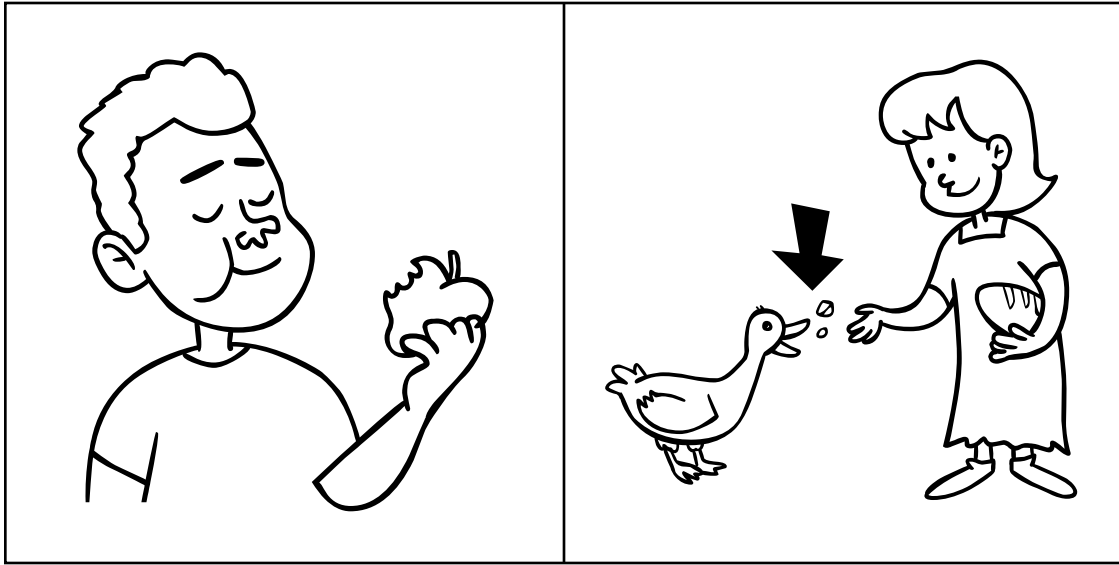

bit

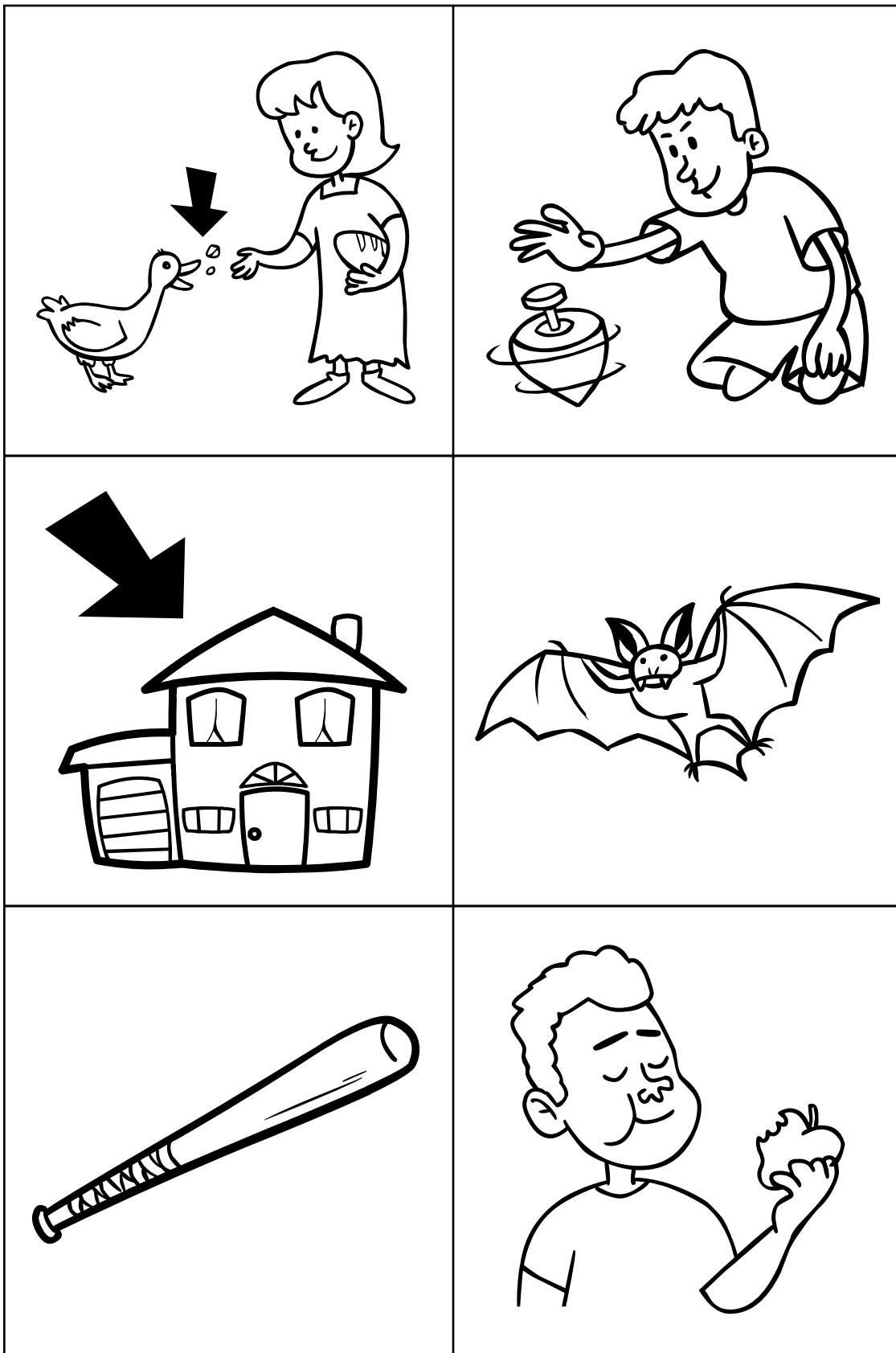

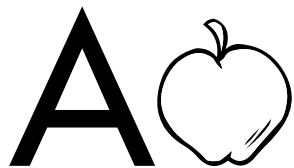

## Reading High Frequency Words

**Directions:** Draw pictures to match the words.



That is a gray circle.



That is a brown oval.

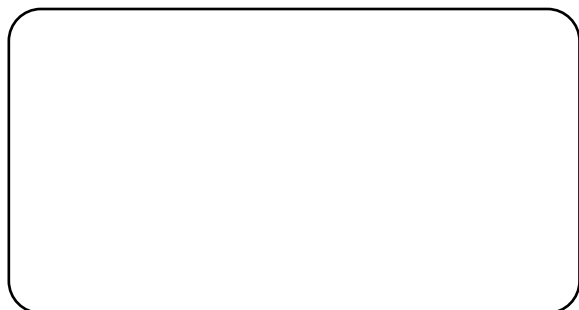

That is a pink square.

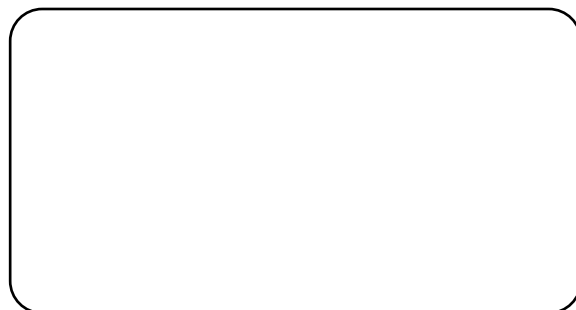

That is a yellow star.

**Directions:** Cut out the pictures. Then paste them in the correct order.

1.

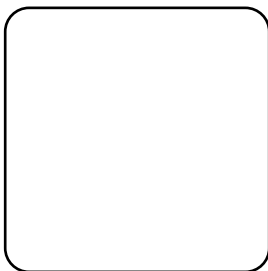

2.

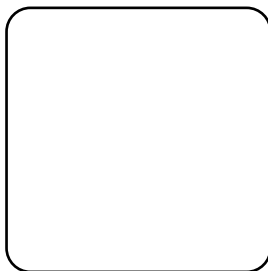

3.

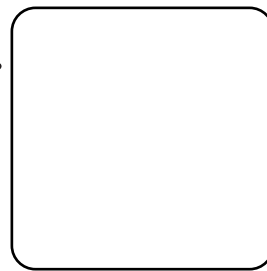

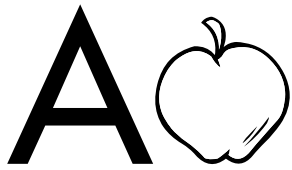

## Reading High Frequency Words

**Directions:** Draw pictures to match the words.

gray

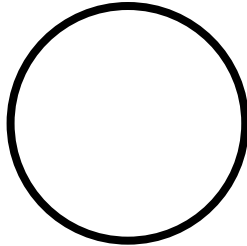

That is a gray circle.

brown

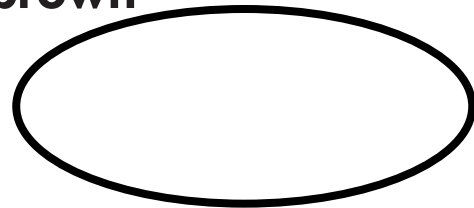

That is a brown oval.

pink

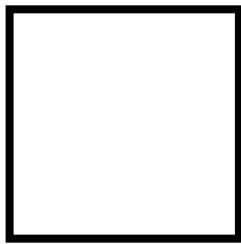

That is a pink square.

yellow

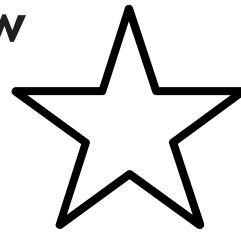

That is a yellow star.

**Directions:** Cut out the pictures. Then paste them in the correct order.

1.



2.



3.

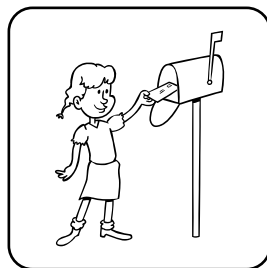
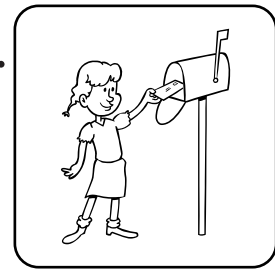

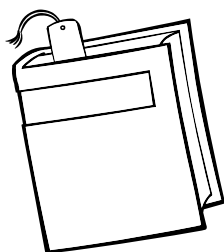

## Reading Fluently

**Directions:** Cut out the pages and put them in order. Staple the pages together. Then sing the story to the tune of “Twinkle, Twinkle, Little Star.”

**Sing about  
Letters**

Wqetg  
Sacum

Name \_\_\_\_\_

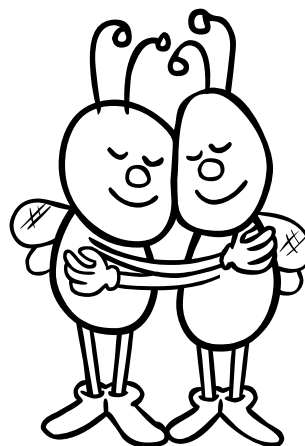

B-u-g. That is bug.  
H-u-g. That is hug.

1



P-i-g. That is pig.  
J-i-g. That is jig.

2



R-u-n. That is run.  
F-u-n. That is fun.

3

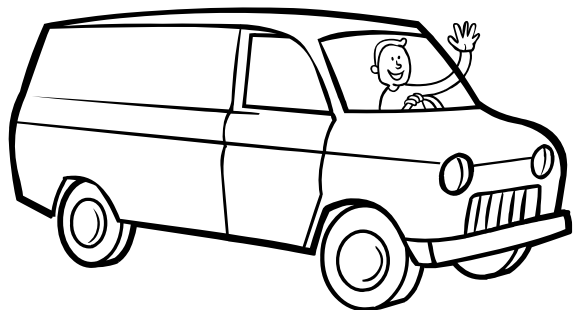

V-a-n. That is van.  
M-a-n. That is man.

4



B-a-g. That is bag.  
T-a-g. That is tag.

5



D-o-g. That is dog.  
J-o-g. That is jog.

6

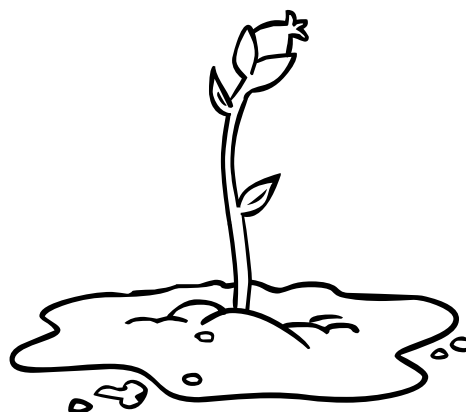

M-u-d. That is mud.  
B-u-d. That is bud.

7



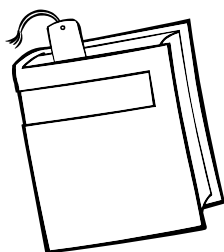

## Reading Fluently

**Directions:** Cut out the pages and put them in order. Staple the pages together. Then sing the story to the tune of “Twinkle, Twinkle, Little Star.”

**Sing about  
Letters**

Wqetg  
Sacum

Name \_\_\_\_\_

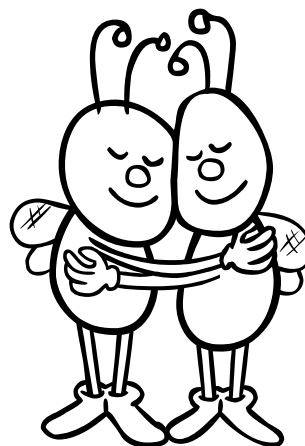

B-u-g. That is bug.  
H-u-g. That is hug.

1



P-i-g. That is pig.  
J-i-g. That is jig.

2



R-u-n. That is run.  
F-u-n. That is fun.

3

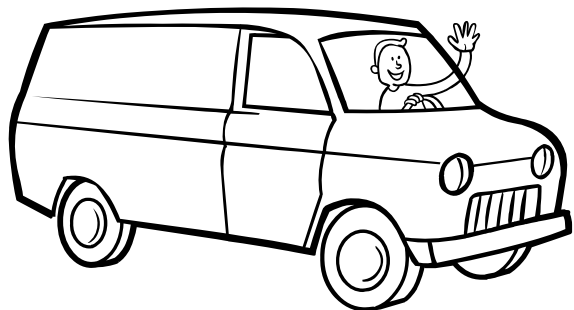

V-a-n. That is van.  
M-a-n. That is man.

4



B-a-g. That is bag.  
T-a-g. That is tag.

5



D-o-g. That is dog.  
J-o-g. That is jog.

6

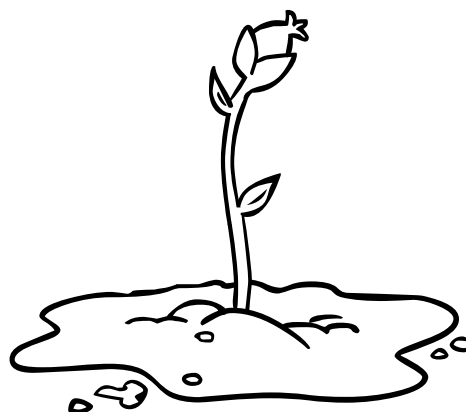

M-u-d. That is mud.  
B-u-d. That is bud.

7

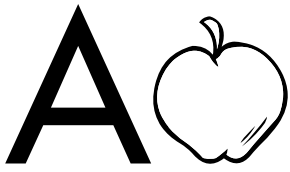

## Identifying Sound-Letter Associations

**Directions:** Look at the pictures. Say the name of each picture aloud. Then write the missing letter.

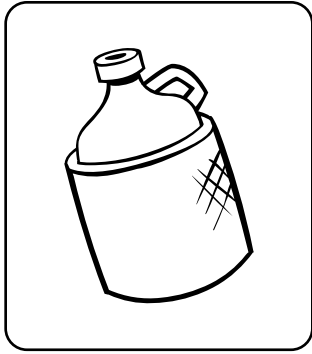

j u \_\_\_\_

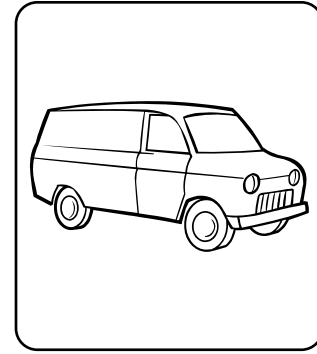

\_\_\_\_ a n

**Directions:** Draw a story. Show the beginning, middle, and end.

1.

2.

3.

**Directions:** Read the sentences. Then circle the words **is**, **you**, and **that**.

That is a top.

That is a fan.

You are a kid.

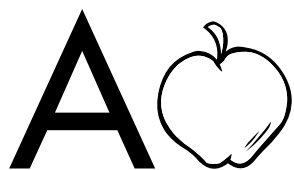

## Identifying Sound-Letter Associations

**Directions:** Look at the pictures. Say the name of each picture aloud. Then write the missing letter.

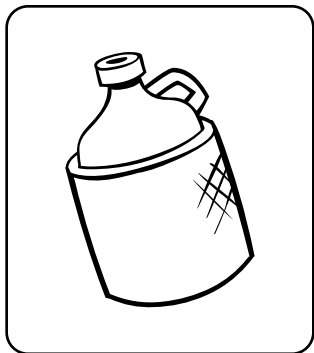

j u g

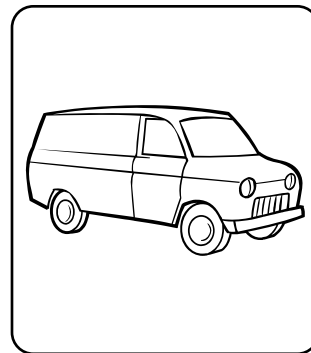

v a n

**Directions:** Draw a story. Show the beginning, middle, and end.

**Pictures will vary.**

1.

2.

3.

**Directions:** Read the sentences. Then circle the words **is**, **you**, and **that**.

That **is** a top.

That **is** a fan.

**You** are a kid.

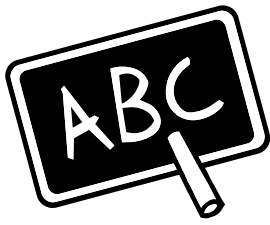

## Identifying Sound-Letter Association

**Directions:** For each row, say the name of each picture aloud. Then color two pictures that begin with the same sound as the letter in the box.

**Ee**

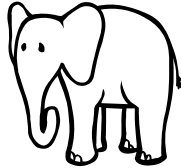
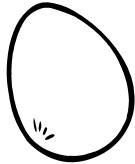

**Zz**

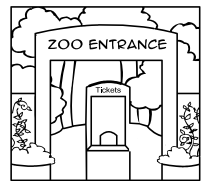
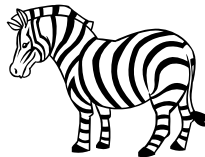
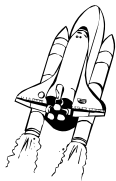

**Ww**

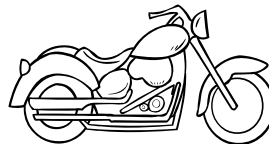

**Directions:** Look at each picture. Say the name of the picture aloud. Then circle the pictures that end with the same sound as fox.

**Xx**

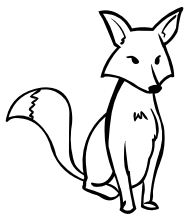

fox

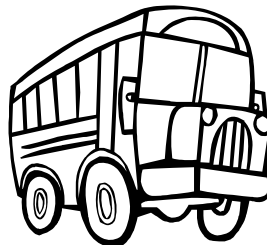
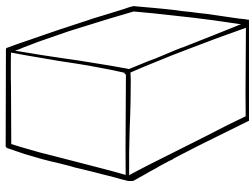

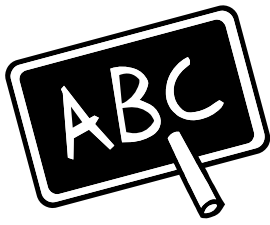

## Identifying Sound-Letter Association

**Directions:** For each row, say the name of each picture aloud. Then color two pictures that begin with the same sound as the letter in the box.

**Ee**

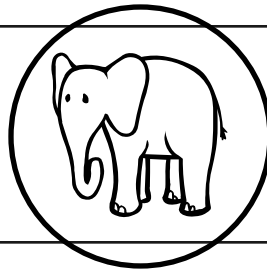
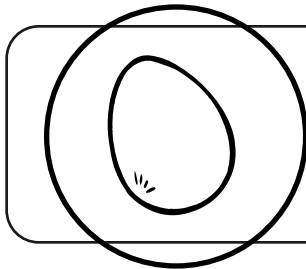

**Zz**

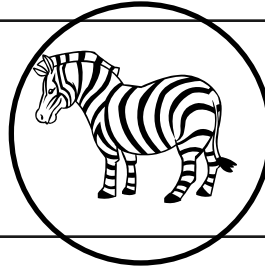

**Ww**

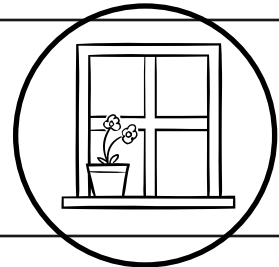
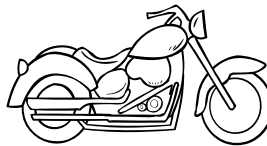
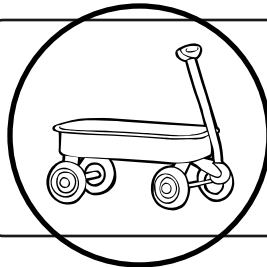

**Directions:** Look at each picture. Say the name of the picture aloud. Then circle the pictures that end with the same sound as fox.

**Xx**

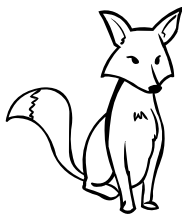

fox

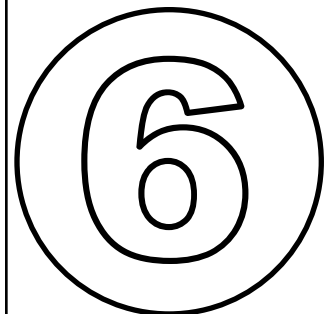
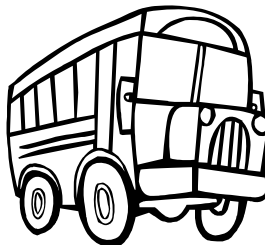
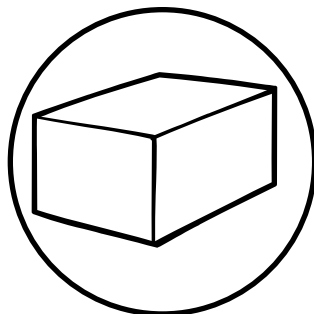

## aeiou Understanding Positional Words

Directions: Follow the directions below the picture.

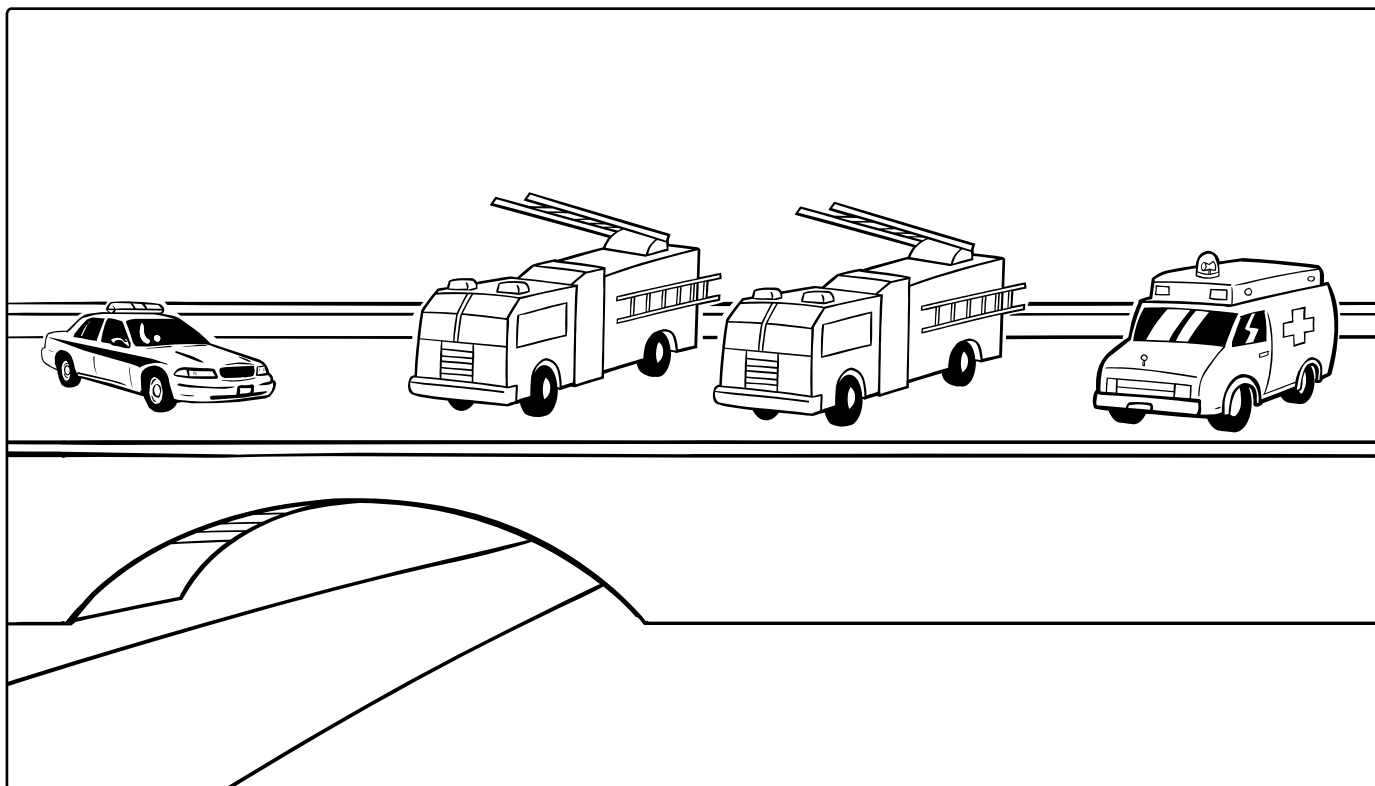

1. Draw an **X** beside the  .

2. Draw a **△** between the   .

3. Draw a circle around the  .

4. Draw a  above the  .

5. Draw a  under the  .

**Directions:** Cut out the pictures. Sort them into groups. Then paste them in the boxes.

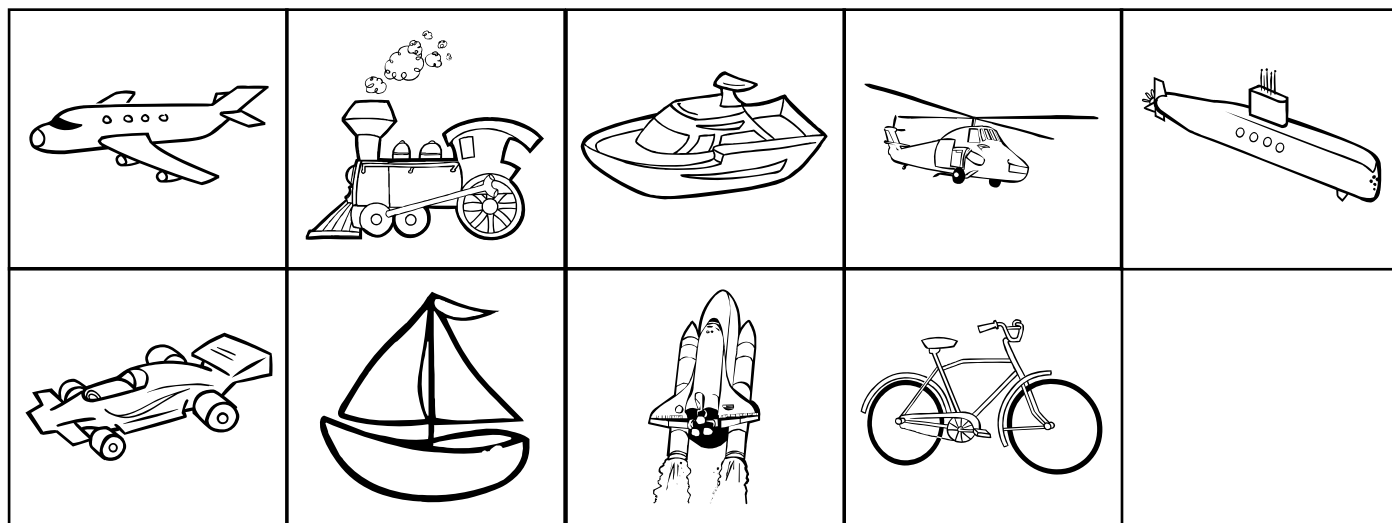
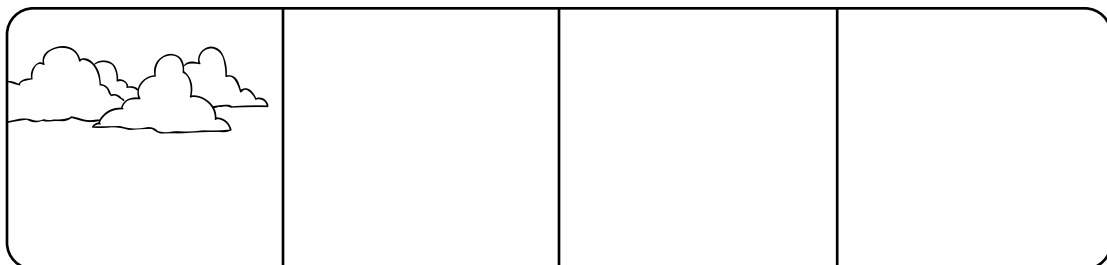
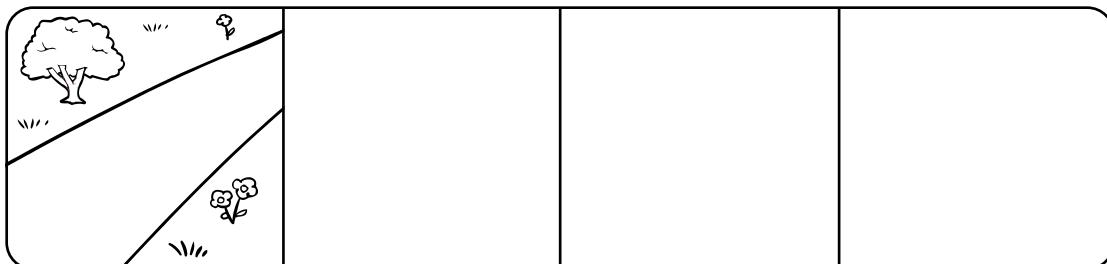
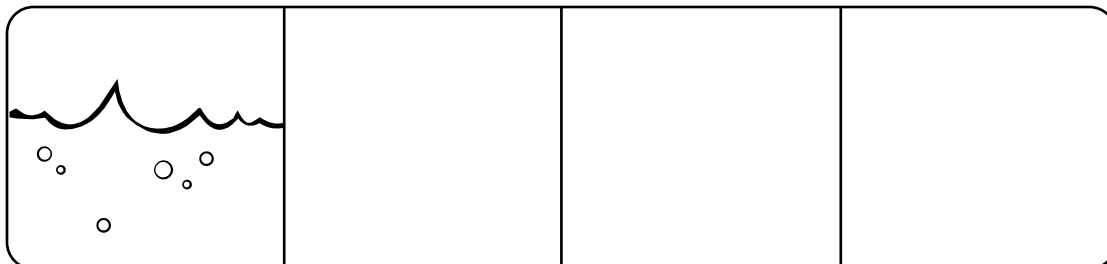



**Directions:** Cut out the puzzle. Say each sound as you build the puzzle. Blend the sounds together. Then read the word.

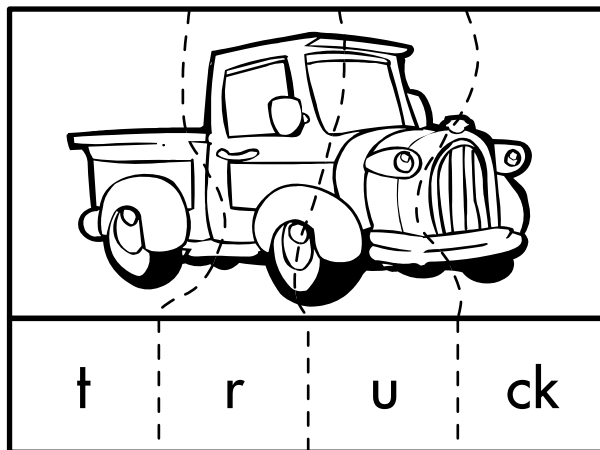
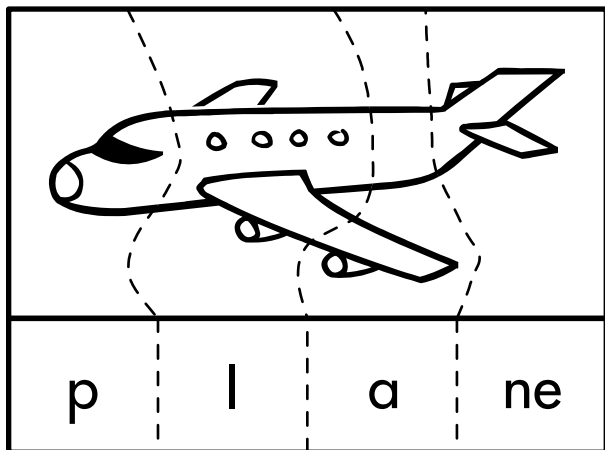
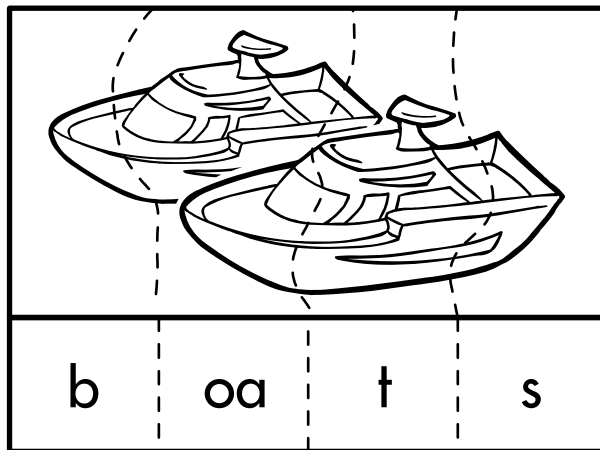
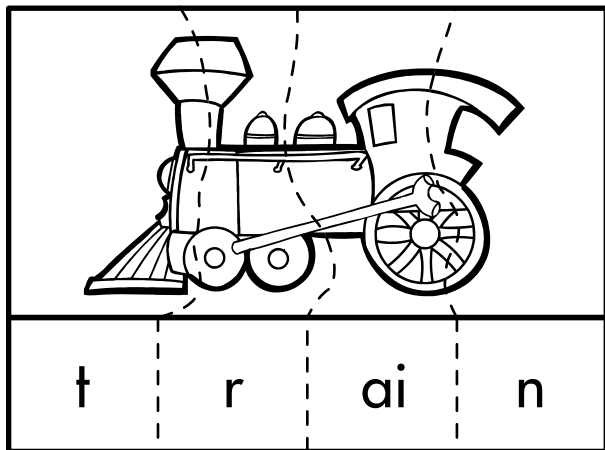

## aeiou

### Understanding Positional Words

Directions: Follow the directions below the picture.

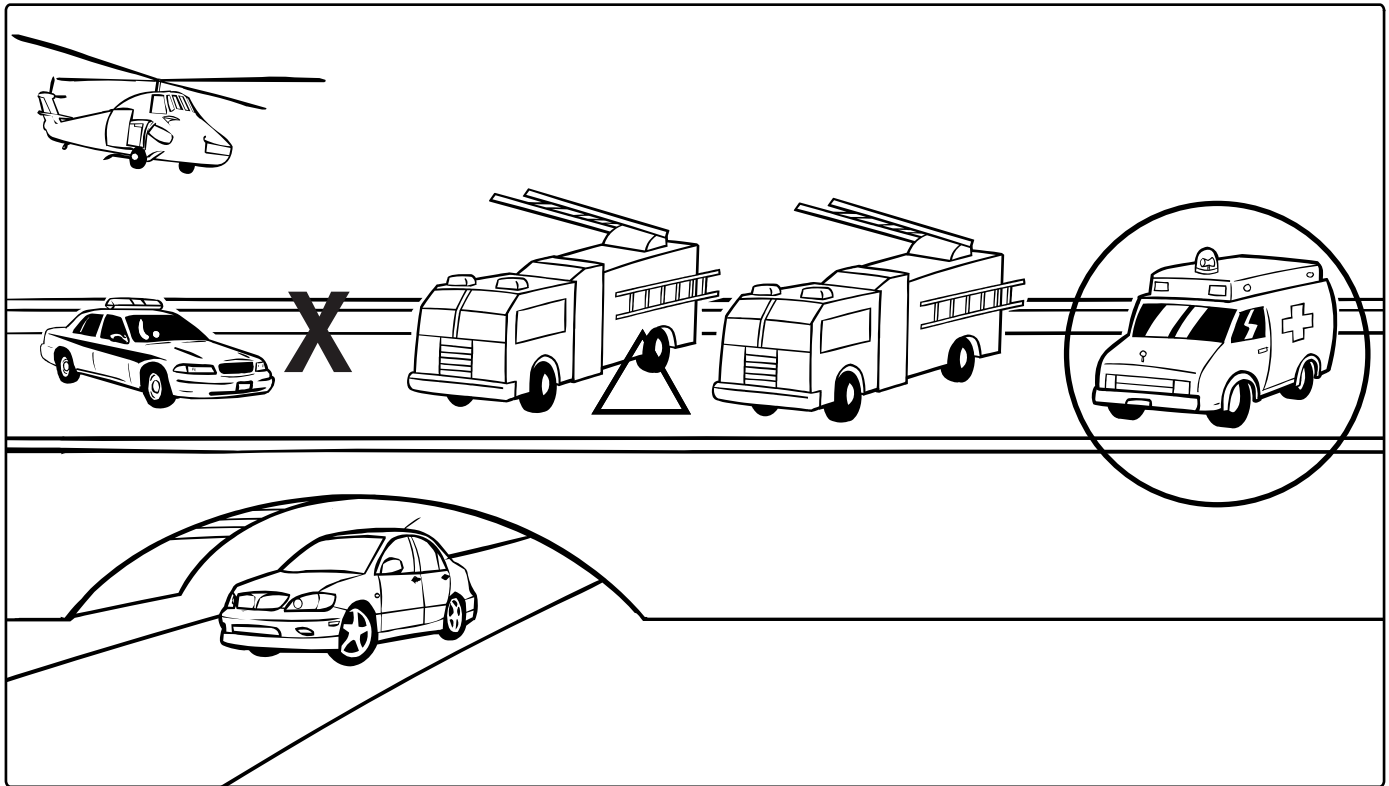

1. Draw an **X** beside the  .

2. Draw a **△** between the   .

3. Draw a circle around the  .

4. Draw a  above the  .

5. Draw a  under the  .

**Directions:** Cut out the pictures. Sort them into groups. Then paste them in the boxes.

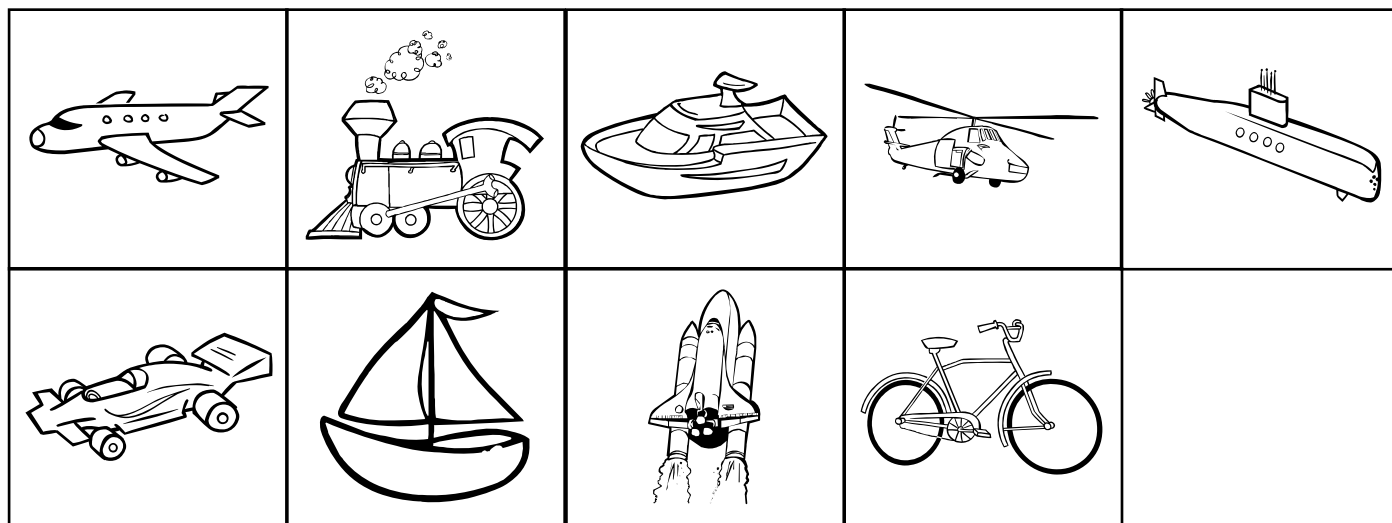
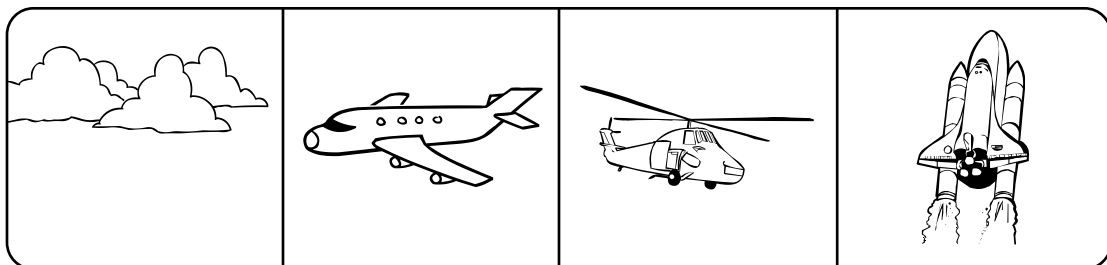
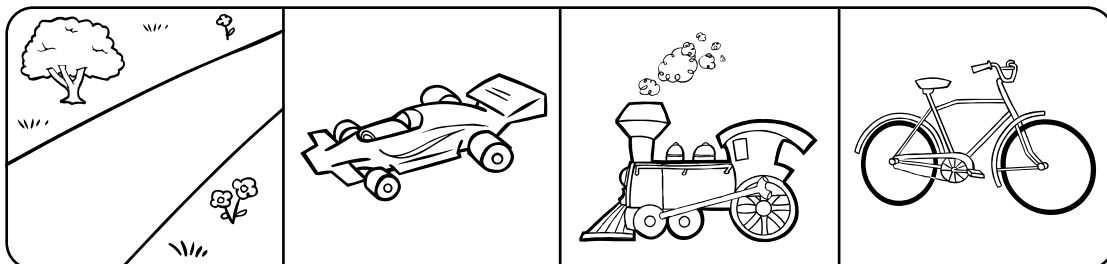
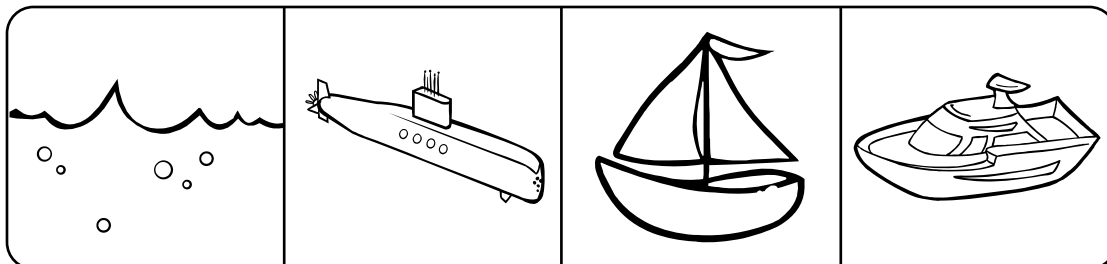

**Directions:** Cut out the puzzle. Say each sound as you build the puzzle. Blend the sounds together. Then read the word.

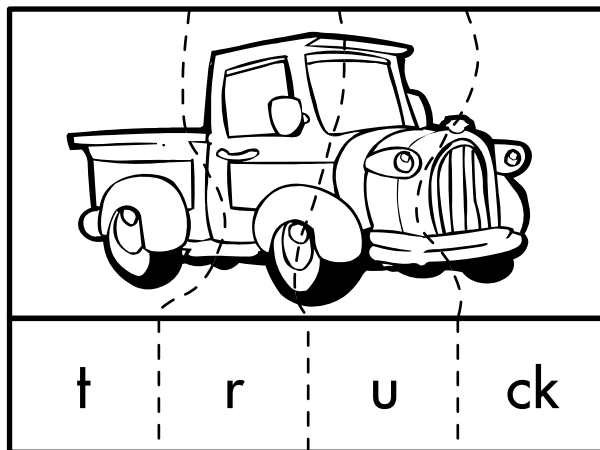
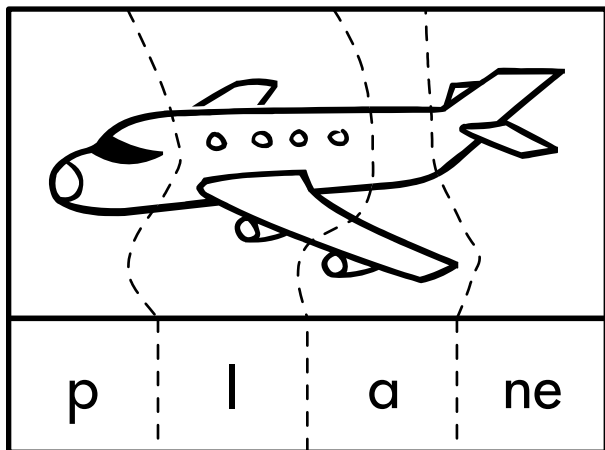
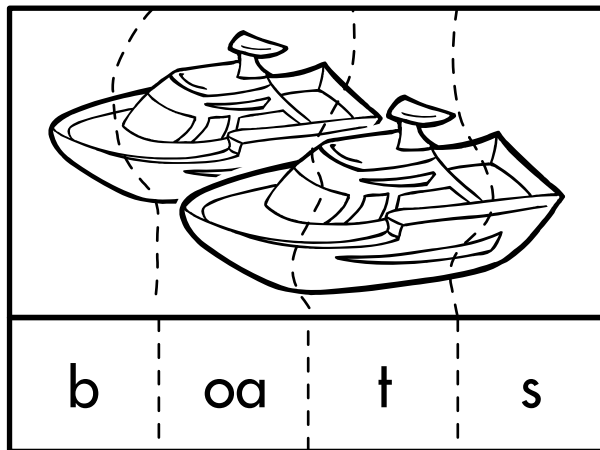
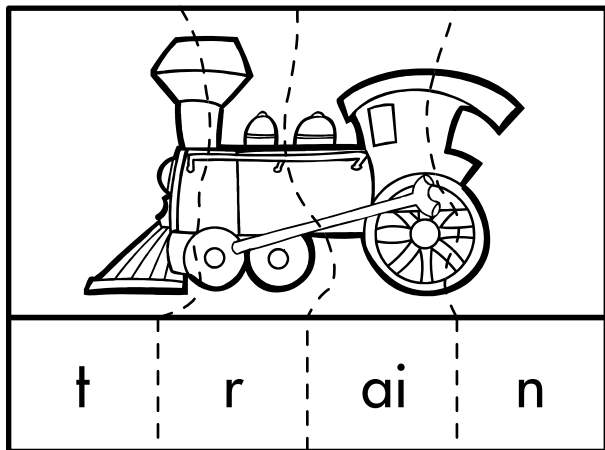

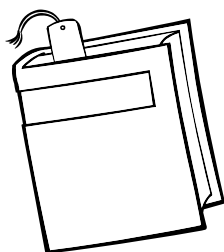

## Retell a Story: Character

**Directions:** Cut out the pages and put them in order. Staple the pages together. Then read the story and answer the questions.

### On the Sailboat

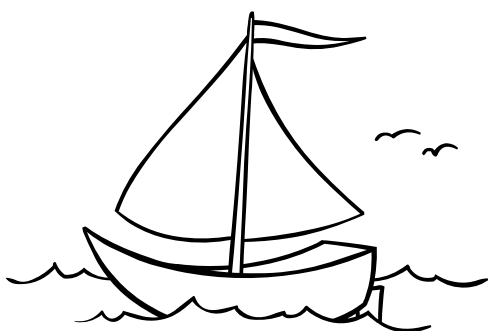

by René Holden

Name \_\_\_\_\_



Will is on a sailboat.  
It is in the water.

1

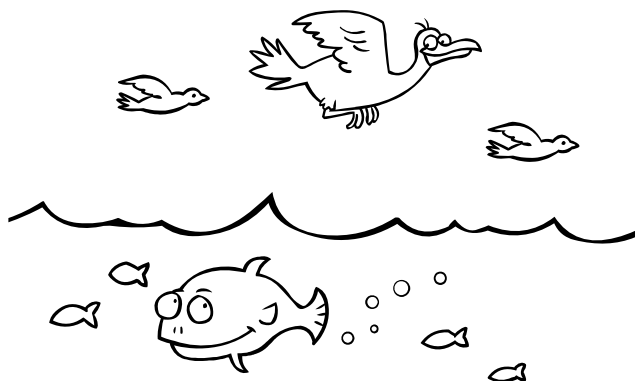

Will sees birds.  
Will sees fish.

2



Will sees a big ship. He  
sees a dog on the ship.

3



Will waves at the dog.  
Will likes the sailboat a lot.

4

Who is this story about?

---

---

---

5

What is the story about?

---

---

---

6

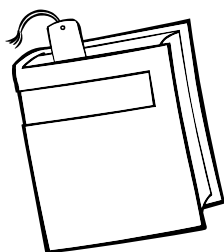

## Retell a Story: Character

**Directions:** Cut out the pages and put them in order. Staple the pages together. Then read the story and answer the questions.

### On the Sailboat

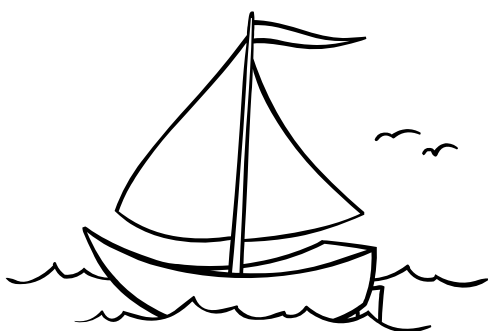

by René Holden

Name \_\_\_\_\_



Will is on a sailboat.  
It is in the water.

1

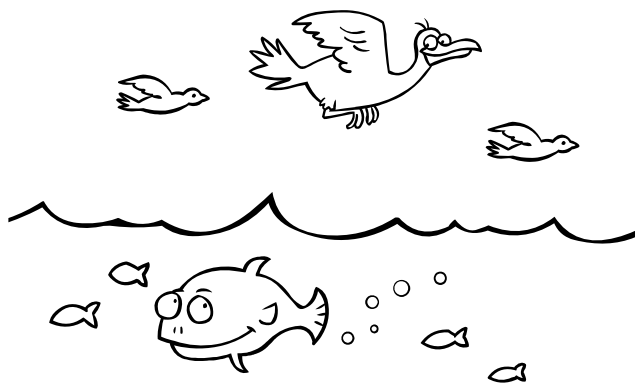

Will sees birds.  
Will sees fish.

2



Will sees a big ship. He  
sees a dog on the ship.

3



Will waves at the dog.  
Will likes the sailboat a lot.

4

Who is this story about?

Pictures  
will vary.

\_\_\_\_\_

----- **Will** -----

\_\_\_\_\_

5

What is the story about?

Pictures  
will vary.

\_\_\_\_\_

a boy on a sailboat

6



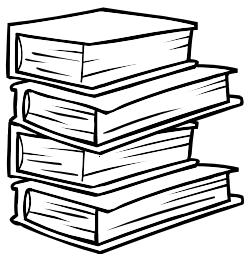

## Identifying Sound-Letter Association for Alphabet

**Directions:** Look at each picture. Circle the letters that stand for the beginning sound. Then write the **qu** or **y** on the line to complete the word.

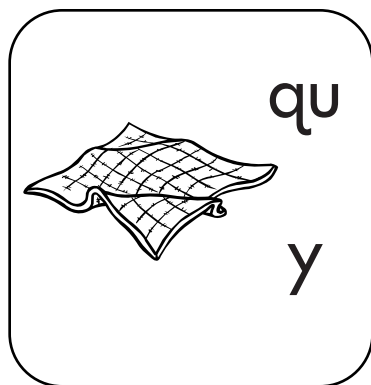

\_\_\_\_\_ilt

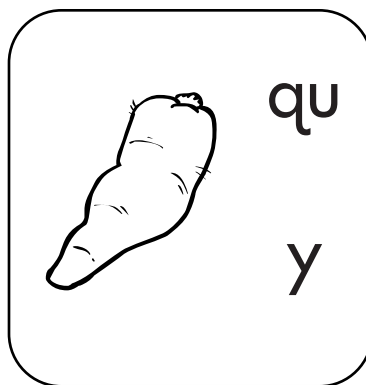

\_\_\_\_\_am



\_\_\_\_\_een

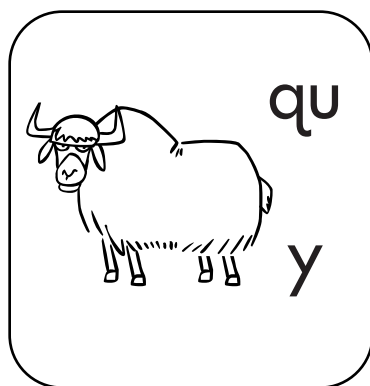

\_\_\_\_\_ak

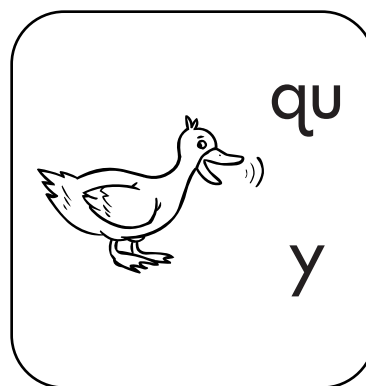

\_\_\_\_\_ack

**Directions:** Cut out the pictures. Sort them into groups. Then paste them in the boxes.

Transportation for a Job				

Air Transportation		

Everyday Transportation			

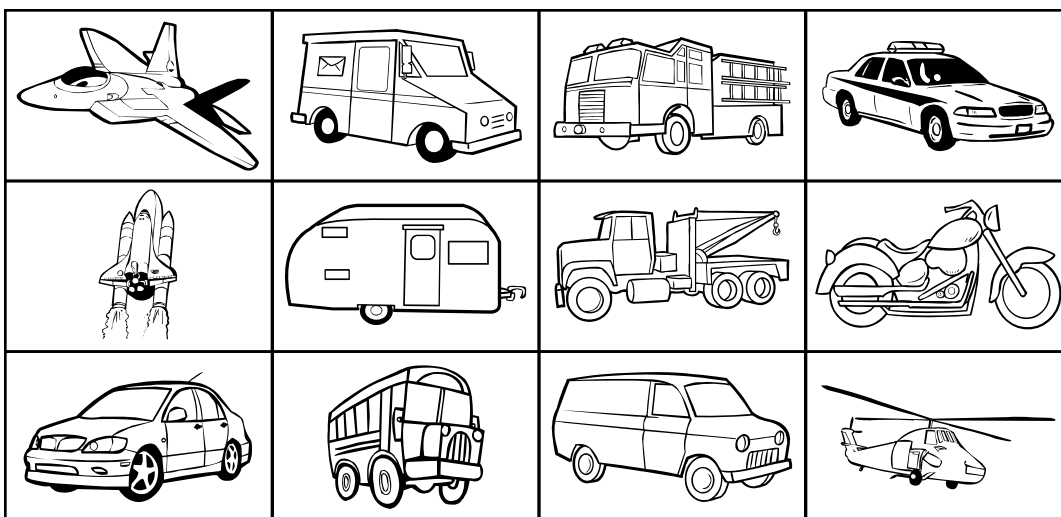

**Directions:** Cut out the puzzle. Say each sound as you build the puzzle. Blend the sounds together. Then read the word aloud.

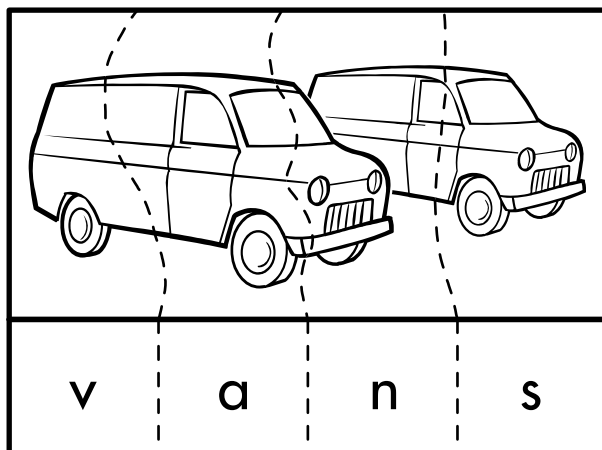
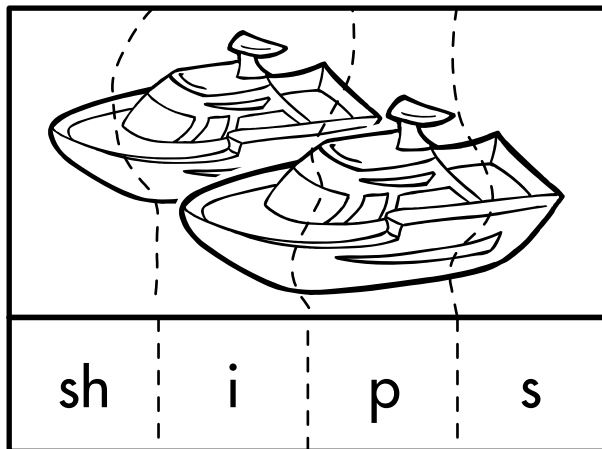



## Identifying Sound-Letter Association for Alphabet

**Directions:** Look at each picture. Circle the letters that stand for the beginning sound. Then write the **qu** or **y** on the line to complete the word.

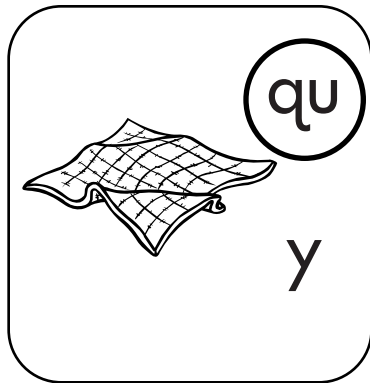

quilt

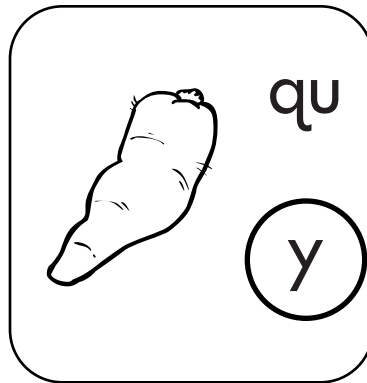

yam



queen

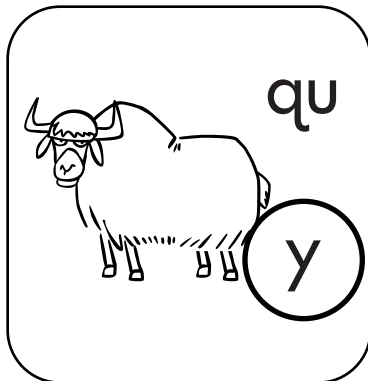



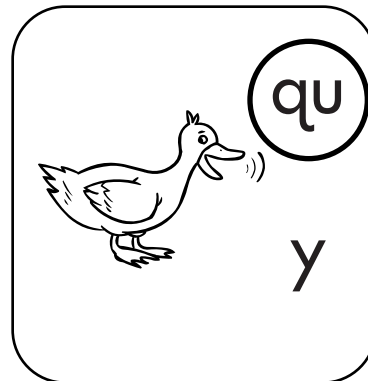



yak







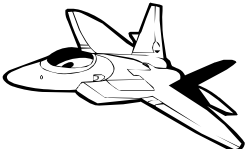



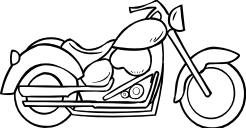
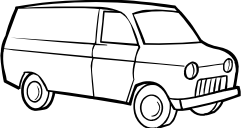
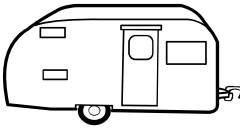

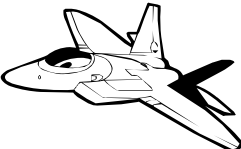
quack

**Directions:** Cut out the pictures. Sort them into groups. Then paste them in the boxes.

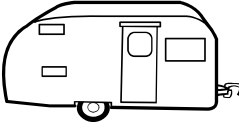
<b>Transportation for a Job</b>				
				

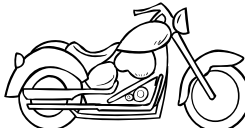
<b>Air Transportation</b>		
		

<b>Everyday Transportation</b>			
			

**Directions:** Cut out the puzzle. Say each sound as you build the puzzle. Blend the sounds together. Then read the word aloud.



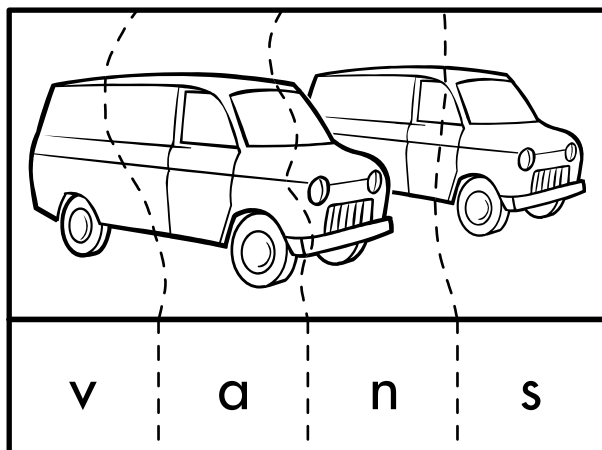
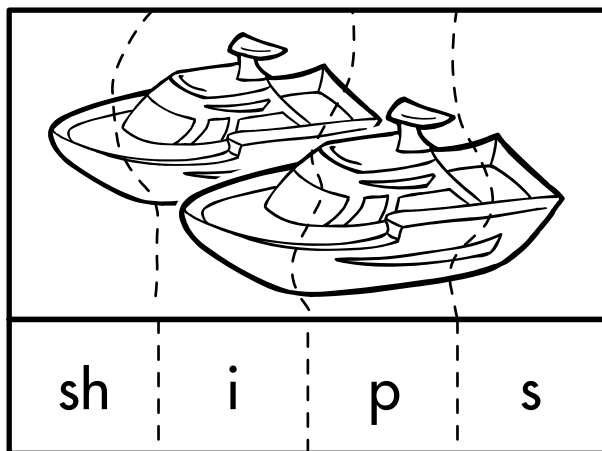

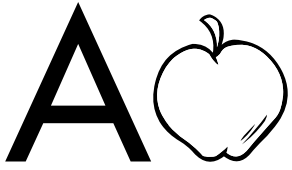
## Reading High Frequency Words

**Directions:** Read the poem. Then circle the words **it**, **he**, and **was**.

### Tag

Sam and Dan play tag.

Sam was it.

He tagged Dan.

Dan was it.

He tagged Sam.

They had fun.

**Directions:** Draw pictures to show what happens at the beginning, middle, and end of the poem.

**Beginning**

A large, empty rounded rectangular box with a thin black border, intended for drawing a picture of the beginning of the poem.

**Middle**

A large, empty rounded rectangular box with a thin black border, intended for drawing a picture of the middle of the poem.

**End**

A large, empty rounded rectangular box with a thin black border, intended for drawing a picture of the end of the poem.

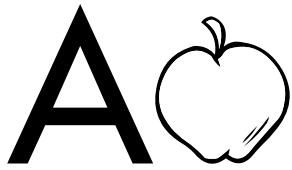

## Reading High Frequency Words

**Directions:** Read the poem. Then circle the words **it**, **he**, and **was**.

### Tag

Sam and Dan play tag.

Sam was it.

He tagged Dan.

Dan was it.

He tagged Sam.

They had fun.

**Directions:** Draw pictures to show what happens at the beginning, middle, and end of the poem.

### Beginning

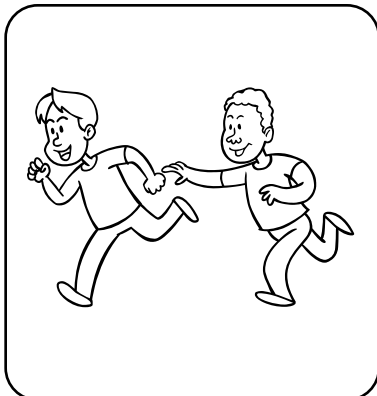

### Middle

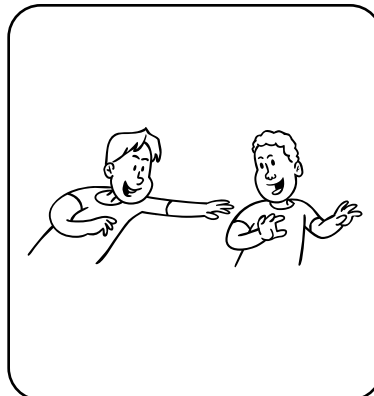

### End

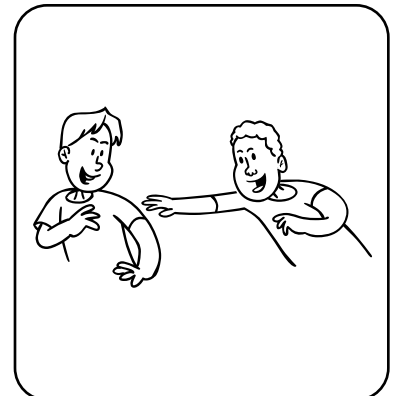





## Identifying Sound-Letter Association and Reading High Frequency Words

**Directions:** For each row, circle the picture that begins with the same sound as the letter in the box.

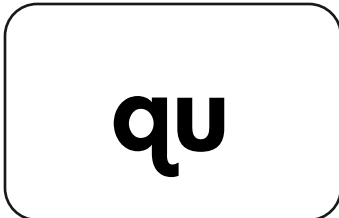
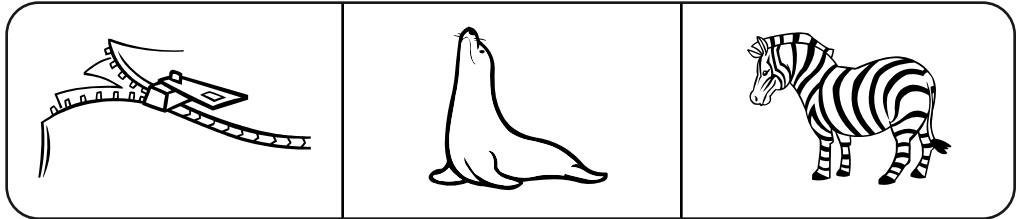
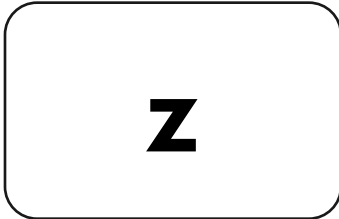

**Directions:** Look at the picture. Draw an **X** between the cars. Draw a **O** above the bike.

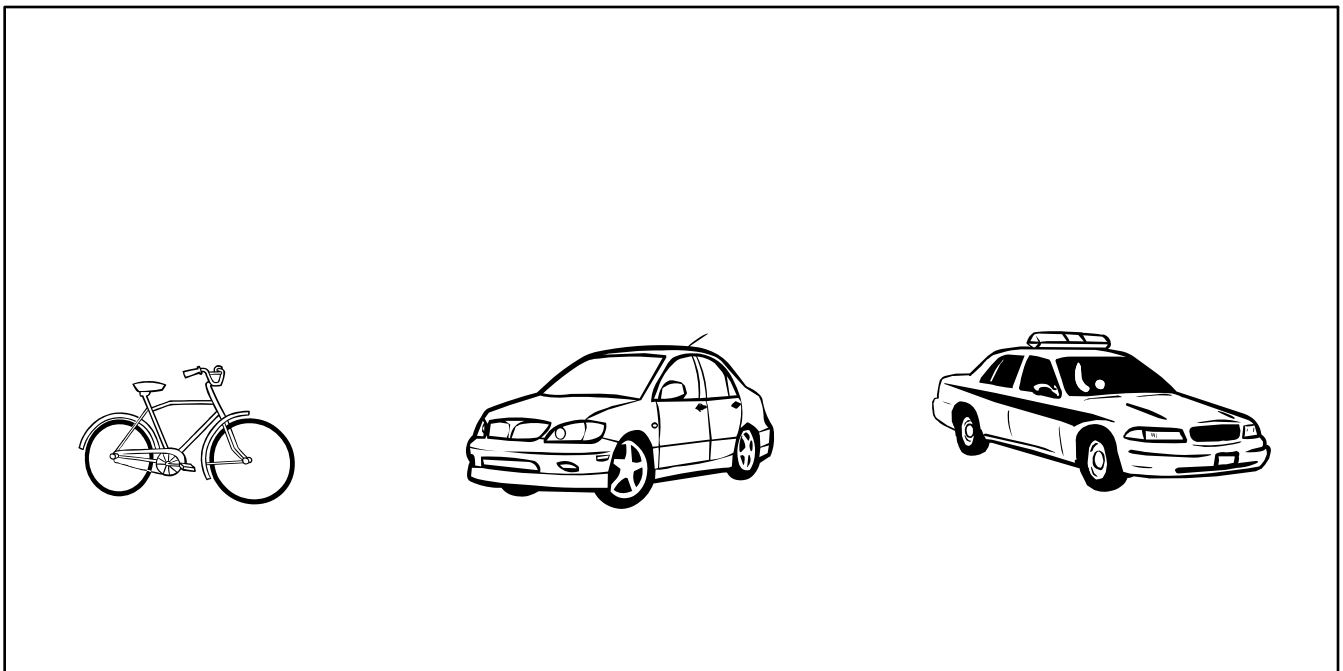

**Directions:** Read the story. Then draw pictures to answer the questions.

## In the Box



**Bob**

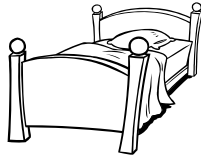

**bed**

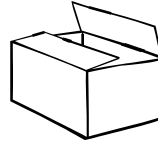

**box**



**Mom**

Bob is on his bed. He has a box.

He has a  in the box.  
fire engine

He has a  in the box.  
police car

He has an  in the box.  
ambulance

Bob plays with his  on his bed.  
toys

Mom yells, “Let’s go, Bob!”

Bob puts the  in the box.  
fire engine

He puts the  in the box.  
police car

“Yes, Mom, I put the  in the box. Let’s go!”  
toys

**Beginning**

**Middle**

**End**



## Identifying Sound-Letter Association and Reading High Frequency Words

**Directions:** For each row, circle the picture that begins with the same sound as the letter in the box.

**z**

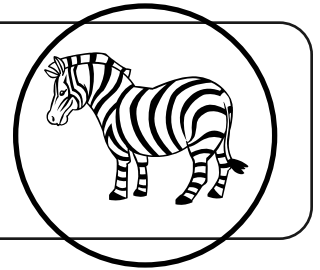
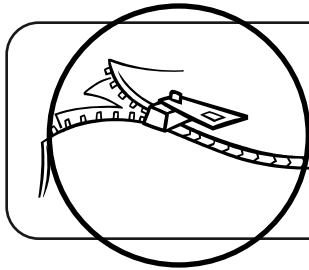

**qu**

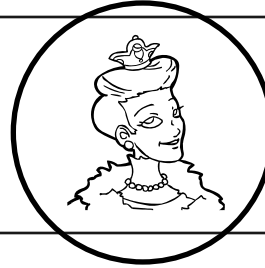
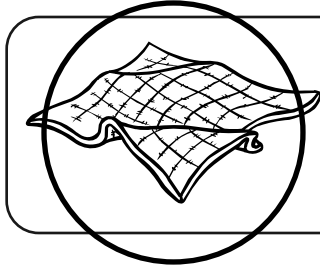

**Directions:** Look at the picture. Draw an **X** between the cars. Draw a  above the bike.

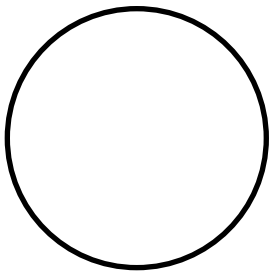

**X**



**Directions:** Read the story. Then draw pictures to answer the questions.

## In the Box



**Bob**

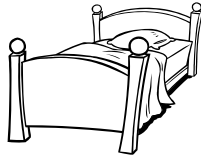

**bed**

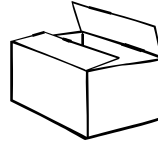

**box**



**Mom**

Bob is on his bed. He has a box.

He has a  in the box.  
fire engine

He has a  in the box.  
police car

He has an  in the box.  
ambulance

Bob plays with his  on his bed.  
toys

Mom yells, “Let’s go, Bob!”

Bob puts the  in the box.  
fire engine

He puts the  in the box.  
police car

“Yes, Mom, I put the  in the box. Let’s go!”  
toys

**Beginning**

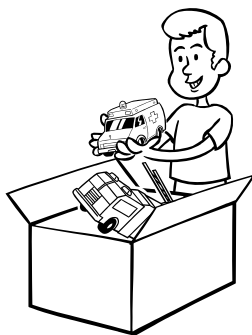

**Middle**

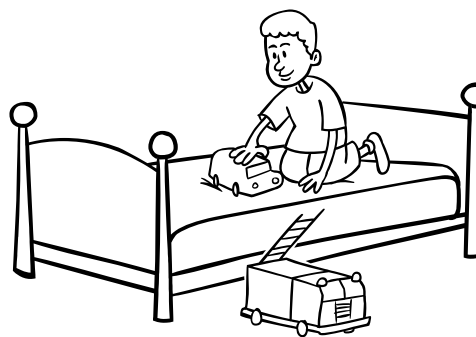

**End**



# aeiou Identifying Possessives and Pronouns

**Directions:** Read the sentences. Underline the person, place, or thing that has possession. Then draw a ○ around the '.

1. That is Dad's  .  
dog

2. Pam's  is big.  
ball

3. The cat's  is soft.  
bed

4. Sam was on Dad's  .  
bike

5. My mom's  is red.  
dress

6. Nan's  is tall.  
sister

7. The park's  is fun!  
slide

8. Tom's  is new.  
kite

9. The bird's  is in the tree.  
nest

10. Fred's  are blue.  
shoes



## aeiou Identifying Possessives and Pronouns

**Directions:** Read the sentences. Underline the person, place, or thing that has possession. Then draw a ○ around the '.

1. That is Dad's  .  
dog

2. Pam's  is big.  
ball

3. The cat's  is soft.  
bed

4. Sam was on Dad's  .  
bike

5. My mom's  is red.  
dress

6. Nan's  is tall.  
sister

7. The park's  is fun!  
slide

8. Tom's  is new.  
kite

9. The bird's  is in the tree.  
nest

10. Fred's  are blue.  
shoes

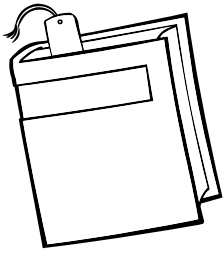

## Reading High Frequency Words

**Directions:** Read the poem. Look for the words **for**, **on** and **are**. Draw a ○ around the word **for**. Draw a □ around the word **on**. Underline the word **are**.

### Little Frog

The little   
frog

Sits on a   
log

Looking for her dad.

She sees a   
snake

On a  by the   
rock lake

“You are not my dad!

She spots a   
bug

Asleep on a  .  
rug

“You are not my dad!”

She sees a  .  
fox

On top of a  .  
box

“You are not my dad!”

The little  .  
frog

Sits on a  .  
log

Wanting to jump in the sea.

“Croak!” yells the  .  
toad

“Don’t hit the  !  
road

You are looking for me!”

**Directions:** Draw the answer to the questions.

**Who?**

**What?**

**Where?**

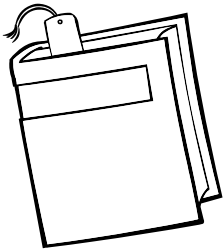

## Reading High Frequency Words

**Directions:** Read the poem. Look for the words **for**, **on** and **are**. Draw a ○ around the word **for**. Draw a □ around the word **on**. Underline the word **are**.

### Little Frog

The little   
frog

Sits  on a   
log

Looking  for her dad.

She sees a   
snake

On a  by the   
rock lake

“You are not my dad!

She spots a   
bug

Asleep **on** a  .  
rug

“You are not my dad!”

She sees a  .  
fox

**On** top of a  .  
box

“You are not my dad!”

The little  .  
frog

Sits **on** a  .  
log

Wanting to jump in the sea.

“Croak!” yells the  .  
toad

“Don’t hit the  !  
road

You are looking **(for)** me!”

**Directions:** Draw the answer to the questions.

**Who?**

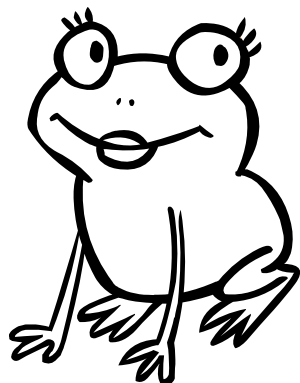

**What?**

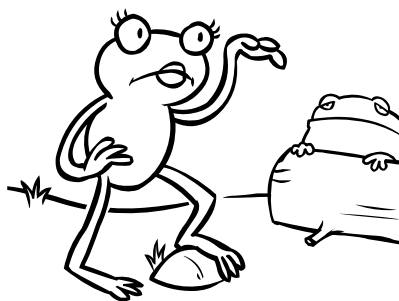

**Where?**

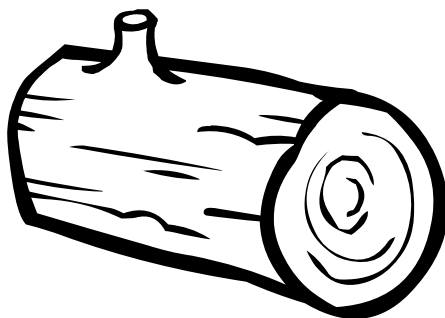



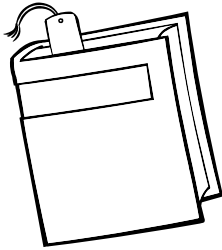

## Retelling a Story

**Directions:** Cut out the pages. Put them in order. Staple the pages together. Then read the story and answer the questions.

### Turtle's Party

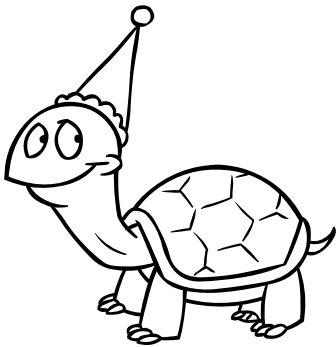

by Kathryn LaComb

Name \_\_\_\_\_



Turtle is having a party  
at his house.

1



"Where is Turtle's house?"  
Squirrel asks Beaver.

2



"Where is Turtle's house?"  
Beaver asks Frog.

3

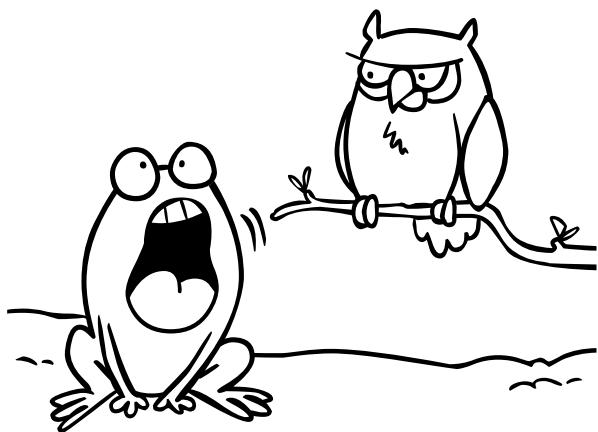

"Where is Turtle's house?"  
Frog asks Owl.

4



Owl giggles.

5

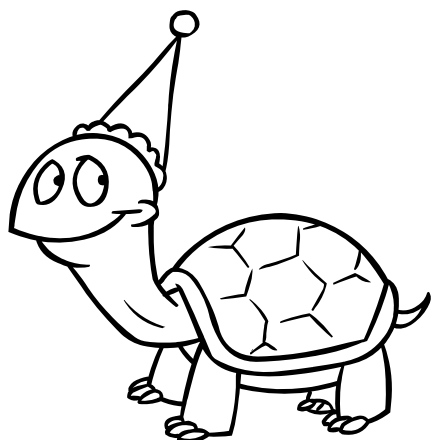

Here comes Turtle and  
his house!

6



Let the party begin!

7

Where does the story  
take place?

---

---

---

8

Who is your favorite  
character from the story?

---

---

---

9

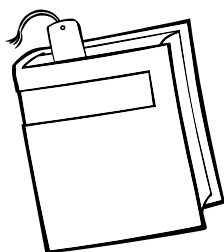

## Retelling a Story

**Directions:** Cut out the pages. Put them in order. Staple the pages together. Then read the story and answer the questions.

### Turtle's Party

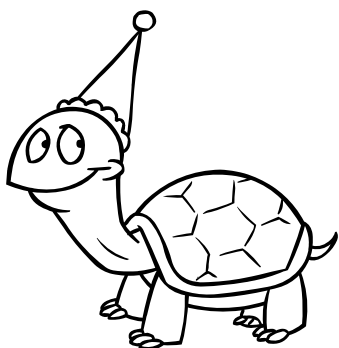

by Kathryn LaComb

Name \_\_\_\_\_



Turtle is having a party  
at his house.

1



"Where is Turtle's house?"  
Squirrel asks Beaver.

2

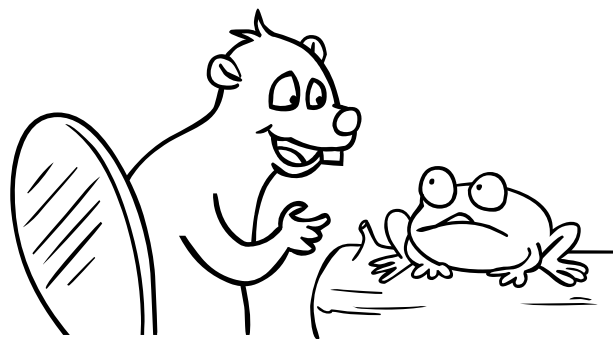

"Where is Turtle's house?"  
Beaver asks Frog.

3

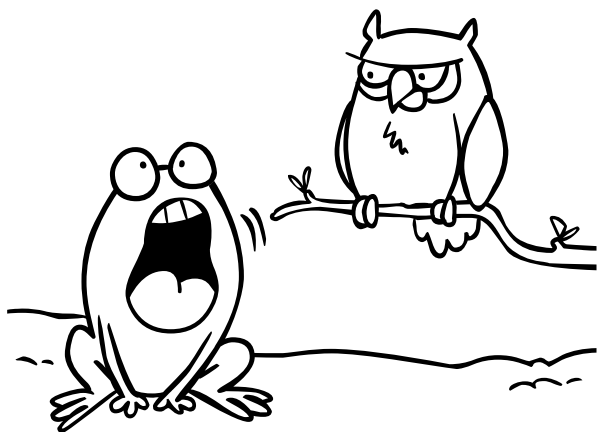

"Where is Turtle's house?"  
Frog asks Owl.

4



Owl giggles.

5

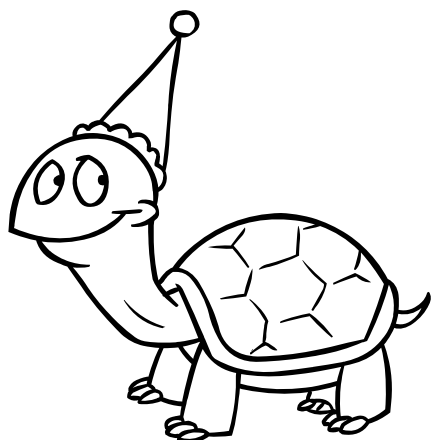

Here comes Turtle and  
his house!

6



Let the party begin!

7

Where does the story  
take place?

**Pictures  
will vary.**

\_\_\_\_\_

-----  
**in a forest**  
-----

8

Who is your favorite  
character from the story?

**Pictures  
will vary.**

\_\_\_\_\_

-----  
**Answers will vary.**  
-----

9

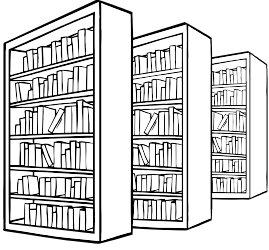

## Determining Meanings of Multiple Meaning Words

**Directions:** Draw a line to match the pictures that share the same name.

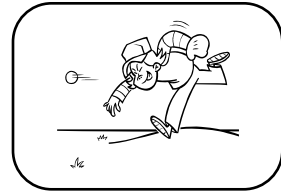
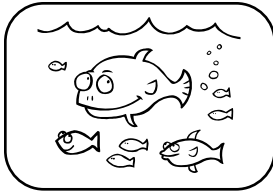
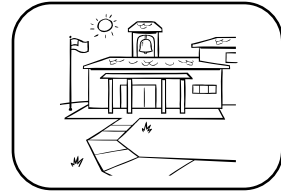
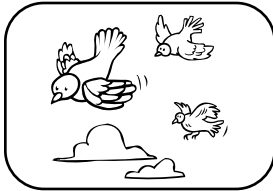
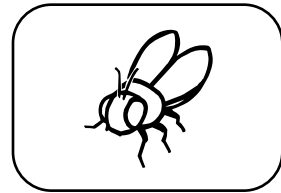
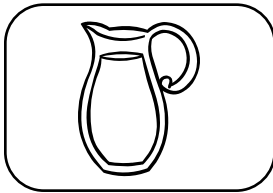

**Directions:** For each row, circle the picture that has the same beginning sound as the letter in the box.

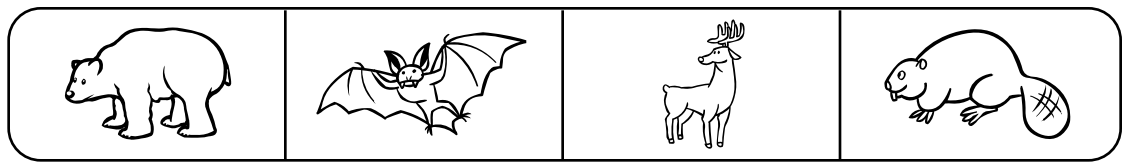
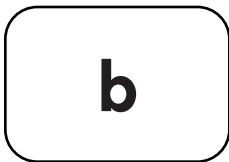

p

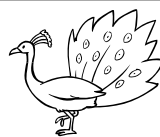

s



**Directions:** Cut out the puzzle. Say each sound as you build the puzzle. Blend the sounds together. Then read the word.

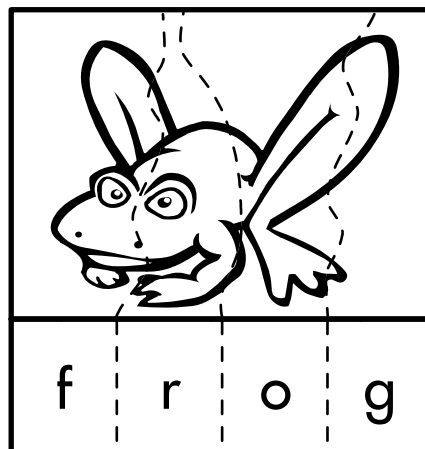
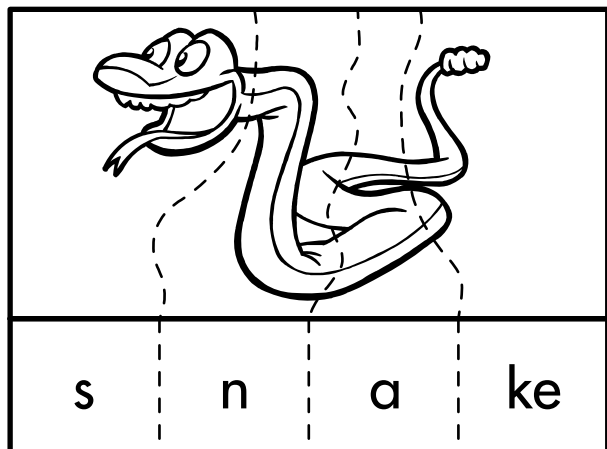



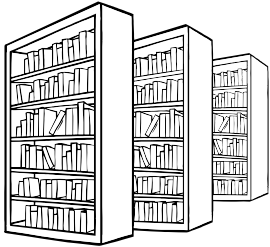





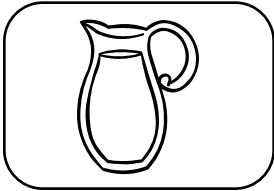
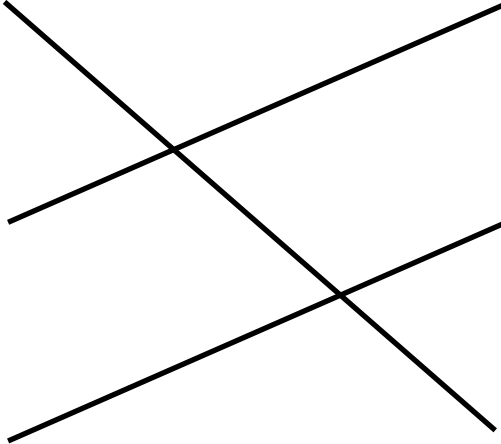
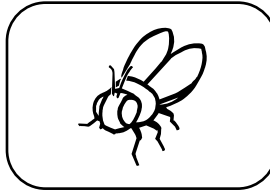
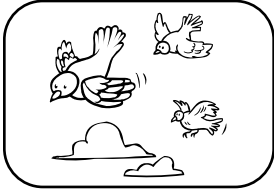
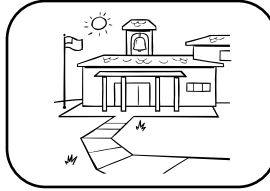
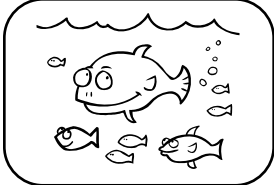
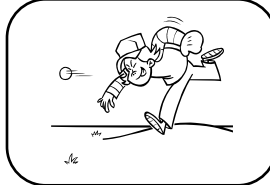

## Determining Meanings of Multiple Meaning Words

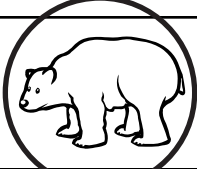
**Directions:** Draw a line to match the pictures that share the same name.

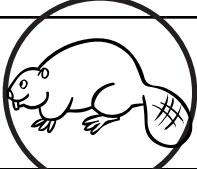

**Directions:** For each row, circle the picture that has the same beginning sound as the letter in the box.

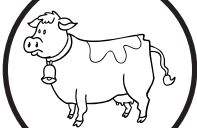
<b>b</b>				
<b>c</b>				

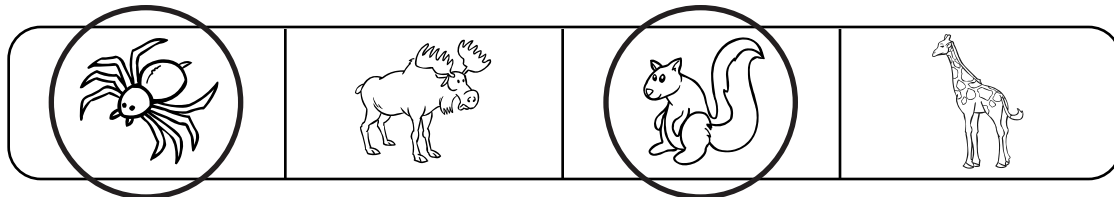
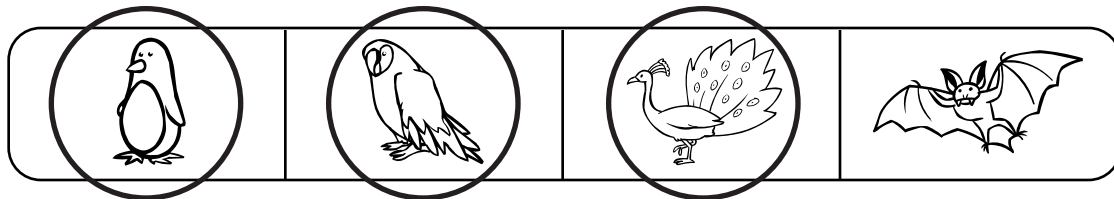

**Directions:** Cut out the puzzle. Say each sound as you build the puzzle. Blend the sounds together. Then read the word.

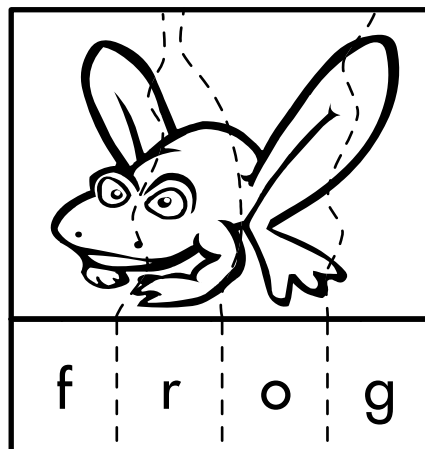
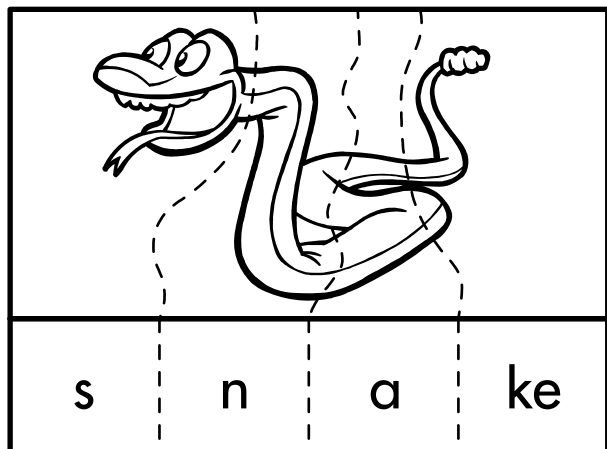

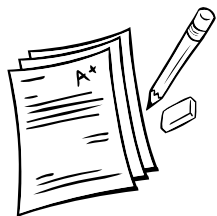

## Identifying Possessives and Pronouns

**Directions:** Read each sentence. Then circle the picture that shows who owns the object.

Here is Dad's cat.

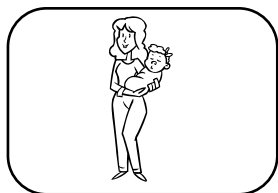

Mom

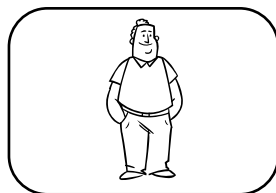

Dad

Ann's foot is on the mat.

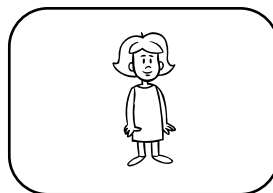

Ann

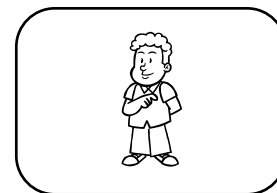

Sam

**Directions:** Read the sentences. Look for the words **for**, **on**, and **are**. Draw a ○ around the word **for**. Draw a □ around the word **on**. Underline the word **are**.

1. Pam has a  for Dan.  
gift

2. The cat sat on the .  
rat

3. They are on the .  
boat

4. Tom has a  for Mom.  
book

**Directions:** Read the story. Then draw pictures to answer the questions.

 is at .  
Rabbit home

 felt sad.  
Rabbit

She lost her .  
carrot

But  gave  an .  
Fox Rabbit apple

 gave  a .  
Snake Rabbit pear

 gave  a .  
Bear Rabbit banana

What good friends!

 smiled.  
Rabbit

Then she had , ,  
Fox Snake

and  over for dinner.  
Bear

Yum! Yum!

**Who?**

**What?**

**Where?**

**Directions:** For each row, circle the picture that begins with the same sound as the letter in the box.

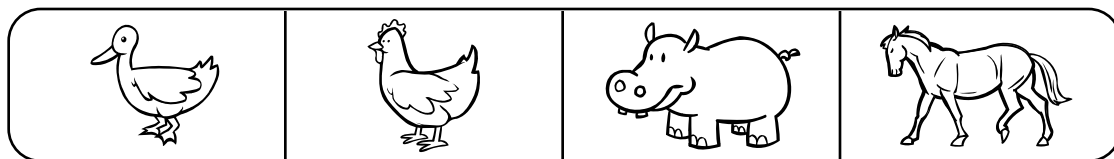
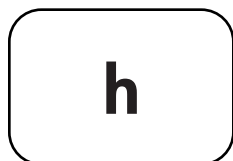
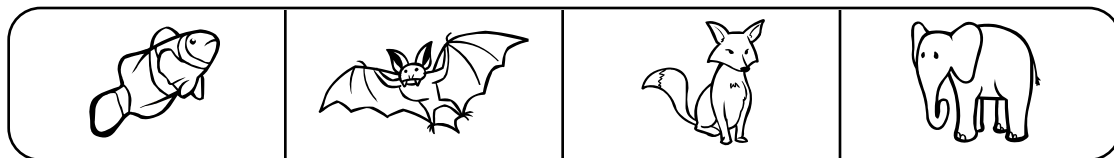

**Directions:** Cut out the puzzle. Say each sound as you build the puzzle. Blend the sounds together. Then read the word.

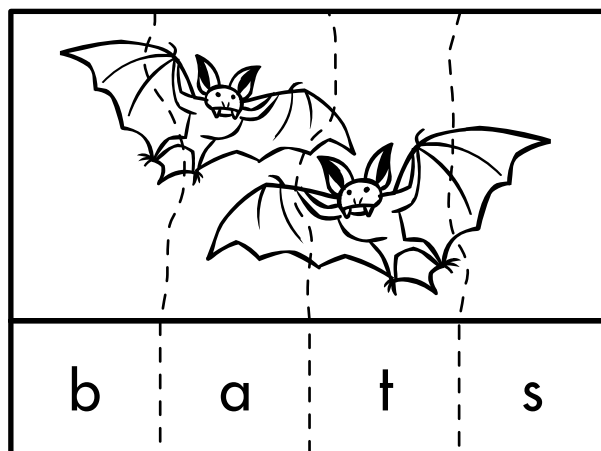
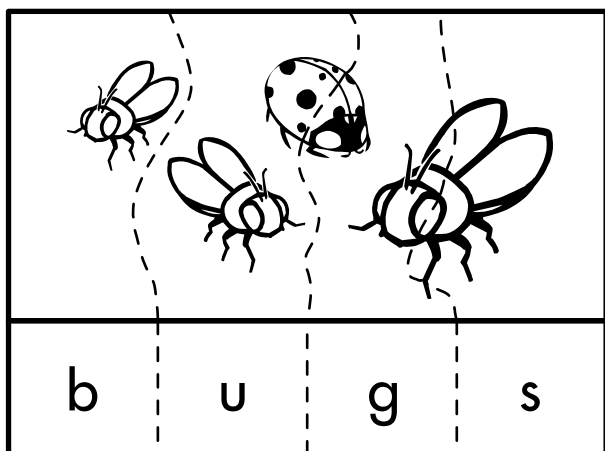



## Identifying Possessives and Pronouns

**Directions:** Read each sentence. Then circle the picture that shows who owns the object.

Here is Dad's cat.

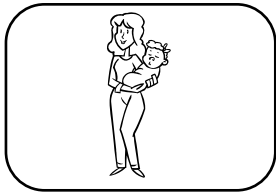

Mom

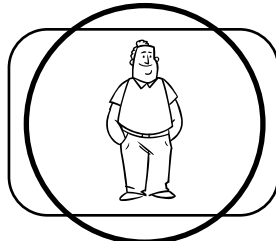

Dad

Ann's foot is on the mat.

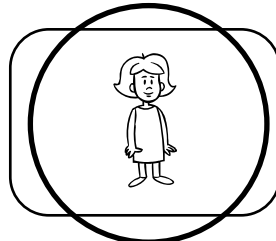

Ann

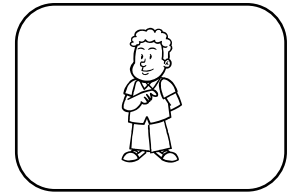

Sam

**Directions:** Read the sentences. Look for the words **for**, **on**, and **are**. Draw a ○ around the word **for**. Draw a □ around the word **on**. Underline the word **are**.

1. Pam has a  **for** Dan.  
gift

2. The cat sat **on** the .  
rat

3. They are **on** the .  
boat

4. Tom has a  **for** Mom.  
book

**Directions:** Read the story. Then draw pictures to answer the questions.

 is at .  
Rabbit home

 felt sad.  
Rabbit

She lost her .  
carrot

But  gave  an .  
Fox Rabbit apple

 gave  a .  
Snake Rabbit pear

 gave  a .  
Bear Rabbit banana

What good friends!

 smiled.  
Rabbit



Then she had  ,  ,  
Fox Snake

and  over for dinner.  
Bear

Yum! Yum!

**Who?**

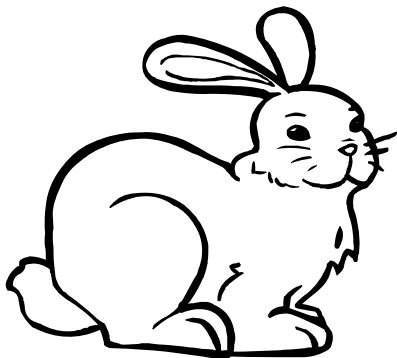

**What?**



**Where?**



**Directions:** For each row, circle the picture that begins with the same sound as the letter in the box.

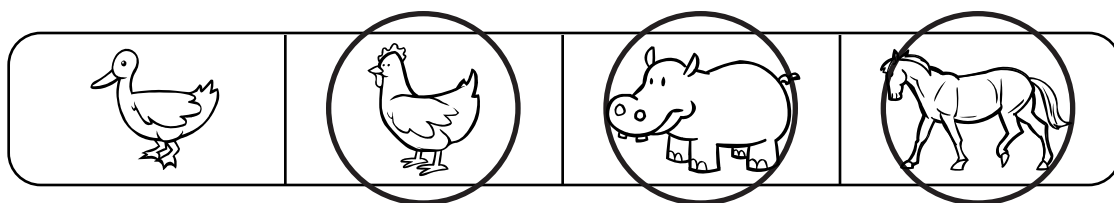
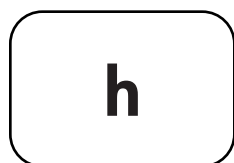
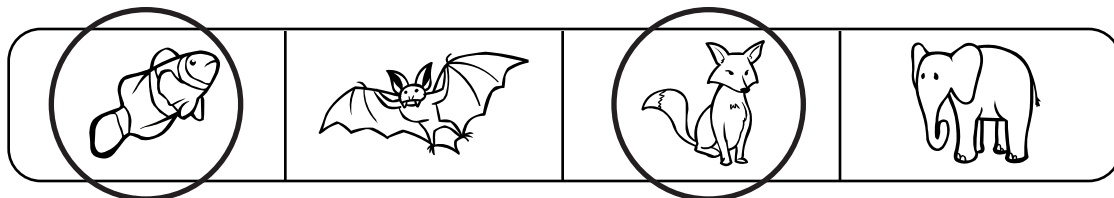

**Directions:** Cut out the puzzle. Say each sound as you build the puzzle. Blend the sounds together. Then read the word.

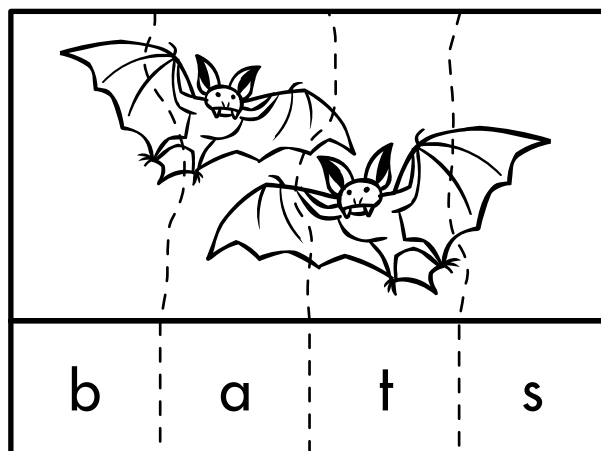
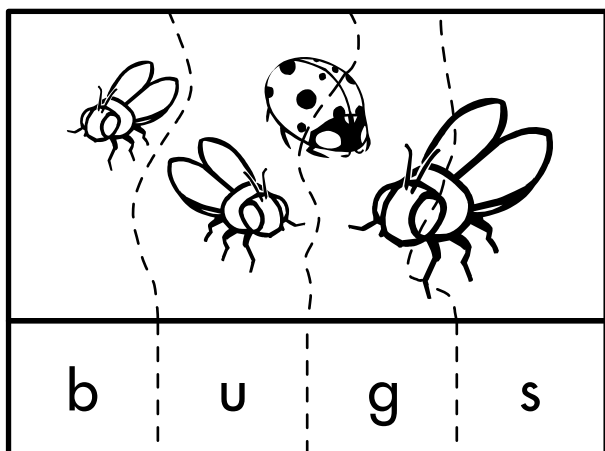

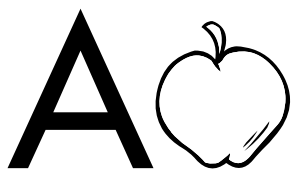

## Blend Phonemes into Whole Words

**Directions:** Draw a line from each letter to the picture that begins with the same sound.

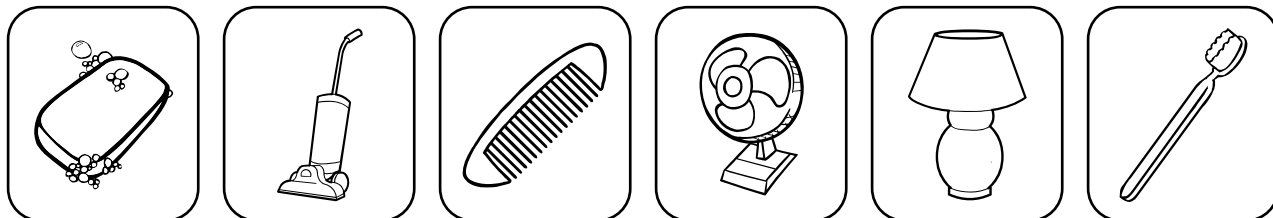
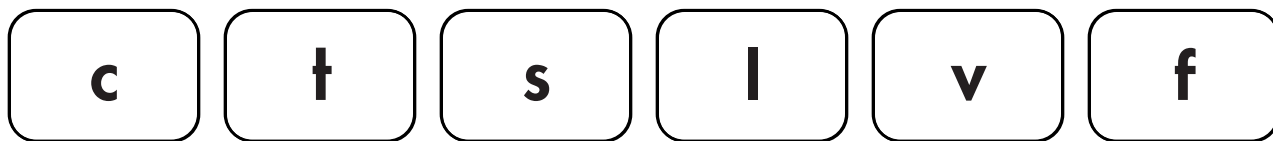

**Directions:** Cut out the puzzle. Say each sound as you build the puzzle. Blend the sounds together. Then read the word.

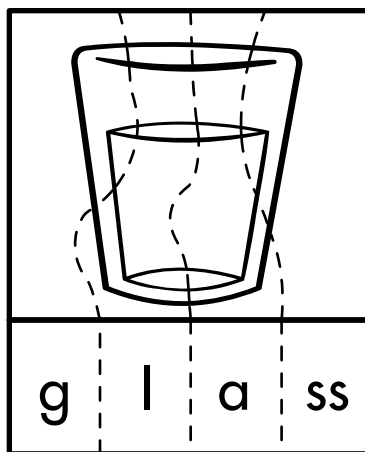
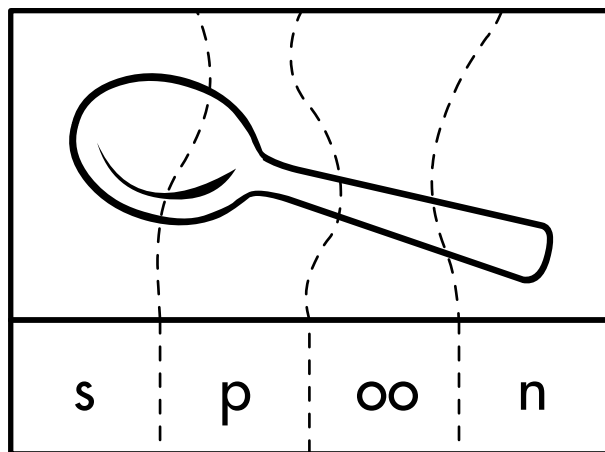

**Directions:** Cut out the letters below. Then paste them in the boxes to make a word that matches the picture.

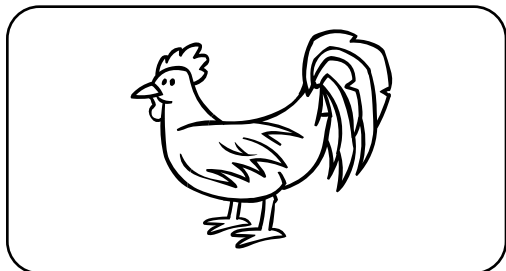

e

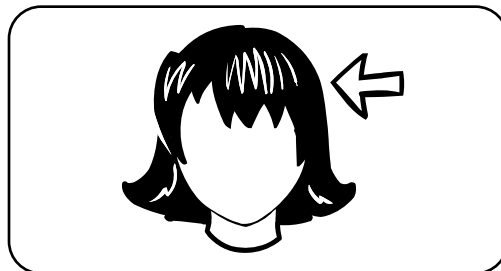

i

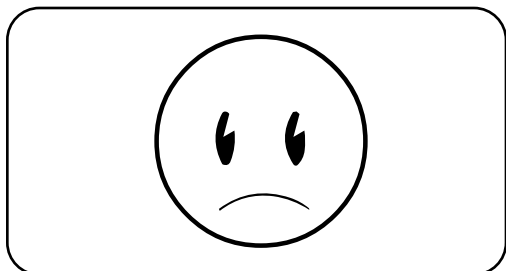

a

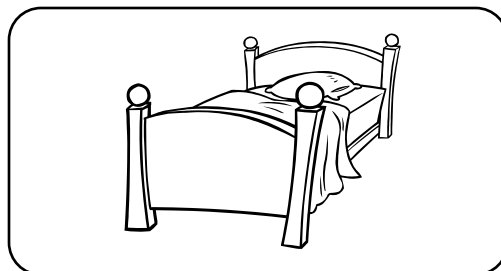

e

s	n	g	d
h	b	w	d

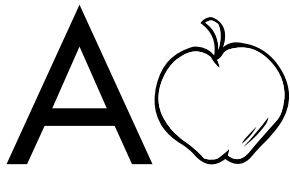

## Blend Phonemes into Whole Words

**Directions:** Draw a line from each letter to the picture that begins with the same sound.

c	t	s	l	v	f

*Note: Lines are drawn from 'c' to 'vacuum', 't' to 'toothbrush', 's' to 'soap', 'l' to 'lamp', 'v' to 'vacuum', and 'f' to 'fan'.*

**Directions:** Cut out the puzzle. Say each sound as you build the puzzle. Blend the sounds together. Then read the word.

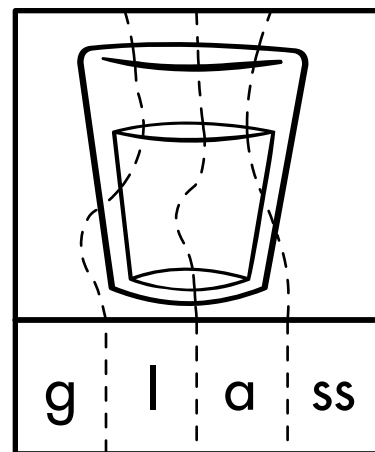
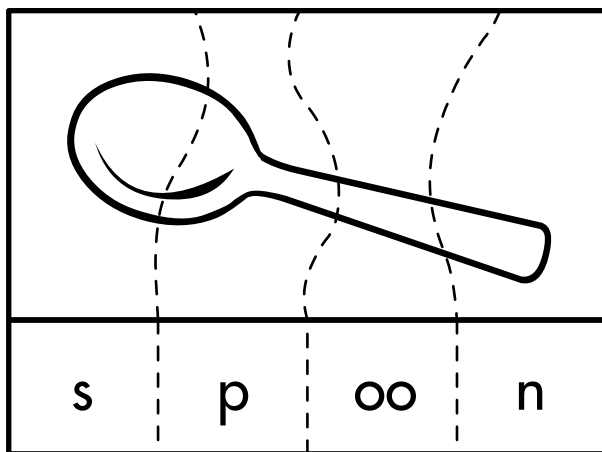

**Directions:** Cut out the letters below. Then paste them in the boxes to make a word that matches the picture.

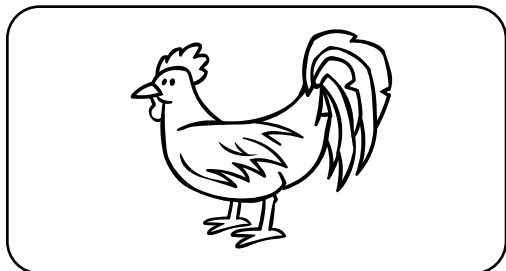

h

e

n

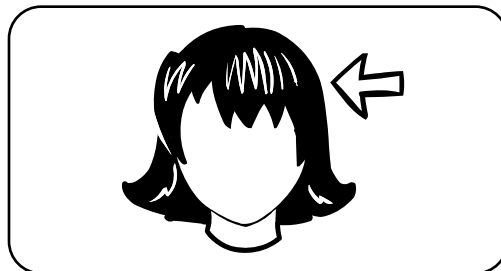

w

i

g

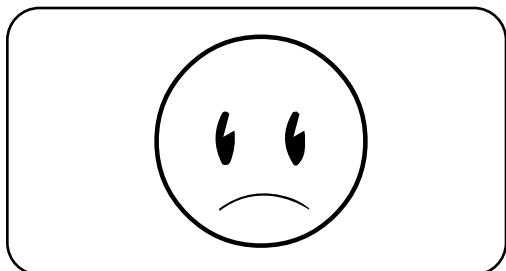

s

a

d

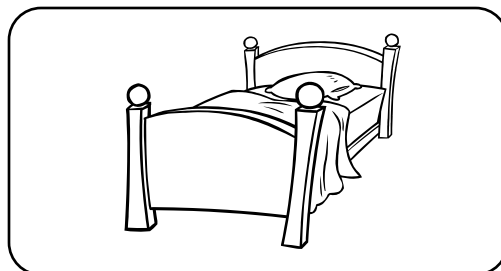

b

e

d

s	n	g	d
h	b	w	d

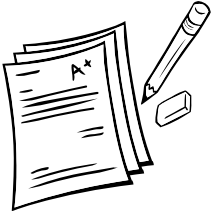

## Reading High Frequency Words

**Directions:** Look at the words below. Then read the story.

### Let's Play Ball

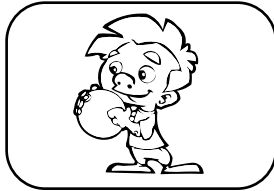

Dan

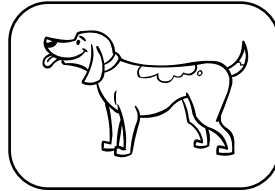

Sam

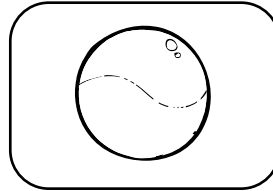

ball

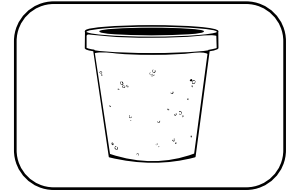

pot

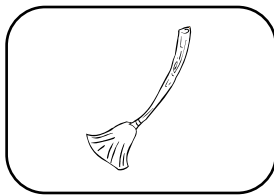

broom

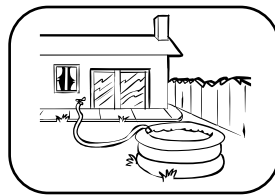

yard

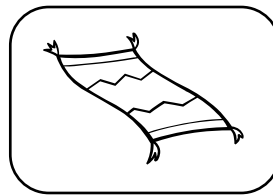

mat



sad

Dan is with his dog.  
 Dan and Sam are in the yard.  
 Dan and Sam run.  
 "Sam, go get the ball!" yells Dan.  
 Sam hits the pot.  
 "Oh no, Sam!" says Dan.  
 Dan gets the broom.  
 Sam sits on his mat.  
 Sam is sad.  
 "It's okay, Sam," says Dan.  
 "Let's play ball again!"

**Directions:** Draw pictures to answer the questions about the story.

Who?

Where?

What did Sam do?

What did Dan do?





## Reading High Frequency Words

**Directions:** Look at the words below. Then read the story.

### Let's Play Ball

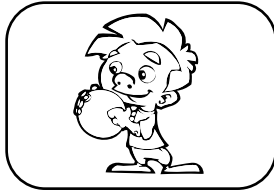

Dan

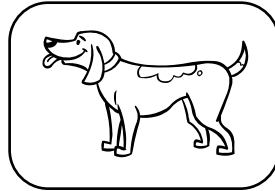

Sam

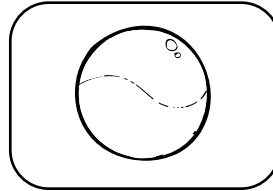

ball

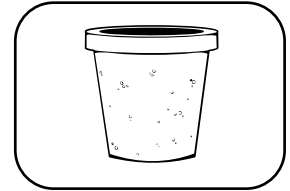

pot

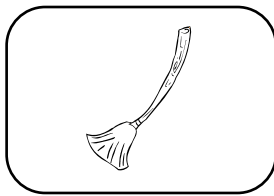

broom

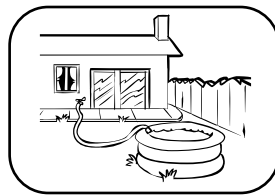

yard

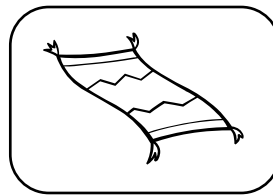

mat



sad

Dan is with his dog.  
 Dan and Sam are in the yard.  
 Dan and Sam run.  
 "Sam, go get the ball!" yells Dan.  
 Sam hits the pot.  
 "Oh no, Sam!" says Dan.  
 Dan gets the broom.  
 Sam sits on his mat.  
 Sam is sad.  
 "It's okay, Sam," says Dan.  
 "Let's play ball again!"

**Directions:** Draw pictures to answer the questions about the story.

Who?

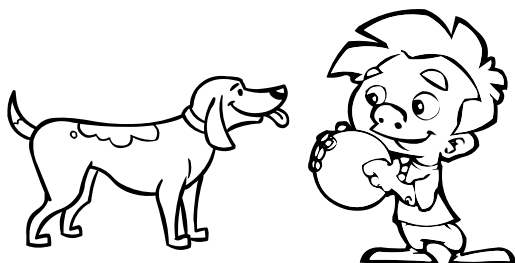

Where?

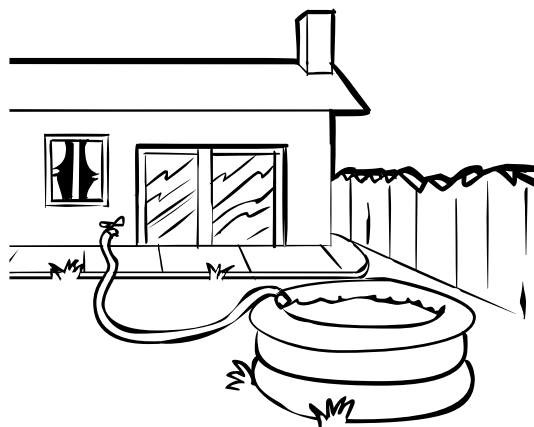

What did Sam do?



What did Dan do?



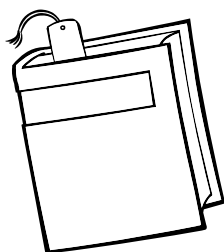

## Retelling a Story

**Directions:** Cut out the pages. Put them in order. Staple the pages together. Then read the story.

### Mike's Mystery House

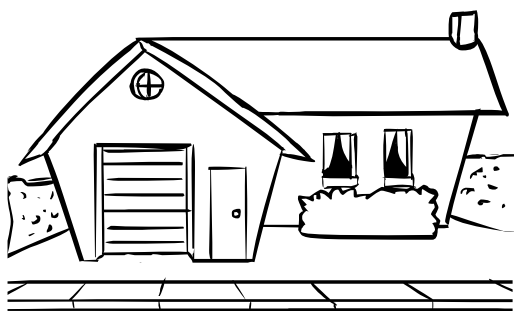

by Susan Motter Johnson

Name \_\_\_\_\_

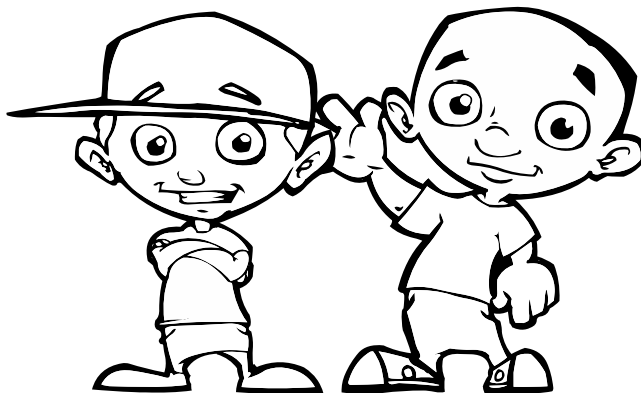

Mike and Caleb  
are friends.

1

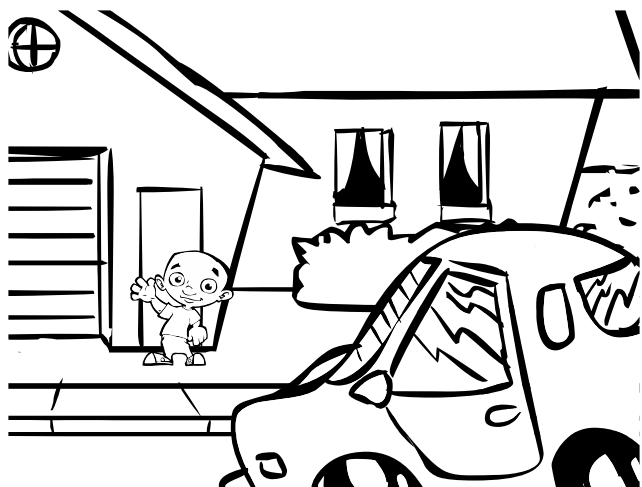

Caleb goes to  
Mike's house.

2

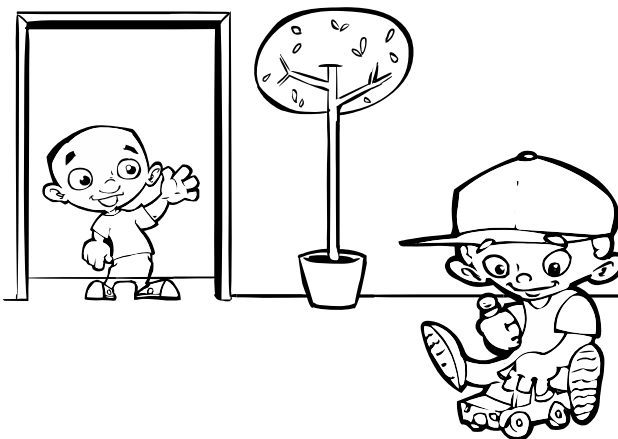

Mike has a tree in  
his bedroom.

3

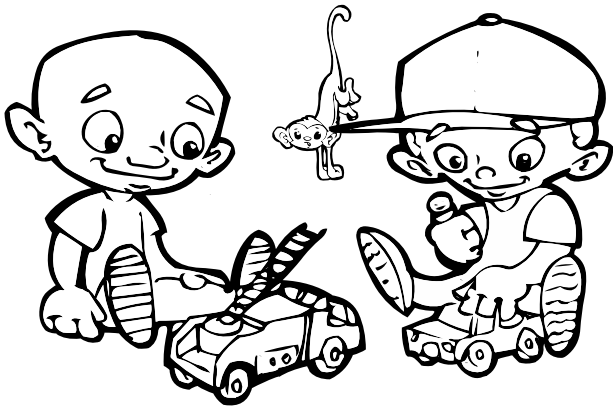

Mike has a monkey  
in his bedroom.

4

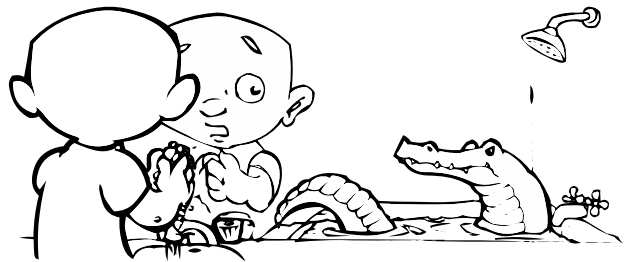

Mike has an alligator  
in the bathtub.

5



Mike has a parrot  
in the kitchen.

6

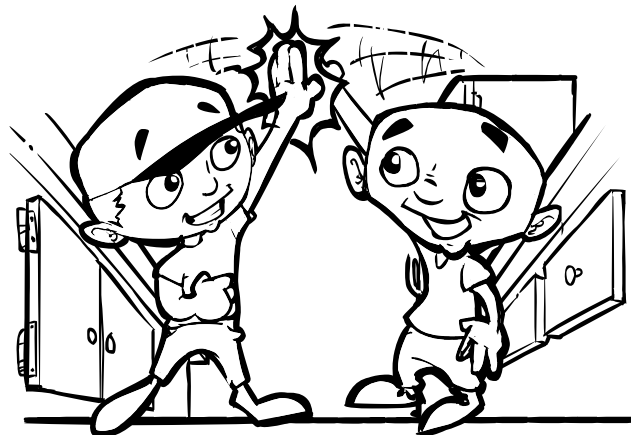

“Do you want to  
eat?” asks Mike. “No,  
thanks,” says Caleb. 7

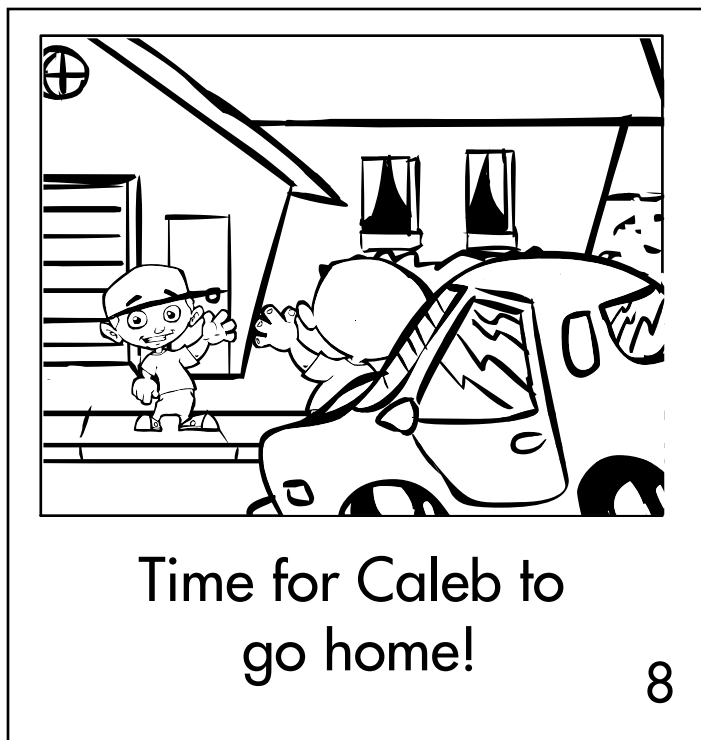

**Directions:** Cut out the pictures. Then paste them in the boxes to retell the story.

**Who?**

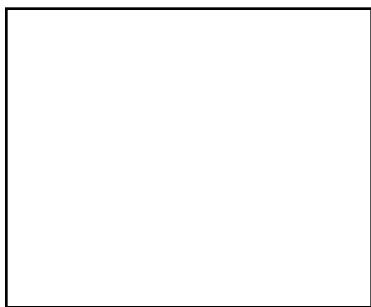

**Where?**

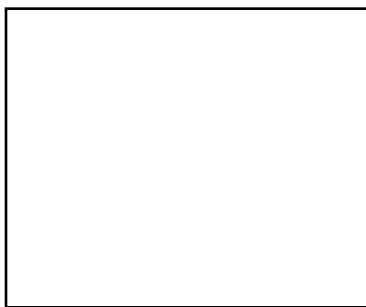

**What?**

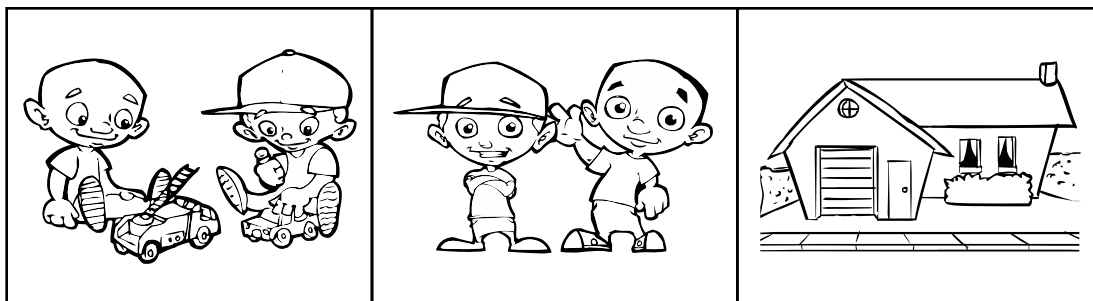
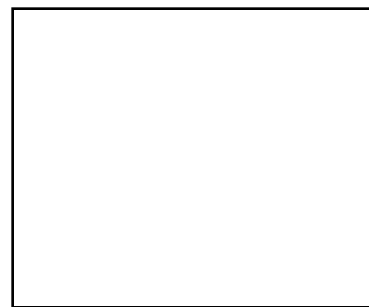

**Directions:** Cut out the pictures. Then paste them in boxes in the order they happen.

**First**



**Next**



**Last**



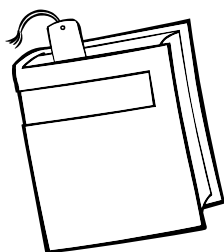

## Retelling a Story

**Directions:** Cut out the pages. Put them in order. Staple the pages together. Then read the story.

### Mike's Mystery House

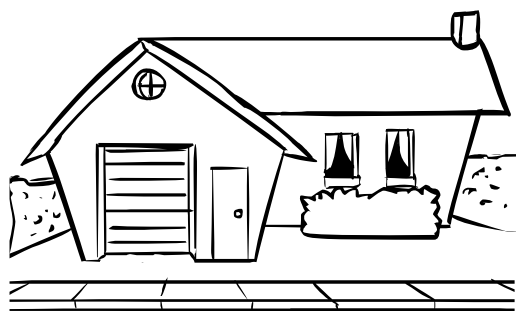

by Susan Motter Johnson

Name \_\_\_\_\_

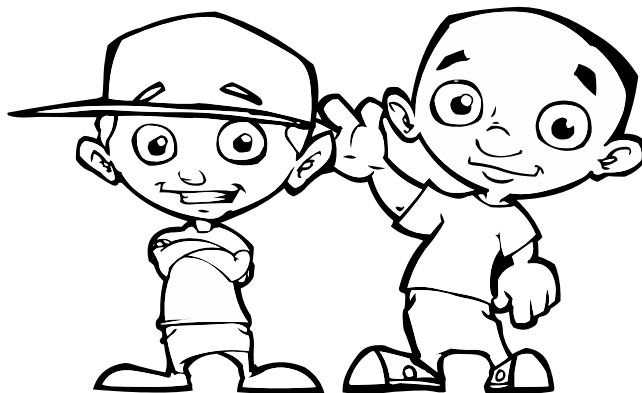

Mike and Caleb  
are friends.

1

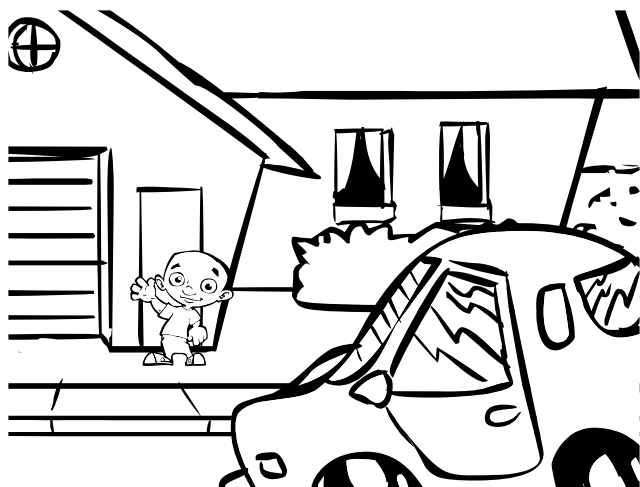

Caleb goes to  
Mike's house.

2

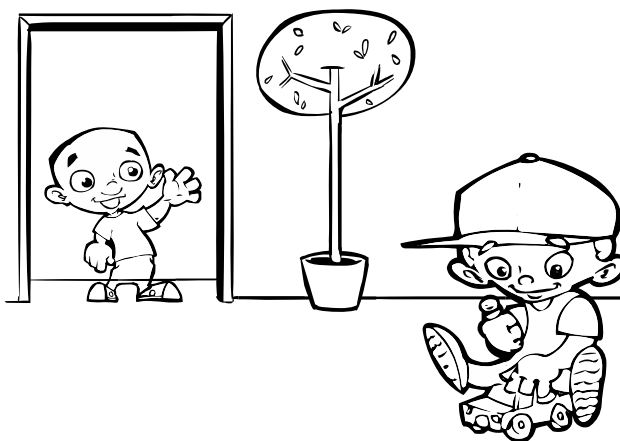

Mike has a tree in  
his bedroom.

3

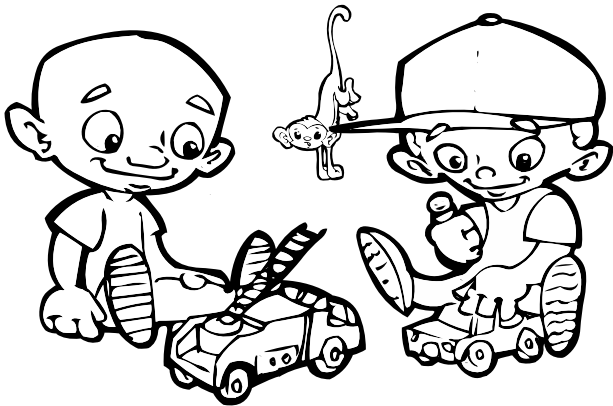

Mike has a monkey  
in his bedroom.

4

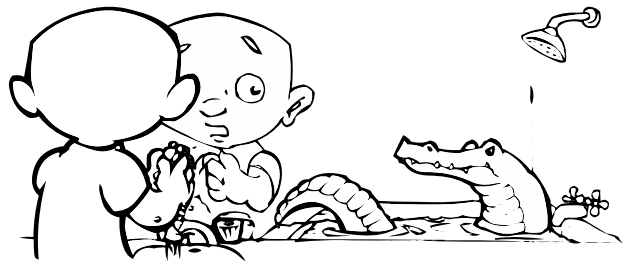

Mike has an alligator  
in the bathtub.

5



Mike has a parrot  
in the kitchen.

6

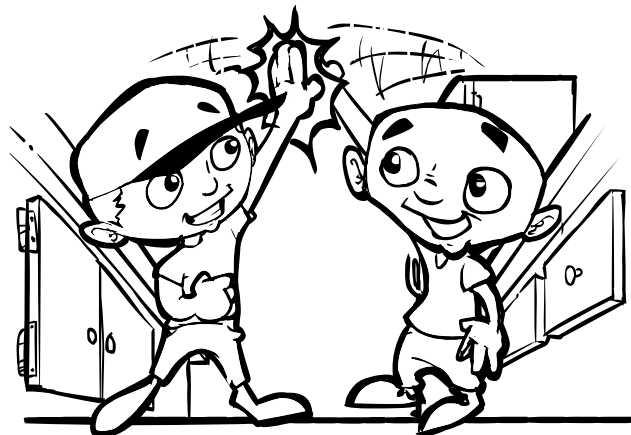

“Do you want to  
eat?” asks Mike. “No,  
thanks,” says Caleb. 7



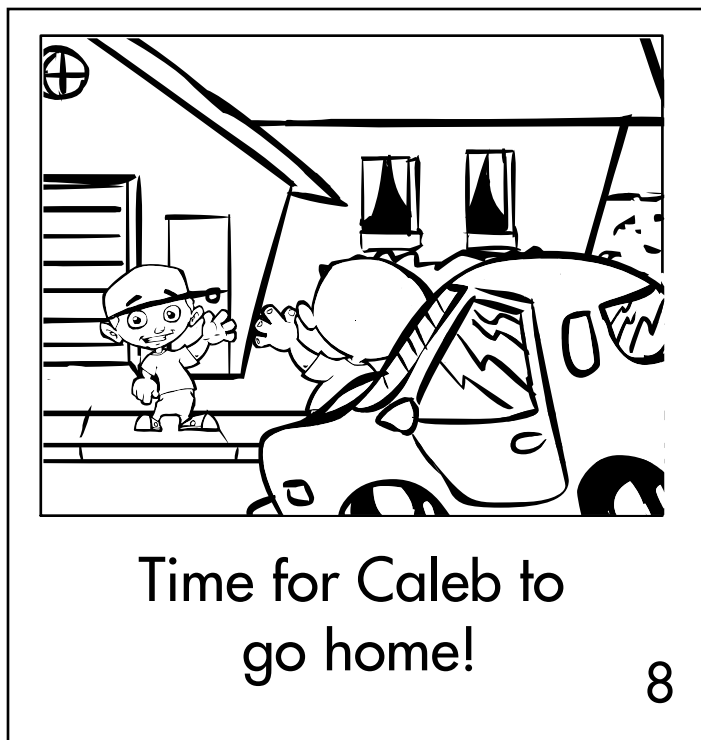

**Directions:** Cut out the pictures. Then paste them in the boxes to retell the story.

**Who?**

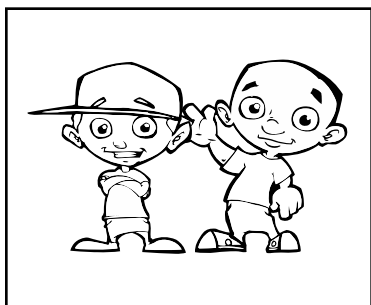

**Where?**

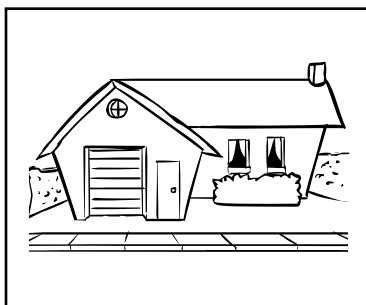

**What?**

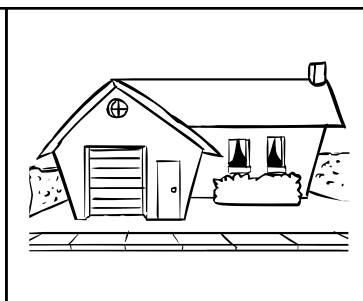
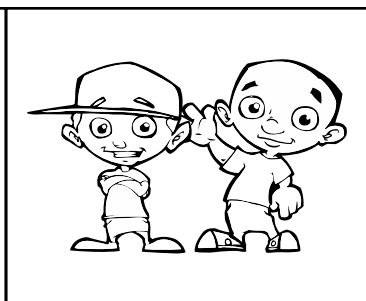
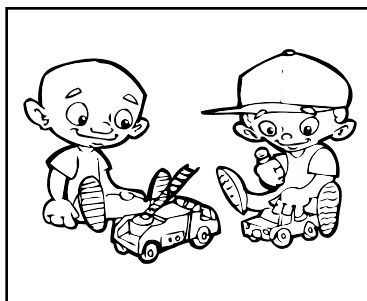
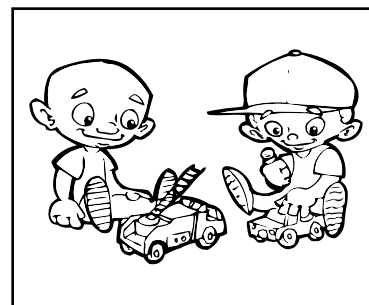

**Directions:** Cut out the pictures. Then paste them in boxes in the order they happen.

**First**

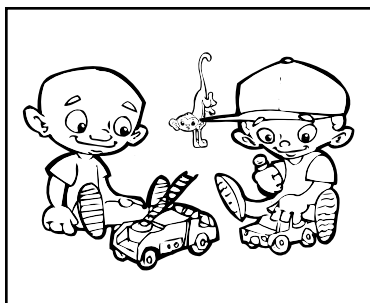

**Next**



**Last**

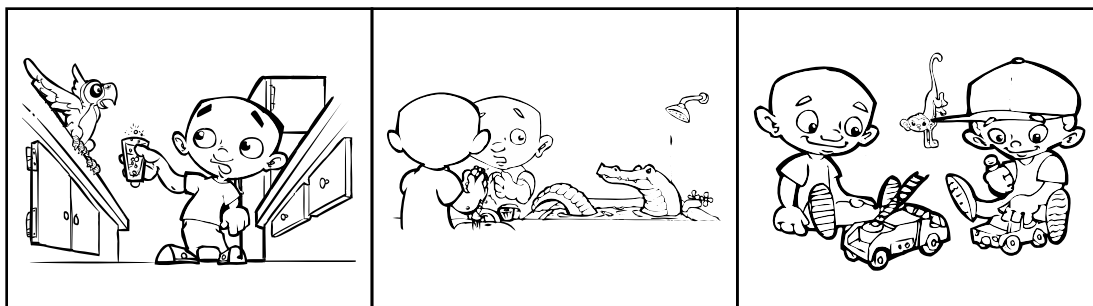
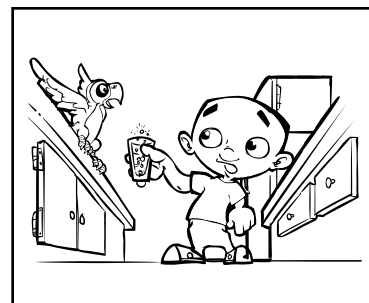

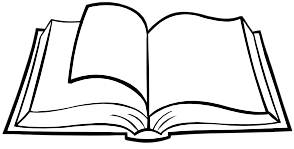

## Blending CVC Words in Context

**Directions:** Cut out the pages. Put them in order. Staple the pages together. Then read the story.

### My Farm Book

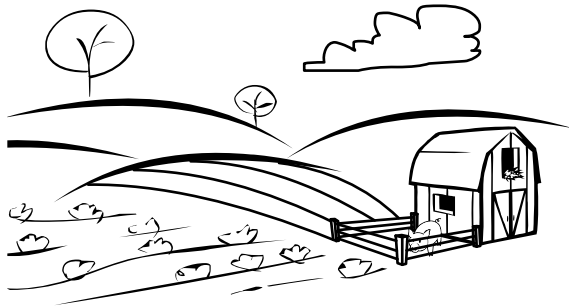

by Erin Lassiter

Name \_\_\_\_\_

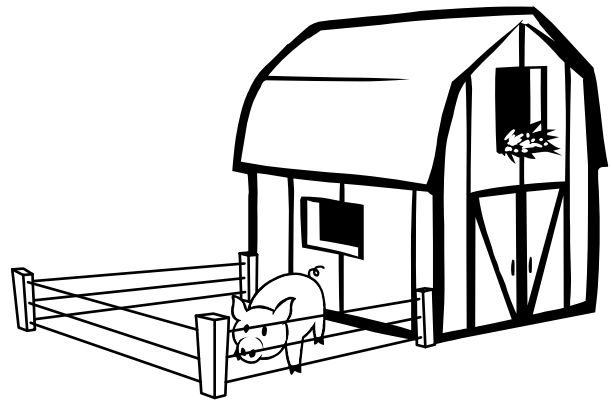

The pig is in the pen.

1

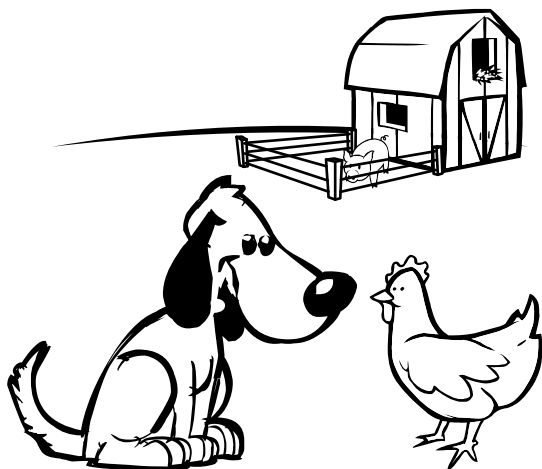

The hen is with the dog.

2

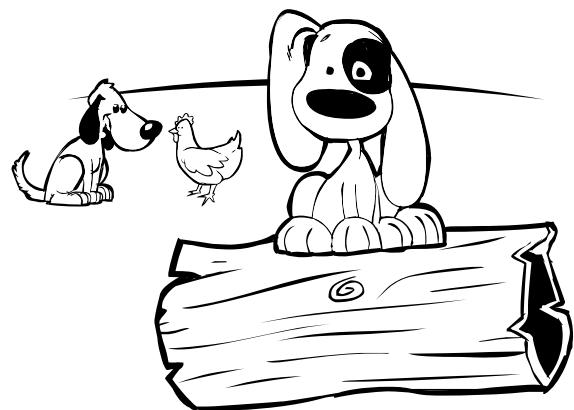

The pup is on the log.

3

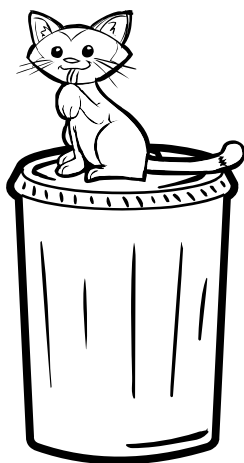

The cat is on a bin.

4



The bug is on the cow.

5

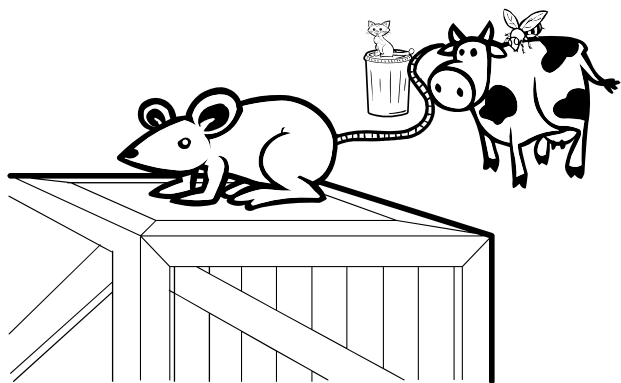

The rat is on a box.

6

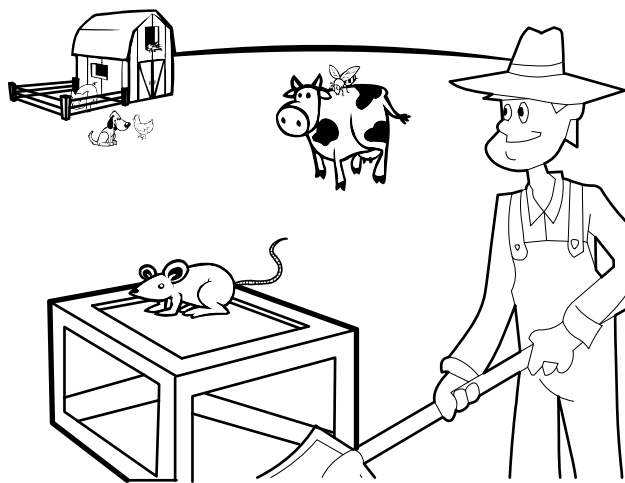

The hat is on the man.

7

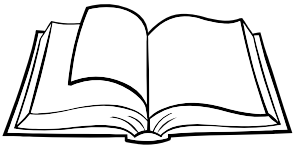

## Blending CVC Words in Context

**Directions:** Cut out the pages. Put them in order. Staple the pages together. Then read the story.

### My Farm Book

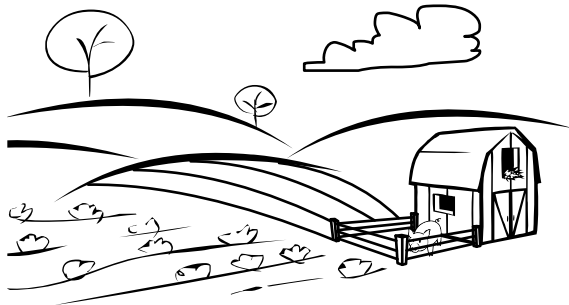

by Erin Lassiter

Name \_\_\_\_\_

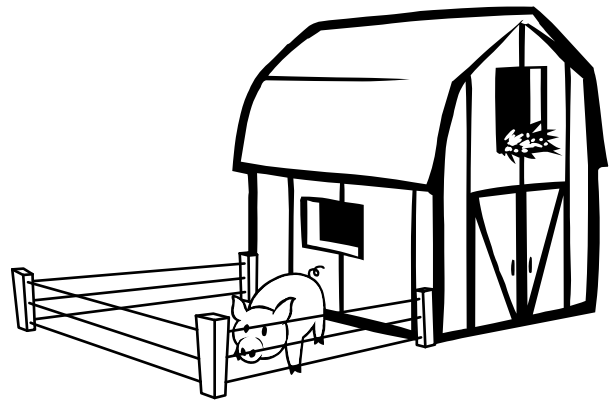

The pig is in the pen.

1

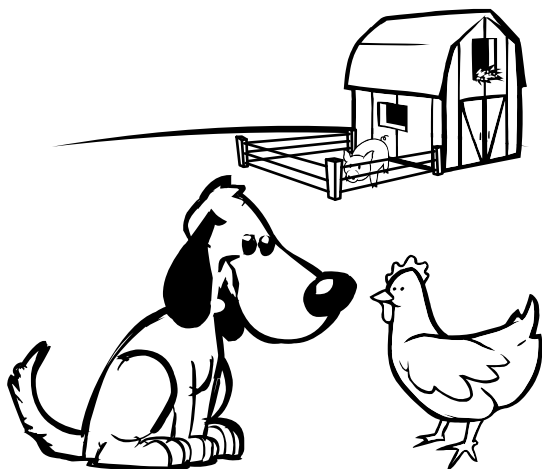

The hen is with the dog.

2

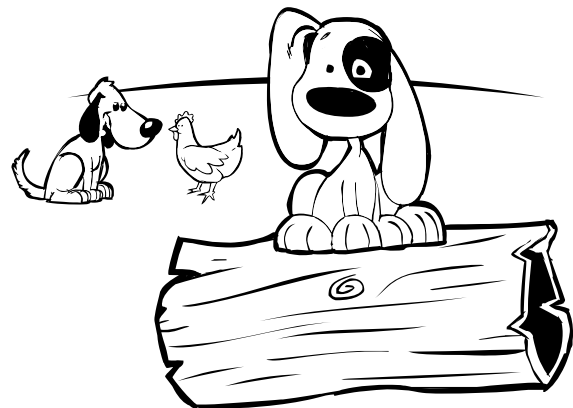

The pup is on the log.

3

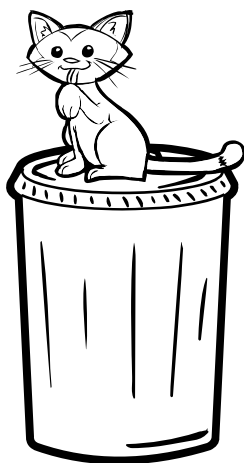

The cat is on a bin.

4



The bug is on the cow.

5

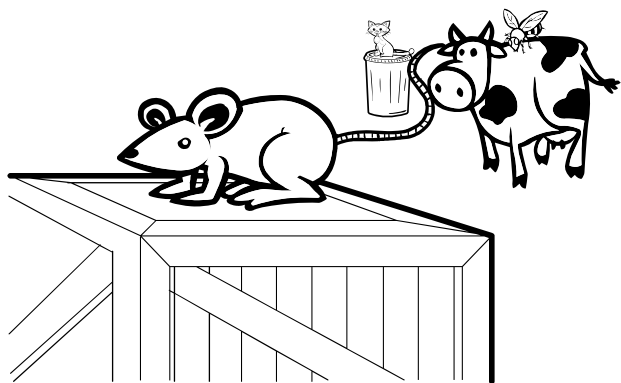

The rat is on a box.

6

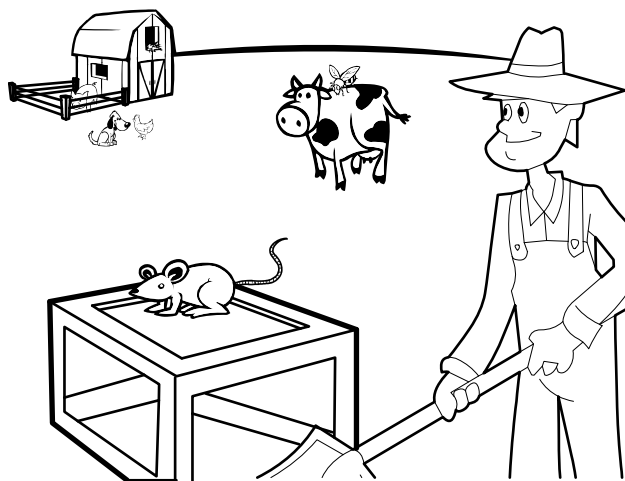

The hat is on the man.

7

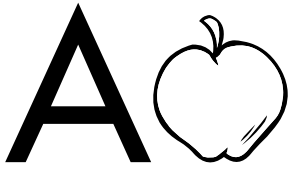

## Retelling a Story and Blending and Segmenting Phonemes

**Directions:** Read the story.

The man is with his dog.

The dog sees a cat.

The cat runs.

The dog runs.

The man runs.

**Directions:** Draw the events of the story in order.

**First**

A large, empty square with rounded corners and a thin black border, intended for drawing the first event of the story.

**Next**

A large, empty square with rounded corners and a thin black border, intended for drawing the next event of the story.

**Last**

A large, empty square with rounded corners and a thin black border, intended for drawing the last event of the story.

**Directions:** Cut out the puzzle. Say each sound as you build the puzzle. Blend the sounds together. Then read the word.





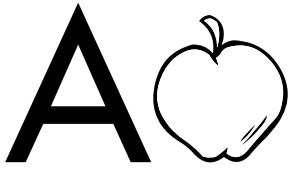

## Retelling a Story and Blending and Segmenting Phonemes

**Directions:** Read the story.

The man is with his dog.

The dog sees a cat.

The cat runs.

The dog runs.

The man runs.

**Directions:** Draw the events of the story in order.

**First**

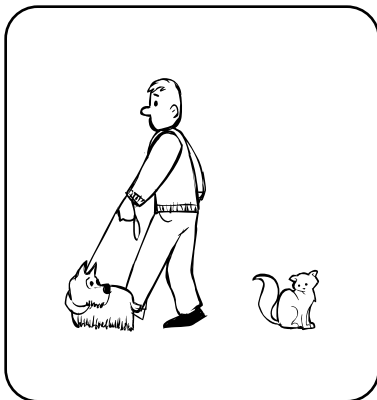

**Next**

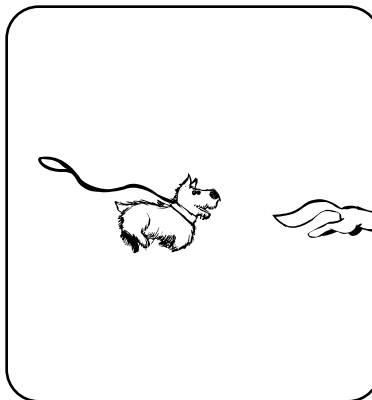

**Last**

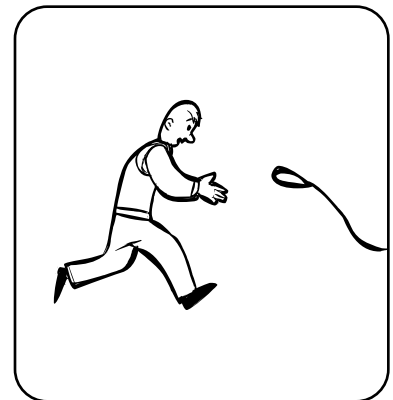

**Directions:** Cut out the puzzle. Say each sound as you build the puzzle. Blend the sounds together. Then read the word.





## aeiou Distinguishing Consonants and Vowels

**Directions:** Look at the letters. Then circle all the vowels.

B	e	f	o	z
U	I	K	m	W
h	c	Q	r	A

**Directions:** Look at the words. Then circle the vowels in the words.

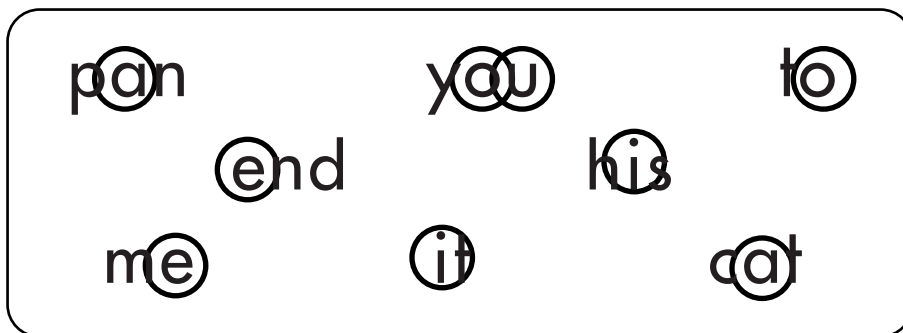

**Directions:** Cut out the puzzle. Say each sound as you build the puzzle. Blend the sounds together. Then read the word.

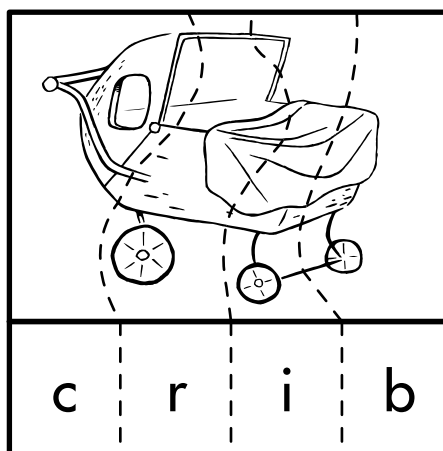
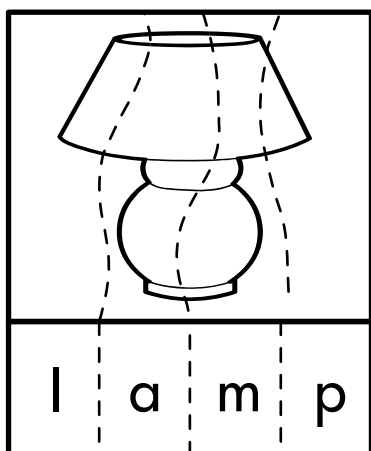

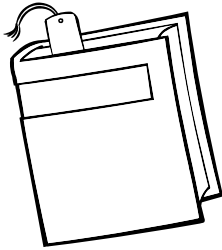

## Retelling a Story

**Directions:** Cut out the pages. Put them in order. Staple the pages together. Then read the story and answer the questions.

### Block Party

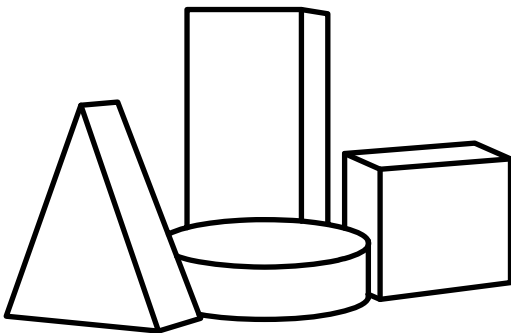

by Barbara Davis-Pyles

Name \_\_\_\_\_



Ida had blue blocks.  
They were triangles. 1

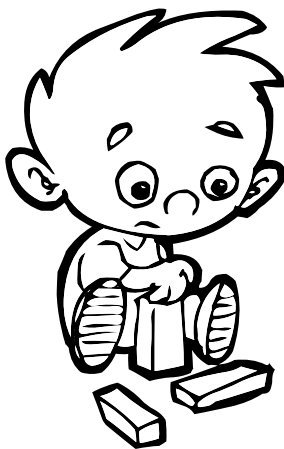

Jack had red blocks.  
They were rectangles. 2



Zola had orange blocks.  
They were circles. 3

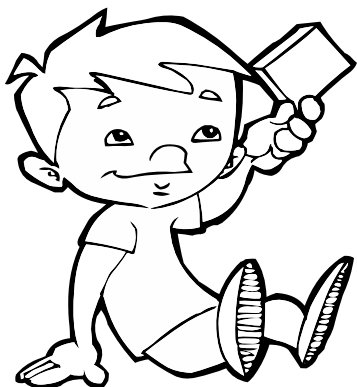

Lucas had green blocks.  
They were squares.

4

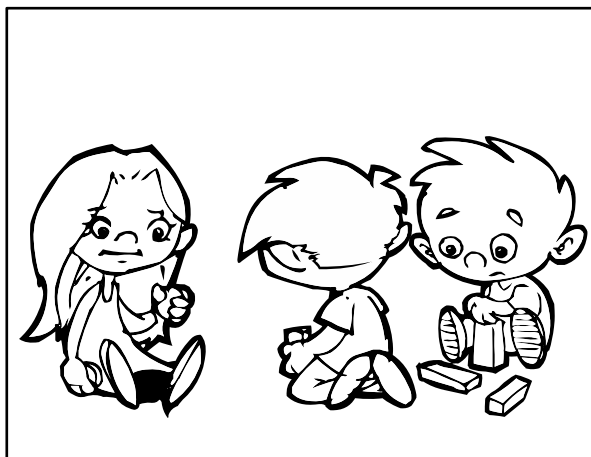

The friends were bored.  
They were bored of  
their blocks.

5



Ida smiled and said,  
“I know! Let’s mix  
and match!”

6

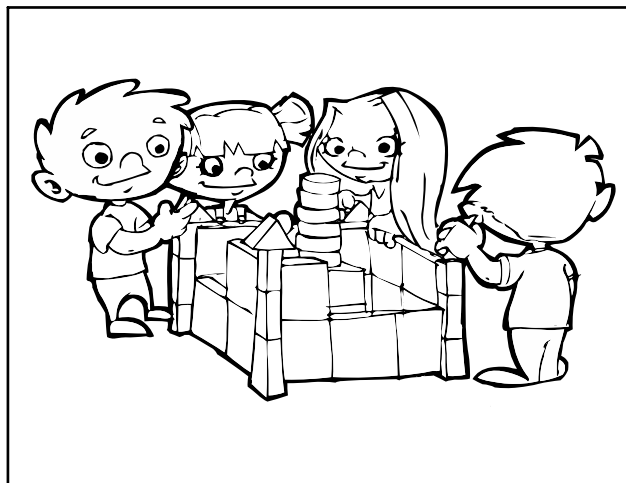

They stacked and  
stacked.

7

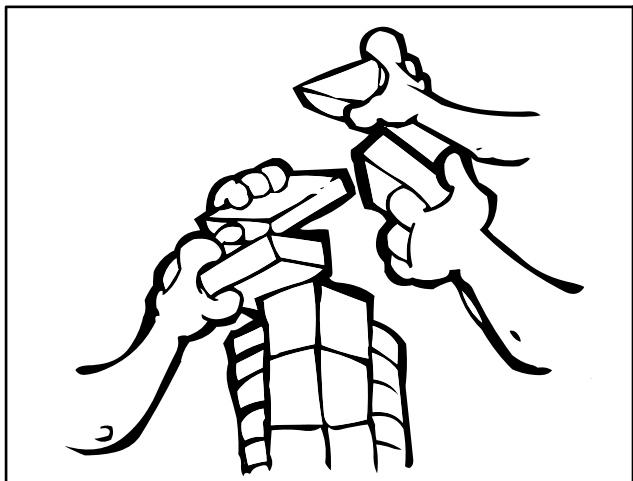

They stacked every last block.

8

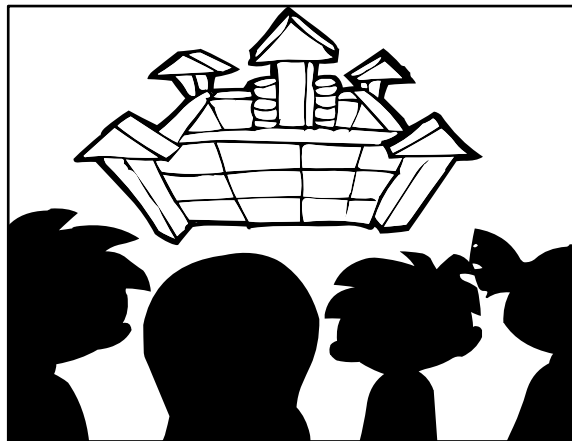

The friends built a castle. They built a colorful castle!

9

**Directions:** Draw a picture for each part of the story.

## Main Characters

## Problem

## Solution



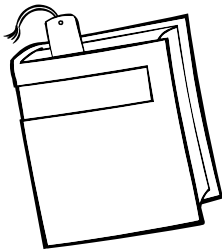

## Retelling a Story

**Directions:** Cut out the pages. Put them in order. Staple the pages together. Then read the story and answer the questions.

### Block Party

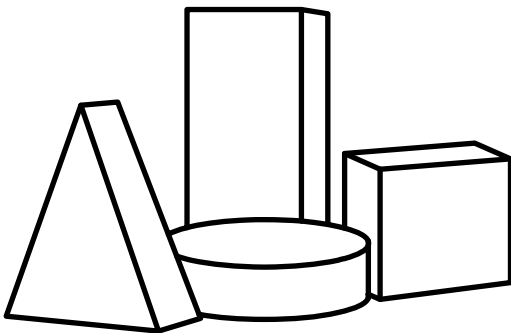

by Barbara Davis-Pyles

Name \_\_\_\_\_



Ida had blue blocks.  
They were triangles. 1

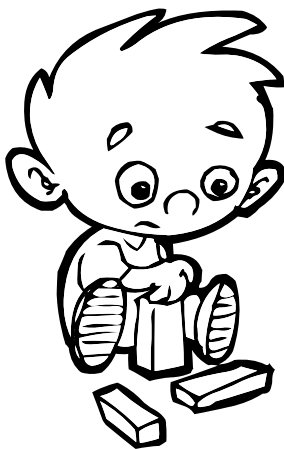

Jack had red blocks.  
They were rectangles. 2



Zola had orange blocks.  
They were circles. 3



Lucas had green blocks.  
They were squares.

4

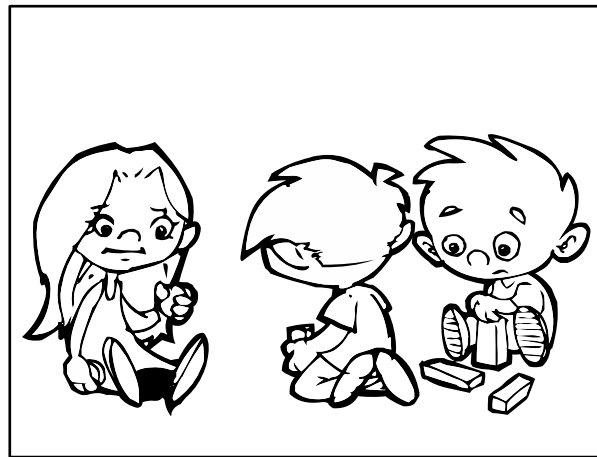

The friends were bored.  
They were bored of  
their blocks.

5

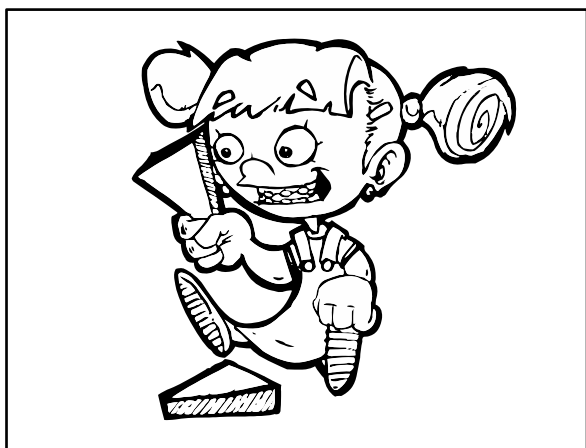

Ida smiled and said,  
“I know! Let’s mix  
and match!”

6

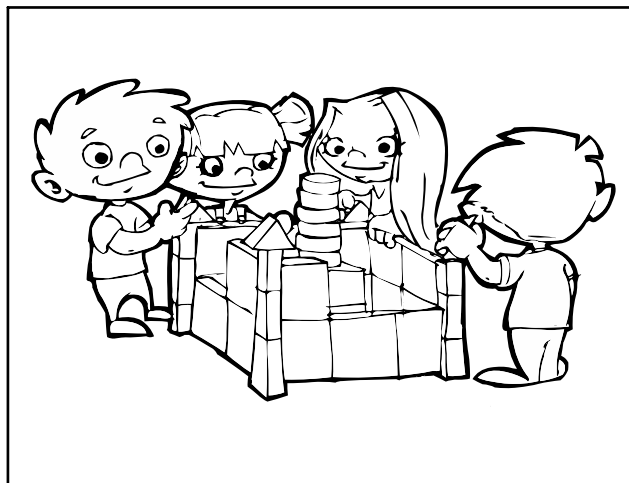

They stacked and  
stacked.

7

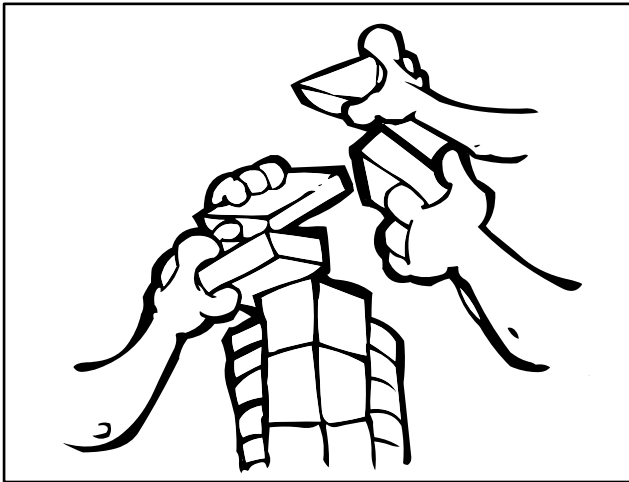

They stacked every last block.

8

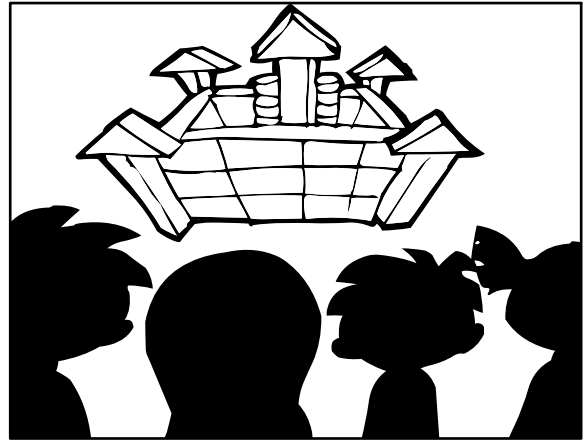

The friends built a castle. They built a colorful castle!

9

**Directions:** Draw a picture for each part of the story.

## Main Characters

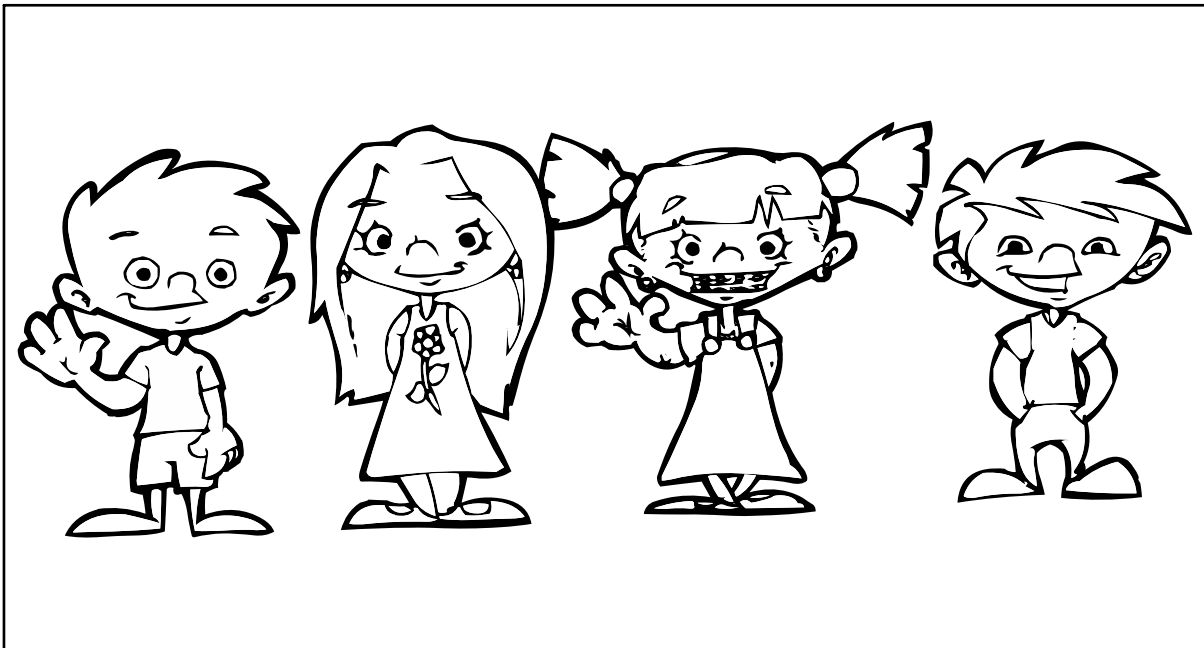

## Problem

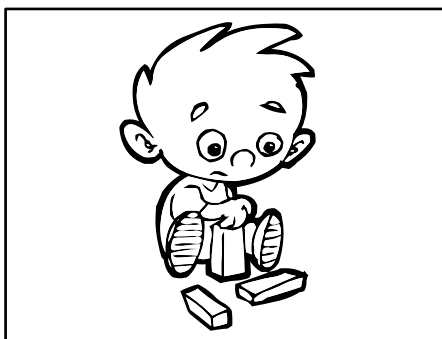
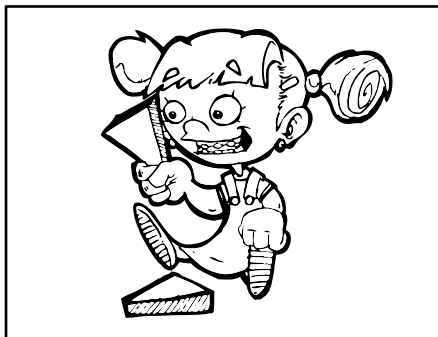

## Solution

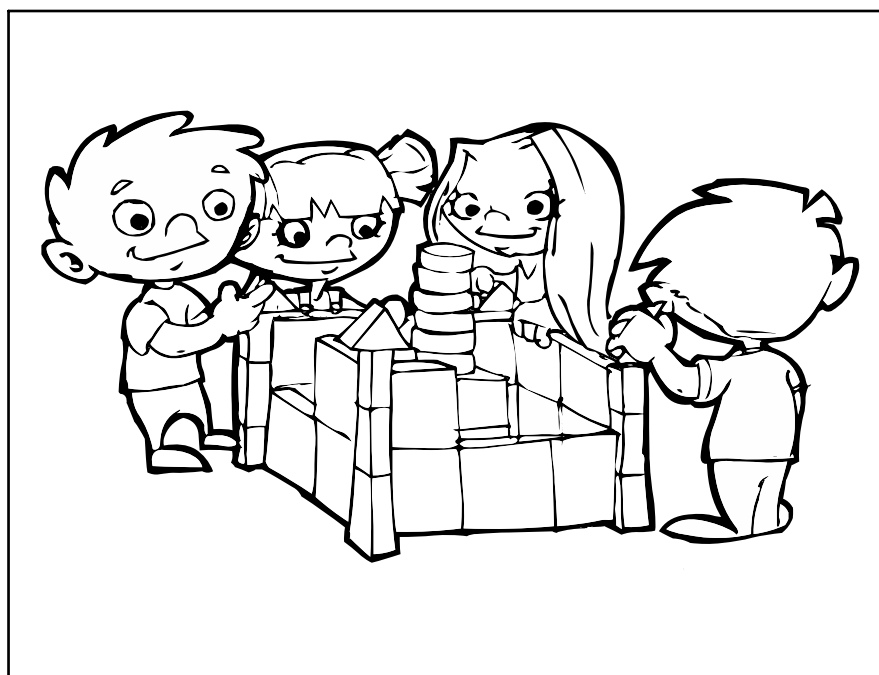



## Retelling a Story

**Directions:** Cut out the pages and put them in order. Staple the pages together. Then read the story and answer the questions.

### At the Zoo



by Nicole Mead

Name \_\_\_\_\_



We went to the zoo.

1

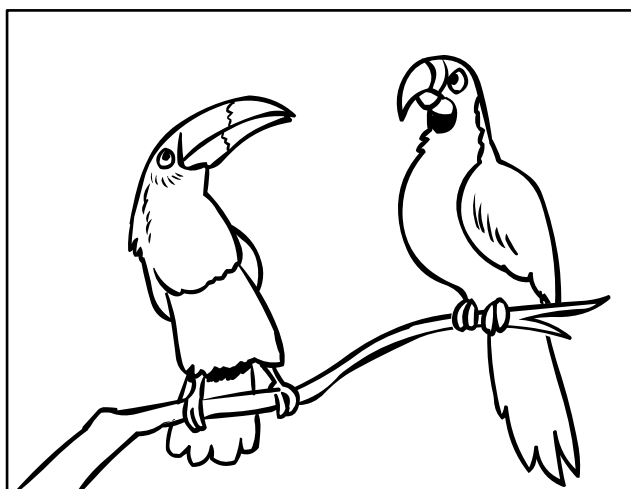

I saw lots of birds  
at the zoo.

2

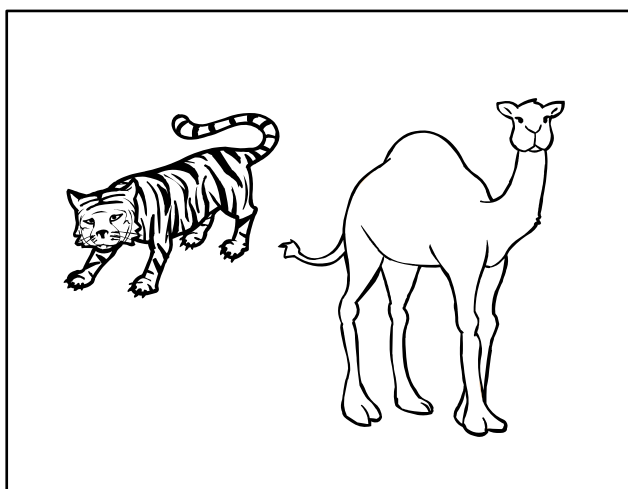

They saw camels  
and tigers at the zoo.

3

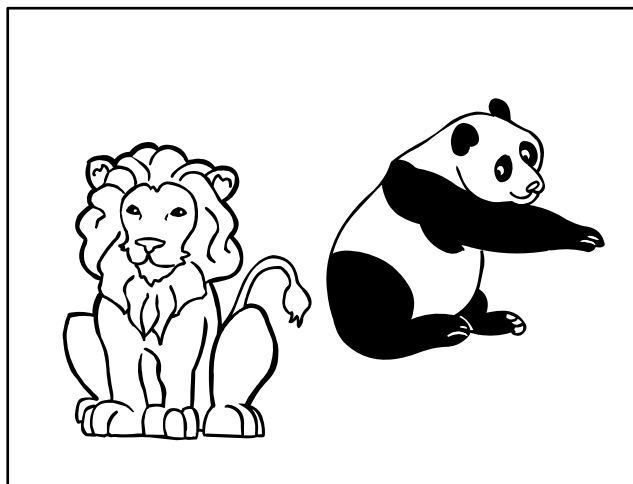

I saw lions and panda bears at the zoo.

4

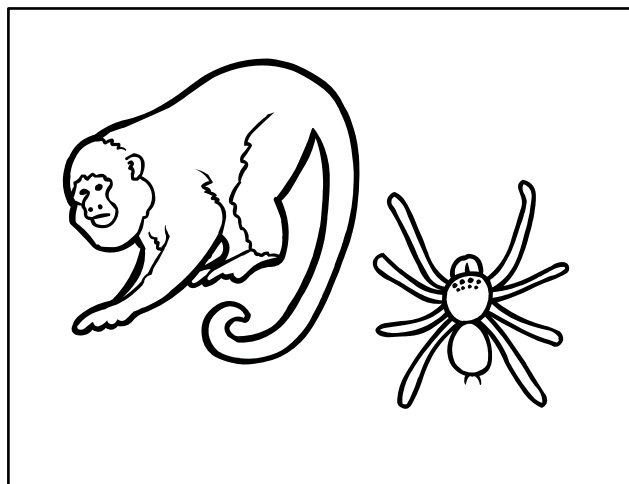

They saw monkeys and big spiders at the zoo!

5

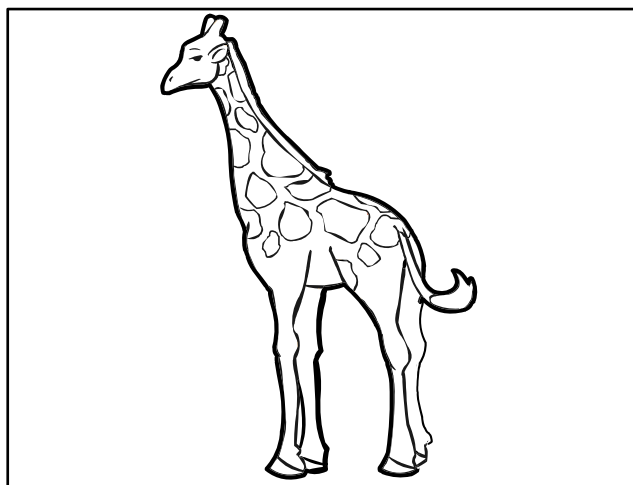

I saw the giraffe at the zoo.

6



They did not see the snakes at the zoo.

7

**Directions:** Draw a picture of who the story is about.

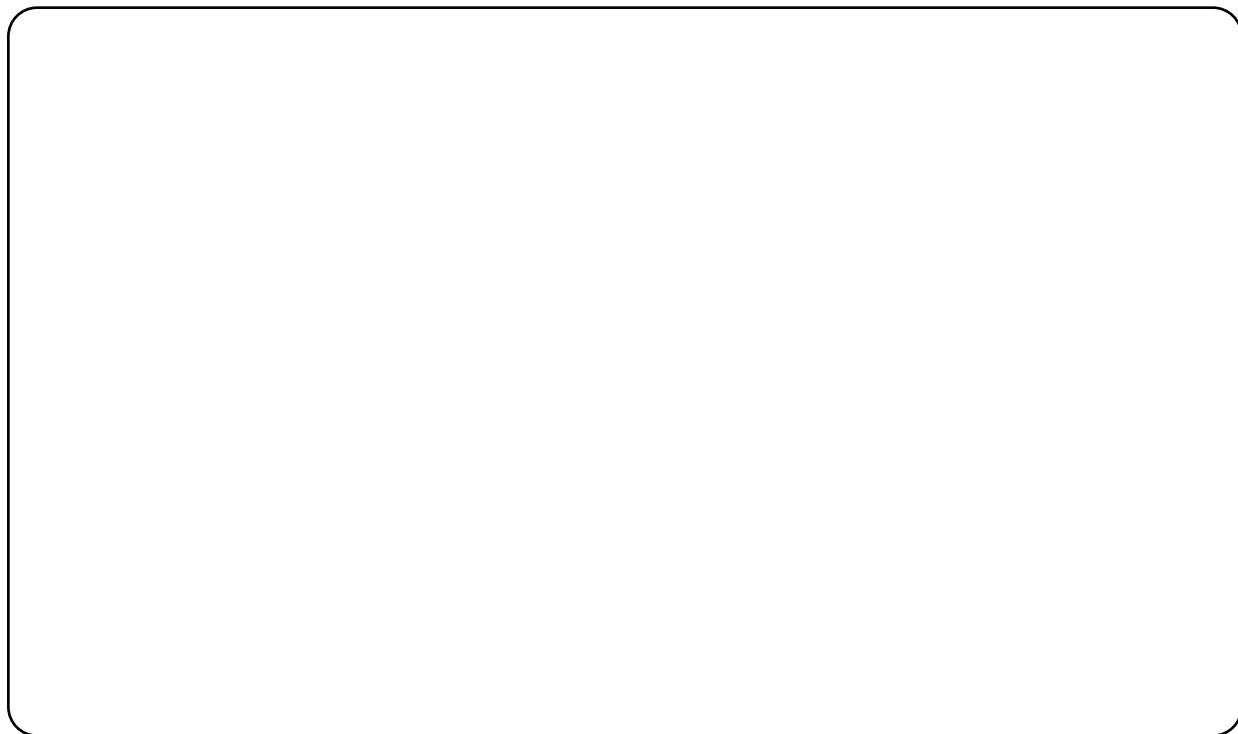

**Directions:** Draw a picture of where they went.

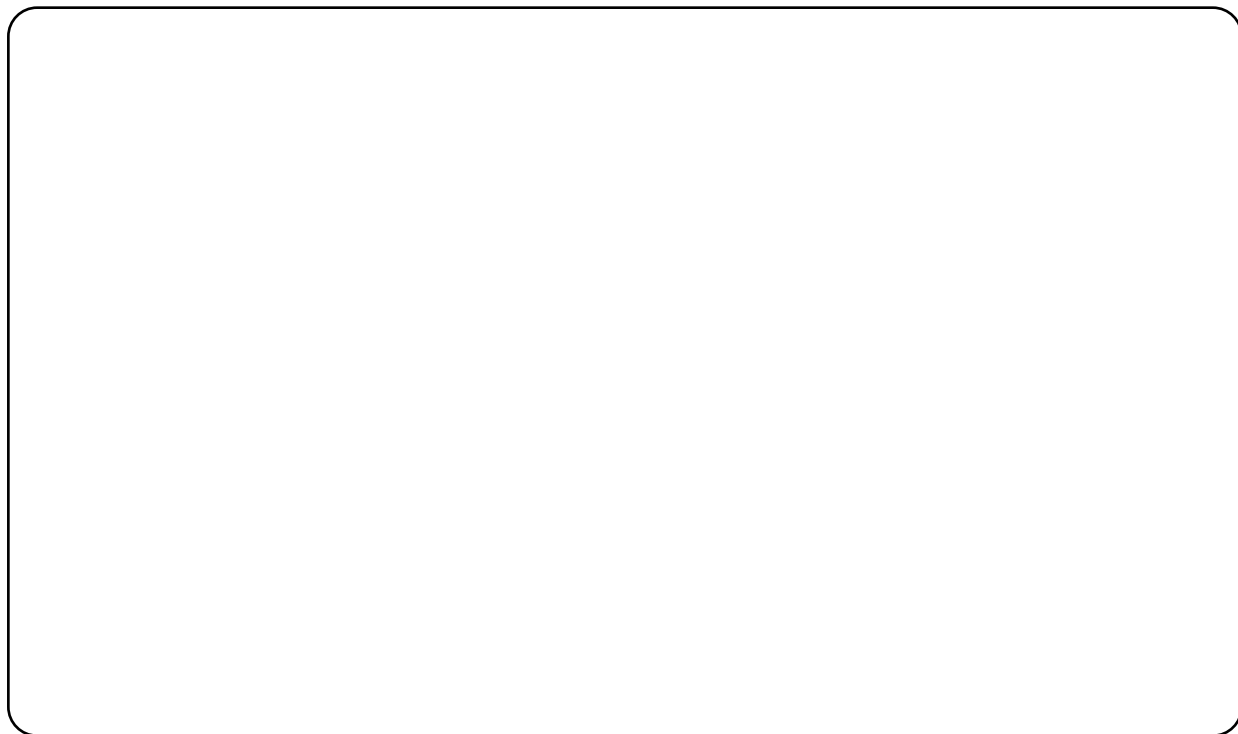

**Directions:** Draw a picture of the least favorite animal.

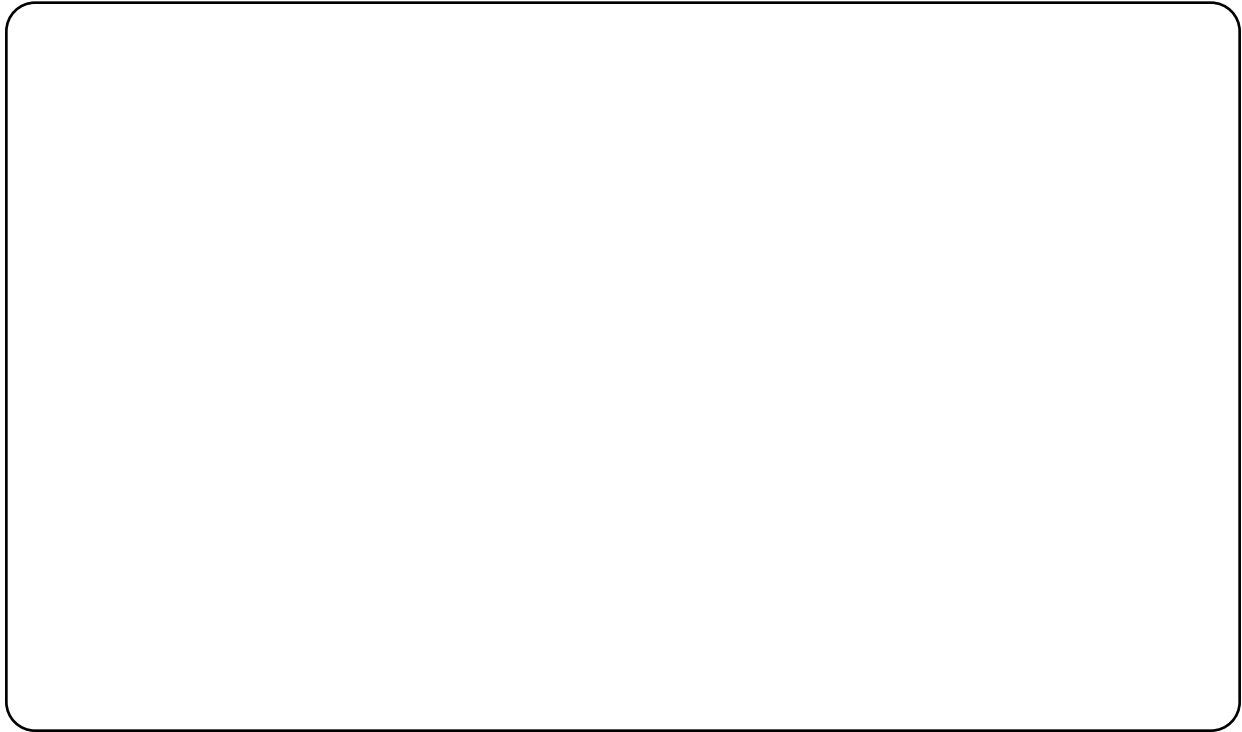





## Retelling a Story

**Directions:** Cut out the pages and put them in order. Staple the pages together. Then read the story and answer the questions.

### At the Zoo



by Nicole Mead

Name \_\_\_\_\_



We went to the zoo.

1

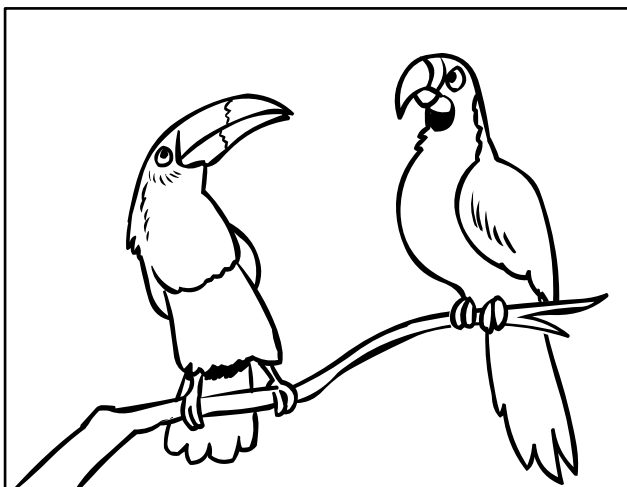

I saw lots of birds  
at the zoo.

2

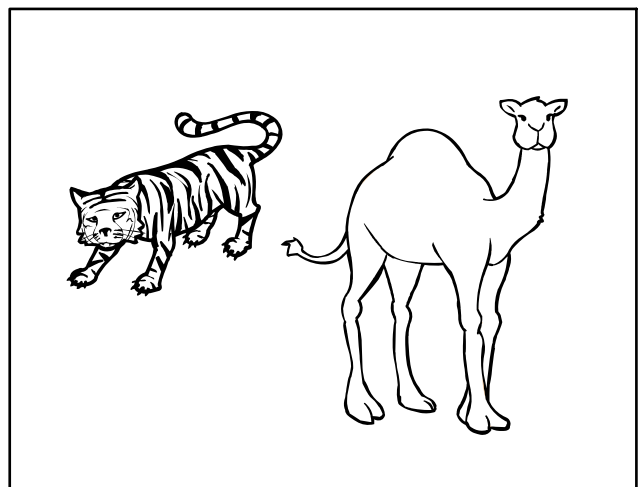

They saw camels  
and tigers at the zoo.

3

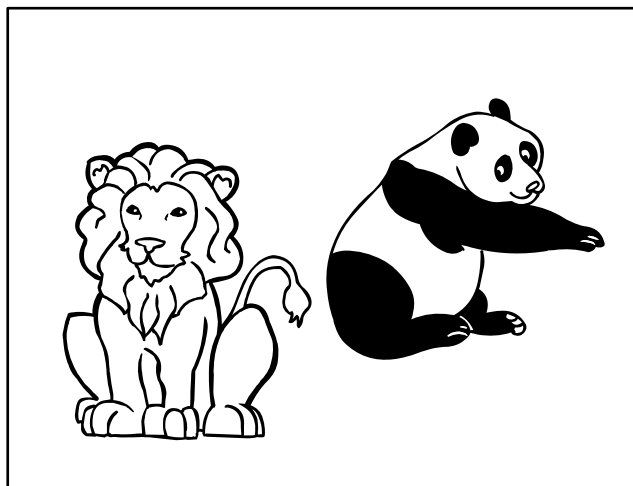

I saw lions and panda bears at the zoo.

4

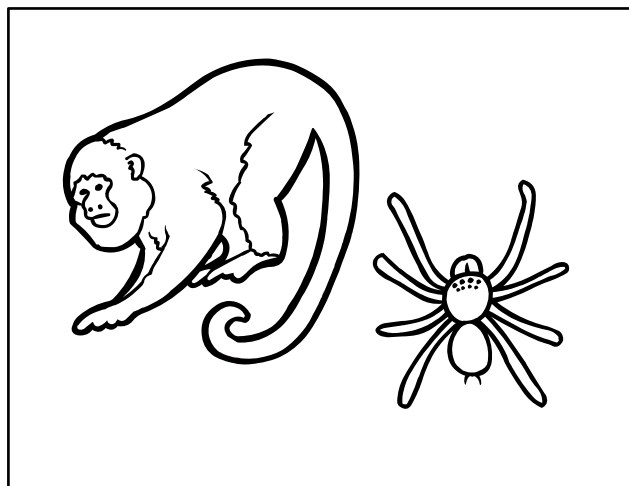

They saw monkeys and big spiders at the zoo!

5

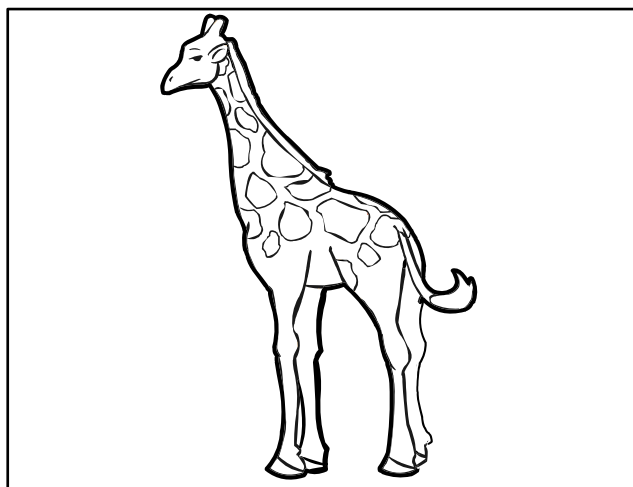

I saw the giraffe at the zoo.

6



They did not see the snakes at the zoo.

7

**Directions:** Draw a picture of who the story is about.



**Directions:** Draw a picture of where they went.

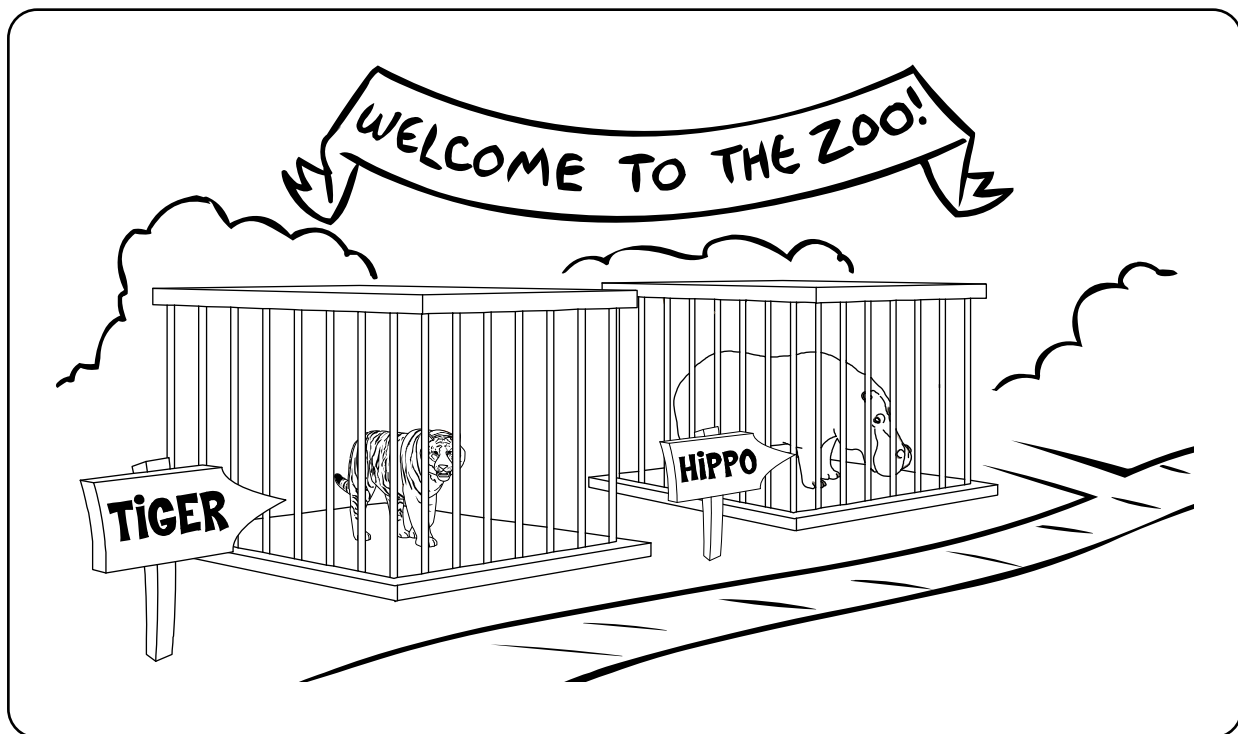

**Directions:** Draw a picture of the least favorite animal.

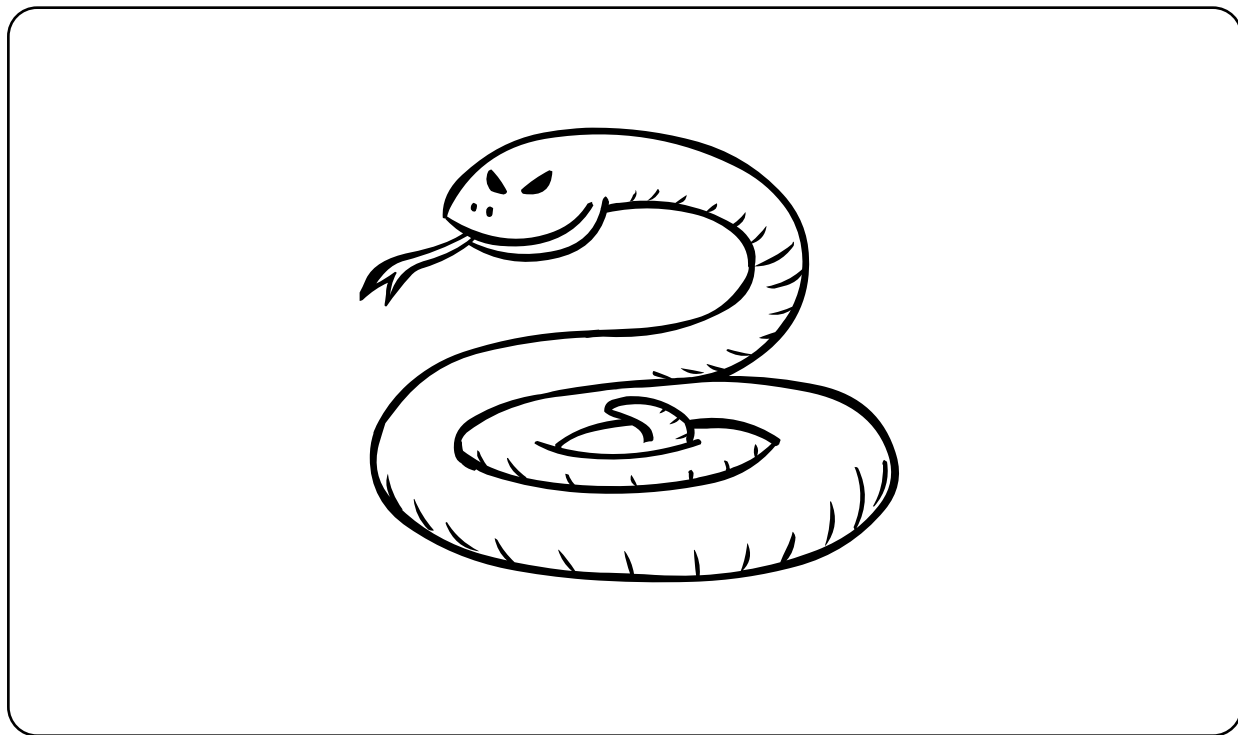

## aeiou Decoding Words

**Directions:** Look at the letters. Say each letter sound aloud.

m	s	f	e	t
o	p	x	r	z
d	h	i	k	qu
w	g	j	u	v

**Directions:** Cut out the puzzle. Say each sound as you build the puzzle. Blend the sounds together. Then read the word.

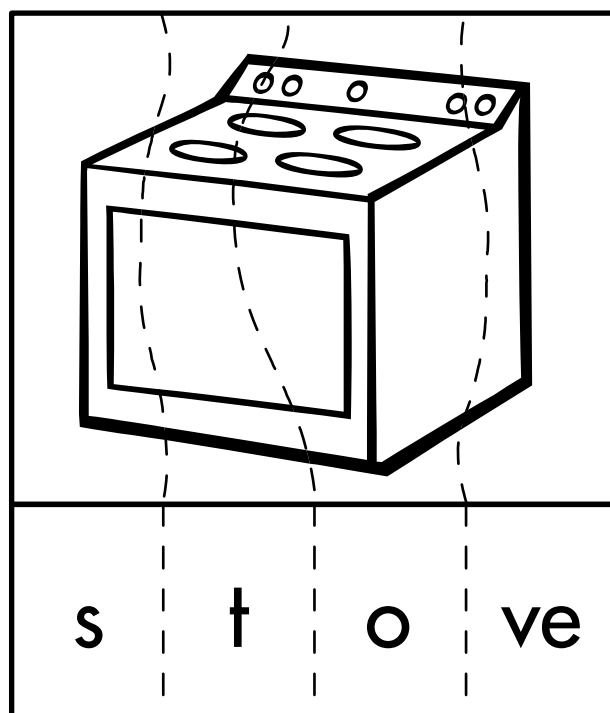
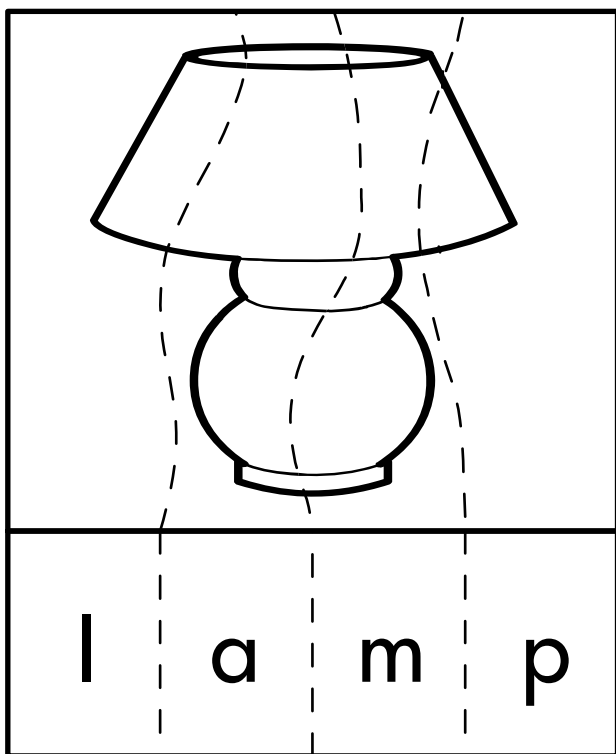

**Directions:** Cut out the puzzle. Say each sound as you build the puzzle. Blend the sounds together. Then read the word.

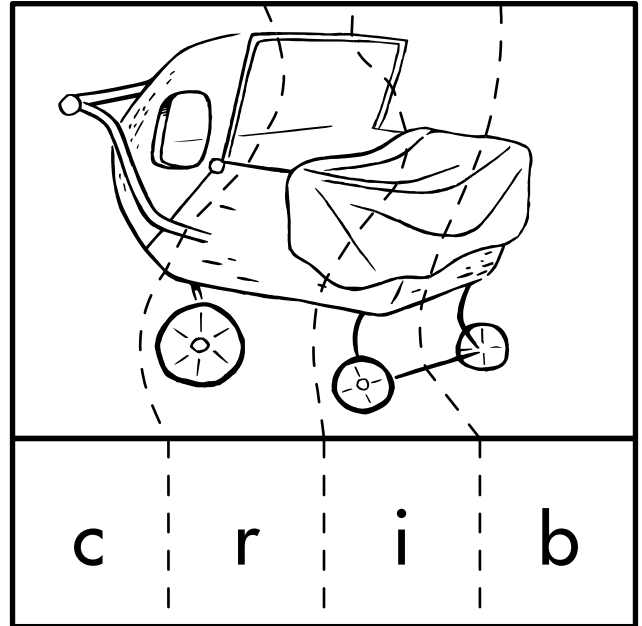
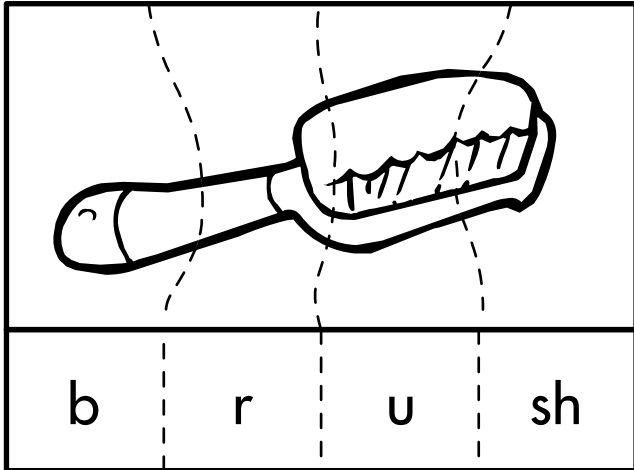

**Directions:** Cut out the pages and put them in order. Staple the pages together. Then read the story.

## It Is Hot!

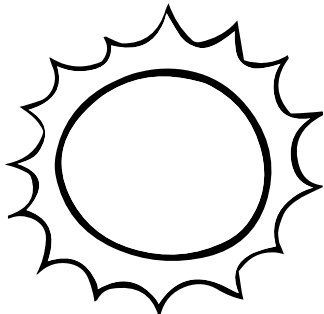

by Nicole Mead

Name \_\_\_\_\_

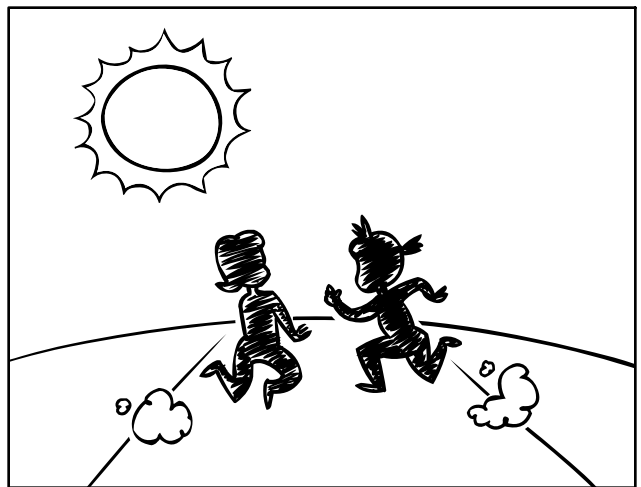

It is hot. It is  
hot in the sun.

1

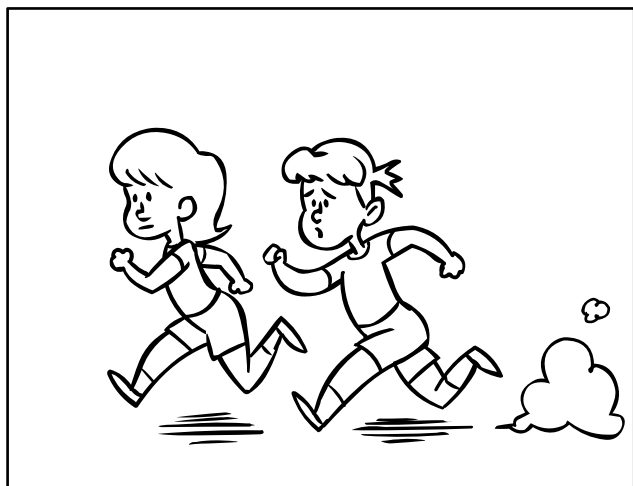

Kim and Pam run. They  
run in the hot sun. 2

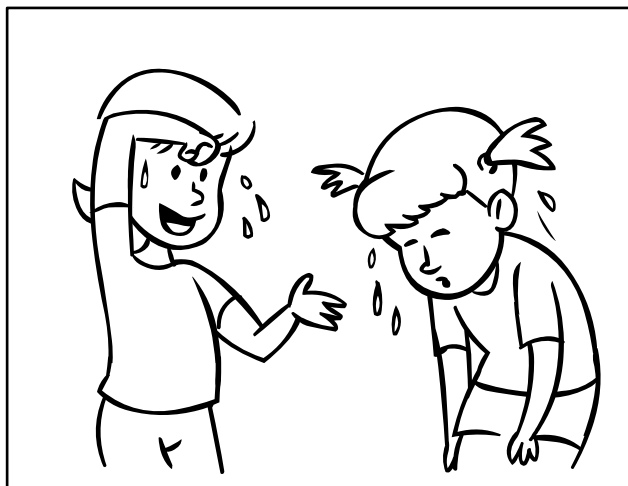

“I am hot!” 3

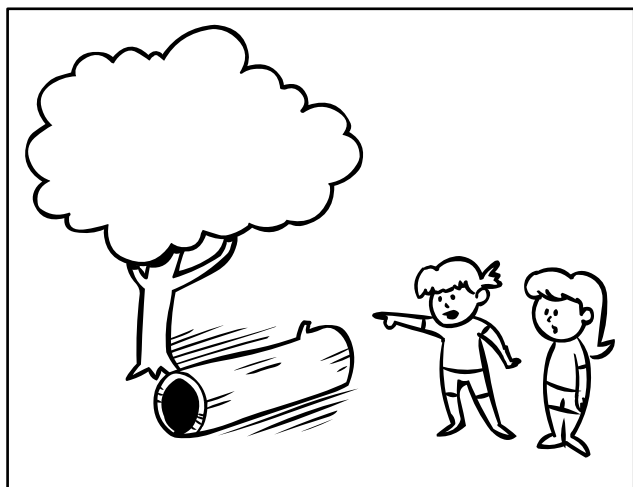

“Let’s sit on the log.” 4

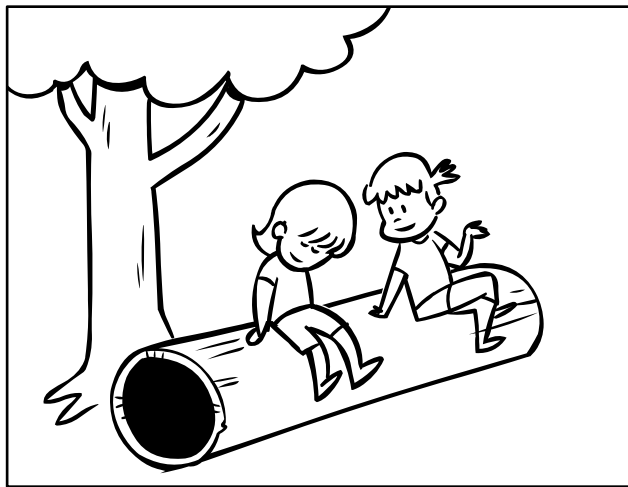

Kim and Pam sit. 5

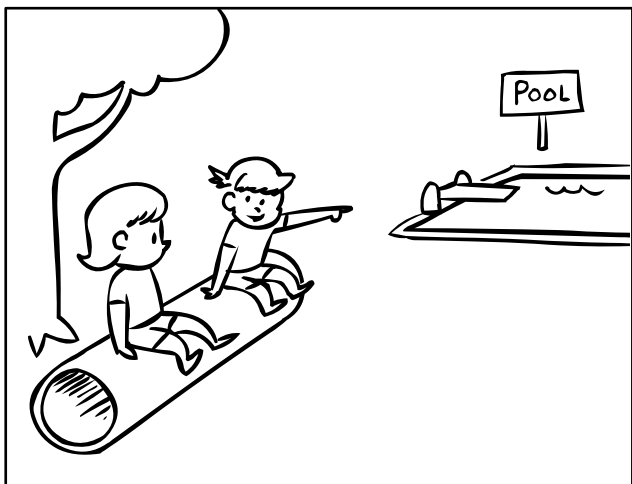

“Let’s take a dip.”

6

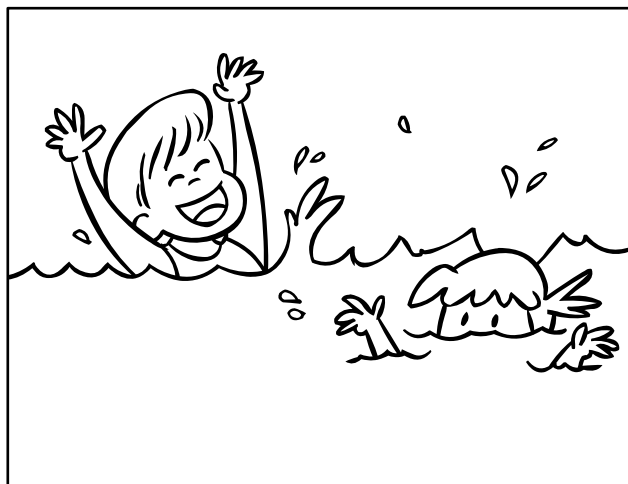

Kim and Pam get wet.

7

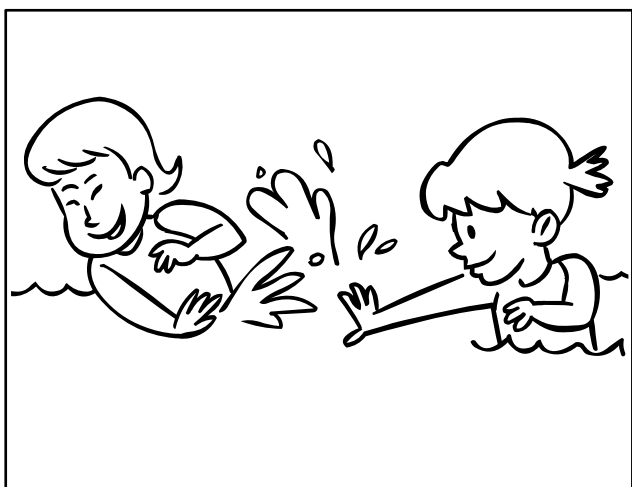

They get wet a lot.

8

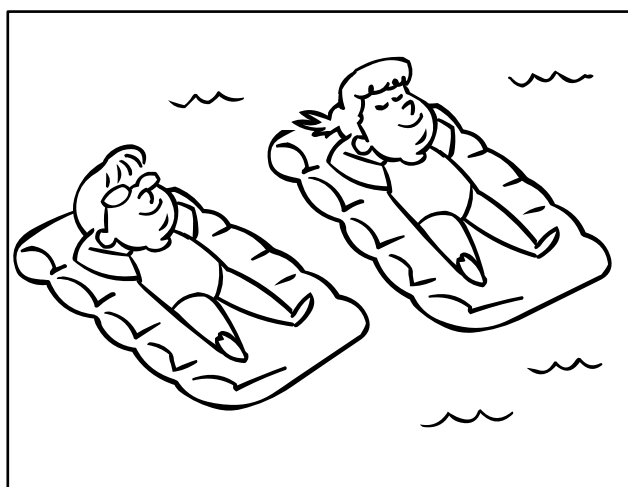

“I am not hot! I am not hot in the sun!”

9



## aeiou Decoding Words

**Directions:** Look at the letters. Say each letter sound aloud.

m	s	f	e	t
o	p	x	r	z
d	h	i	k	qu
w	g	j	u	v

**Directions:** Cut out the puzzle. Say each sound as you build the puzzle. Blend the sounds together. Then read the word.

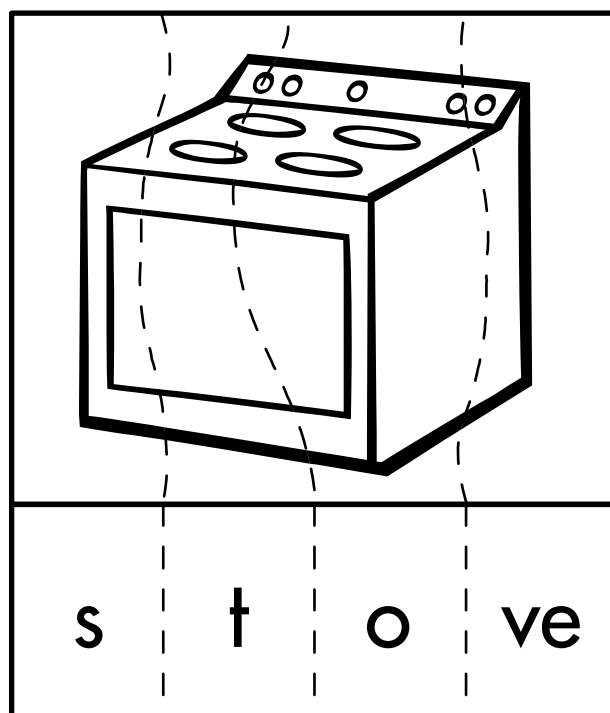
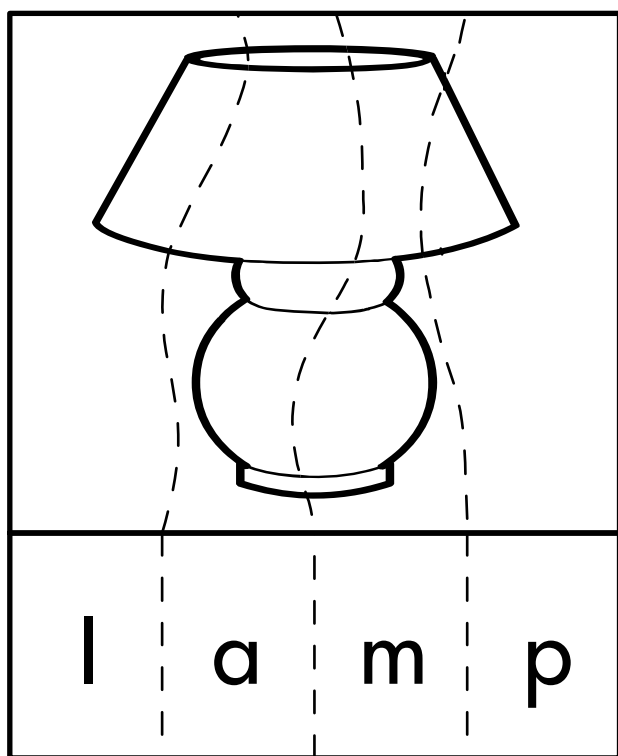

**Directions:** Cut out the puzzle. Say each sound as you build the puzzle. Blend the sounds together. Then read the word.

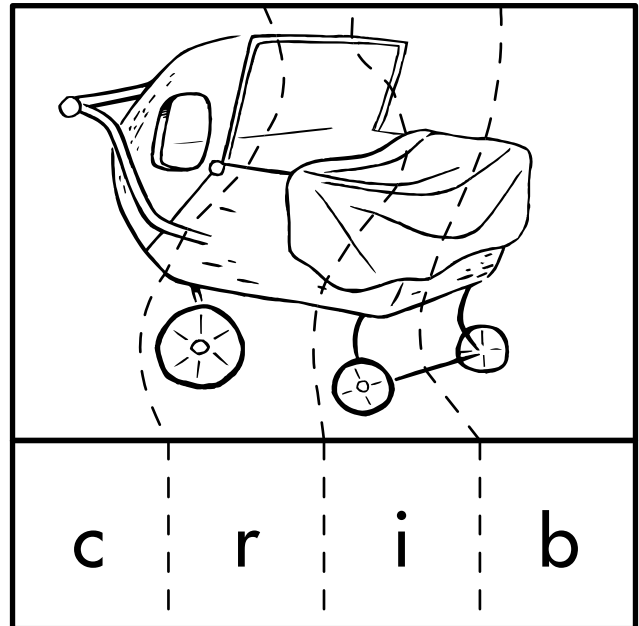
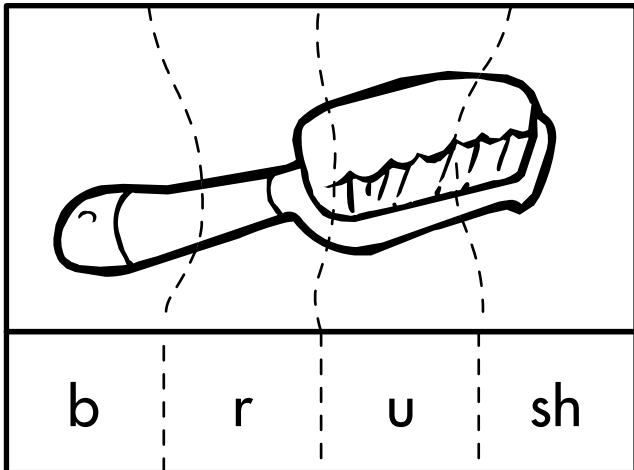

**Directions:** Cut out the pages and put them in order. Staple the pages together. Then read the story.

**It Is Hot!**

by Nicole Mead

Name \_\_\_\_\_

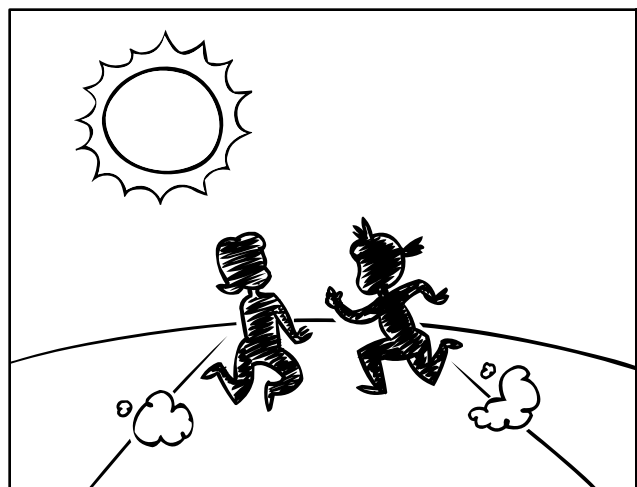

It is hot. It is  
hot in the sun.

1

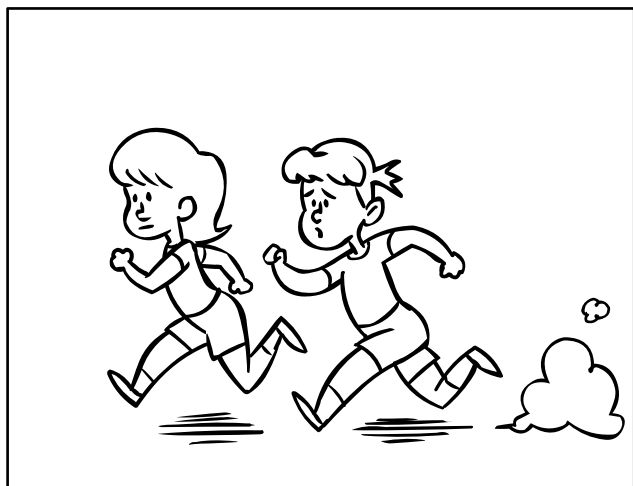

Kim and Pam run. They  
run in the hot sun.

2

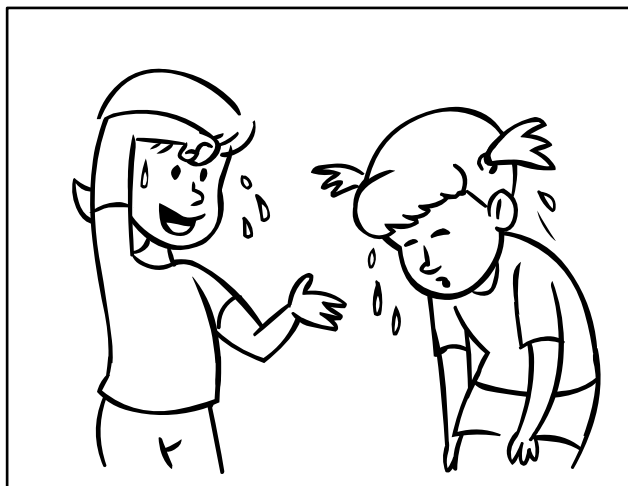

“I am hot!”

3

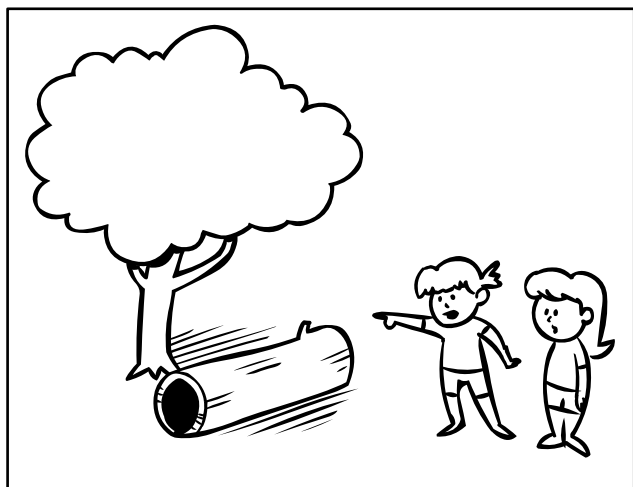

“Let’s sit on the log.”

4

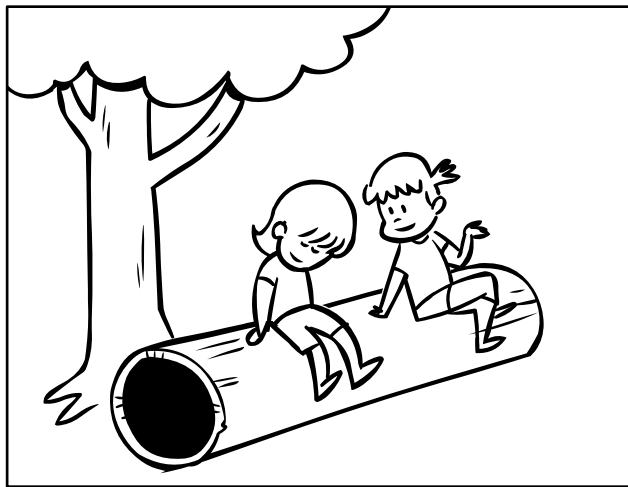

Kim and Pam sit.

5

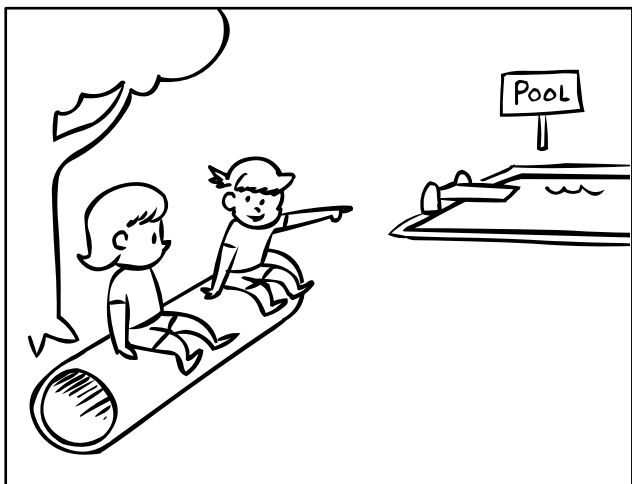

“Let’s take a dip.”

6

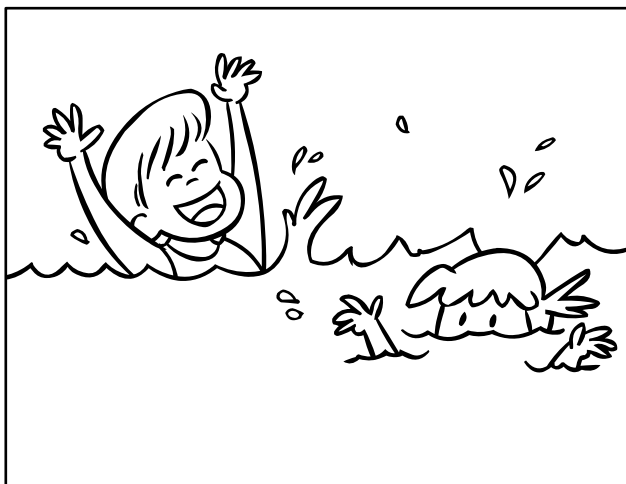

Kim and Pam get wet.

7

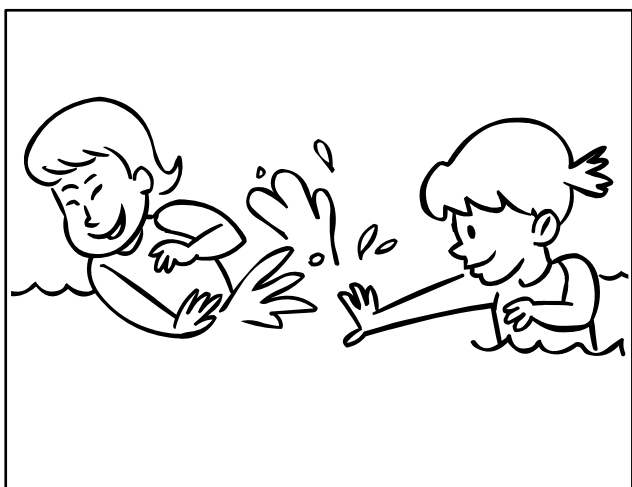

They get wet a lot.

8

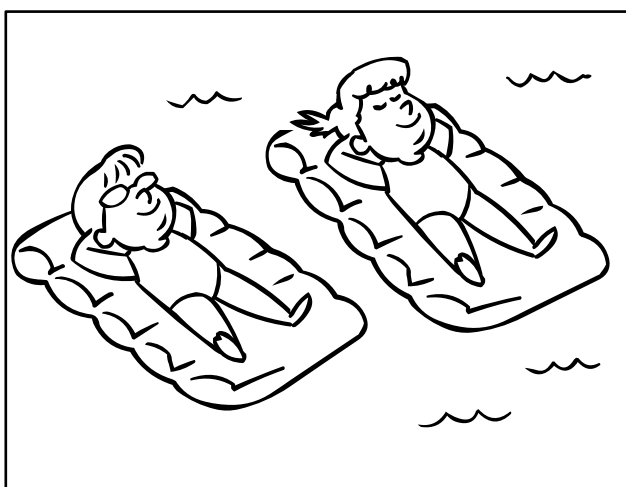

“I am not hot! I am not hot in the sun!”

9

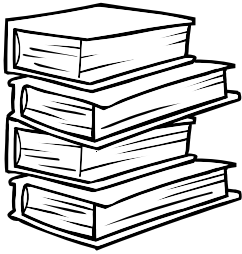

## Retelling a Story and Distinguishing Consonants and Vowels

**Directions:** Look at the letters. Then say each letter sound aloud.

m	qu	f	e	y
---	----	---	---	---

**Directions:** Look at the words. Then circle the vowels in the words.

hog	cap	the
are	on	

**Directions:** Read the sentences. Look for the words **I**, **at**, and **they**. Draw a ○ around the word **I**. Draw a □ around the word **at**. Underline the word **they**.

1. They are at the pig pen.
2. I am in the van.

**Directions:** Cut out the puzzle. Say each sound as you build the puzzle. Blend the sounds together. Then read the word.

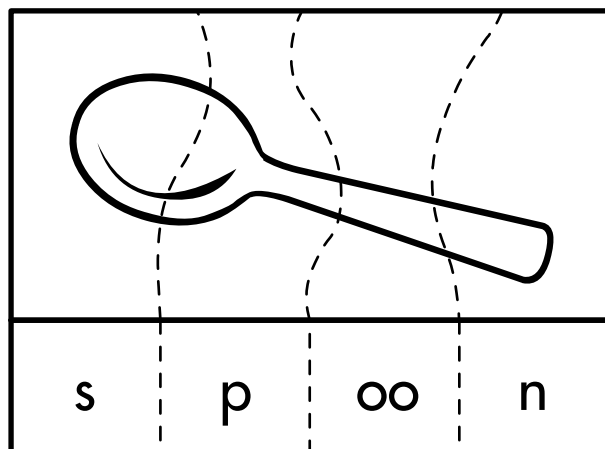
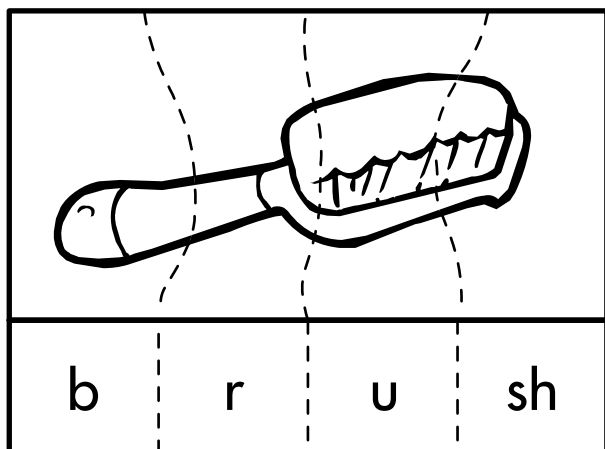

**Directions:** Look at the words below. Then read the story.

## Mag and Tim

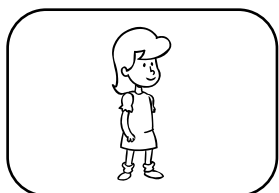

Mag

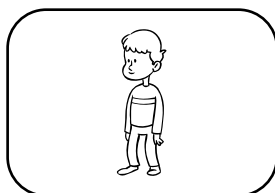

Tim

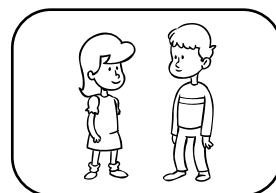

they

Mag and Tim put the  away.  
cup

Mag and Tim put the  away.  
plate

Mag and Tim put the  and  away.  
spoon fork

Where do they put the ?  
mug

Do they put it with the ?  
mop

No! Do they put it with the ?  
pan

No! Mag and Tim put it with the !  
cup

**Directions:** Draw pictures to answer the questions.

**Who?**

**Where?**

**What?**



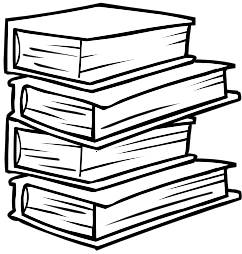

## Retelling a Story and Distinguishing Consonants and Vowels

**Directions:** Look at the letters. Then say each letter sound aloud.

m	qu	f	e	y
---	----	---	---	---

**Directions:** Look at the words. Then circle the vowels in the words.

h <u>o</u> g	c <u>a</u> p	th <u>e</u>
a <u>r</u> e	o <u>n</u>	

**Directions:** Read the sentences. Look for the words **I**, **at**, and **they**. Draw a  around the word **I**. Draw a  around the word **at**. Underline the word **they**.

1. They are  at the pig pen.

2.  I am in the van.

**Directions:** Cut out the puzzle. Say each sound as you build the puzzle. Blend the sounds together. Then read the word.

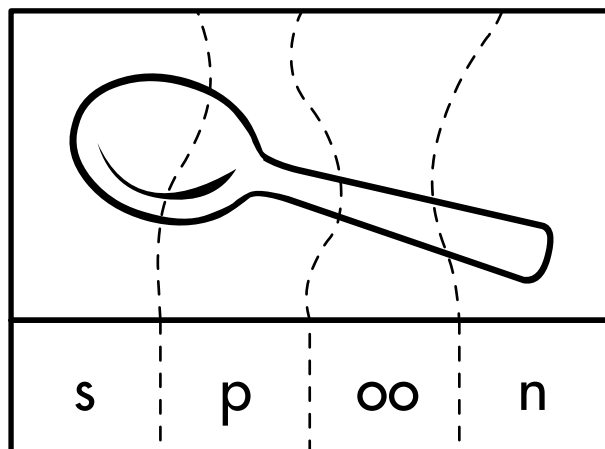
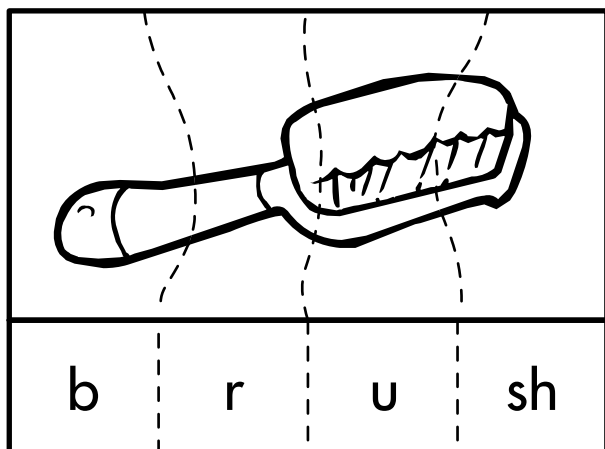

**Directions:** Look at the words below. Then read the story.

## Mag and Tim

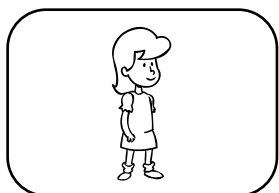

Mag

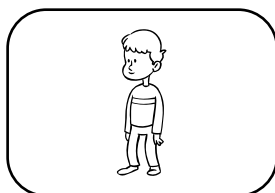

Tim

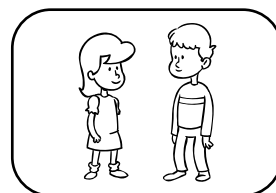

they

Mag and Tim put the  away.  
cup

Mag and Tim put the  away.  
plate

Mag and Tim put the  and  away.  
spoon fork

Where do they put the ?  
mug

Do they put it with the ?  
mop

No! Do they put it with the ?  
pan

No! Mag and Tim put it with the !  
cup

**Directions:** Draw pictures to answer the questions.

**Who?**

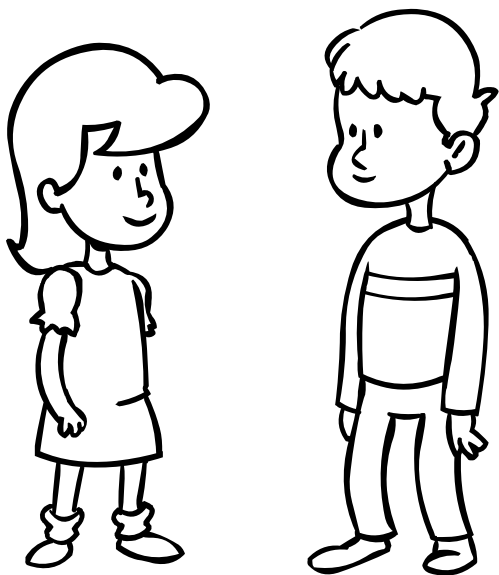

**Where?**



**What?**

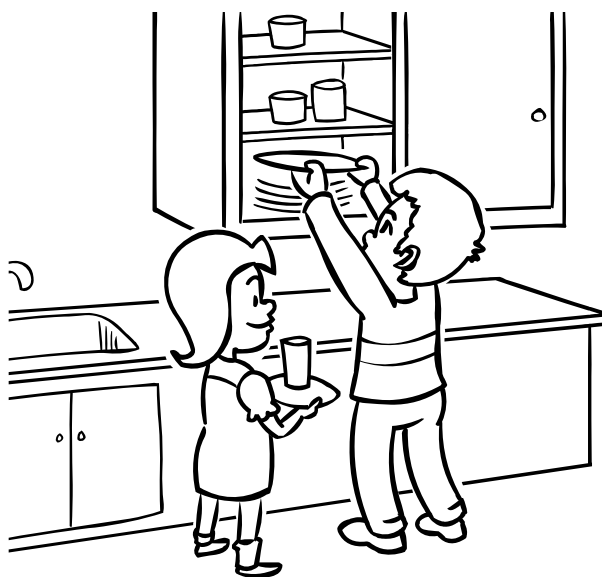

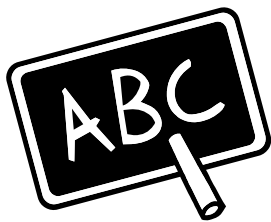

## Distinguishing Long and Short Vowel Sounds

**Directions:** For each row, say the name of each picture aloud. Then color the picture that has the same vowel sound as the first picture.

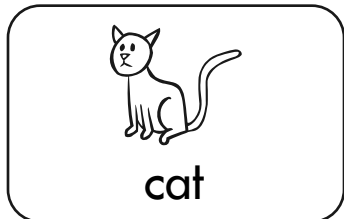

cake

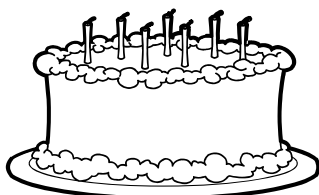

bat

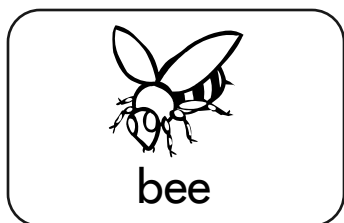

feet

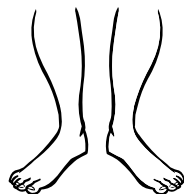

jet

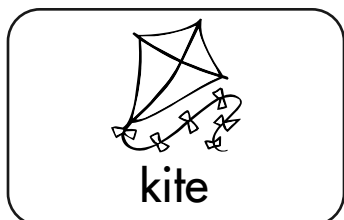
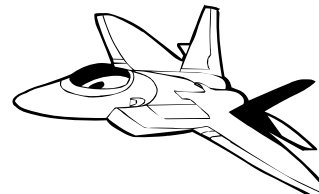

kid



bike

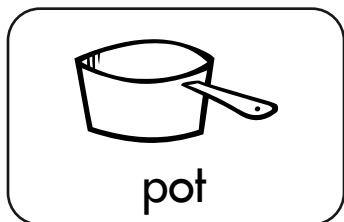

bone

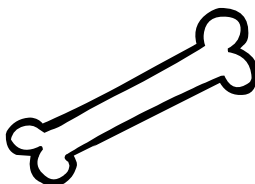

dog

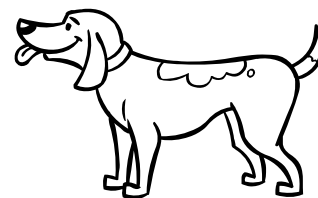

bug



cube

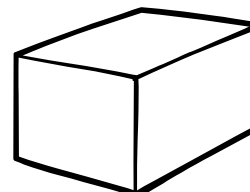

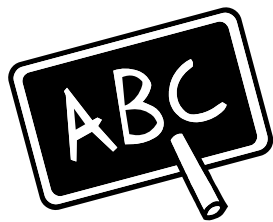

## Distinguishing Long and Short Vowel Sounds

**Directions:** For each row, say the name of each picture aloud. Then color the picture that has the same vowel sound as the first picture.

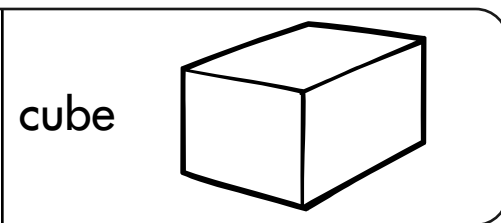
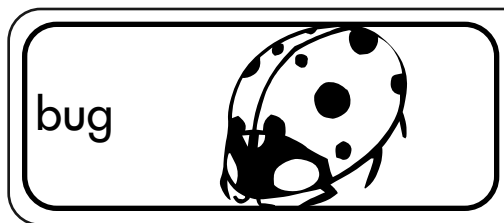
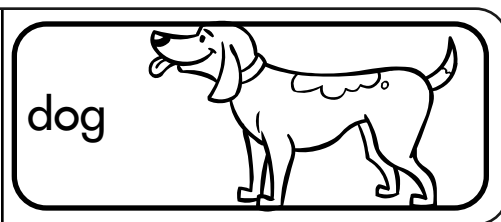
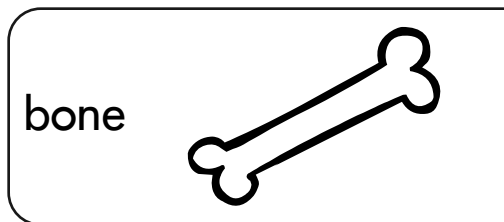
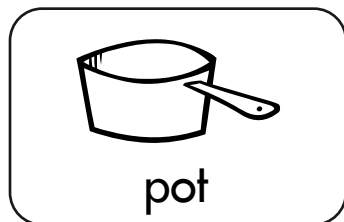
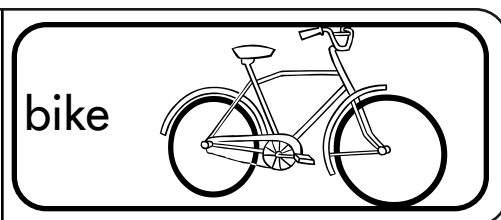
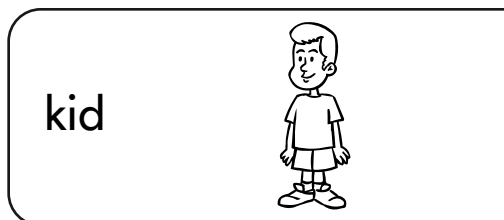
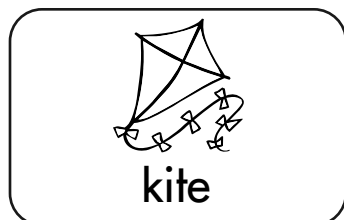
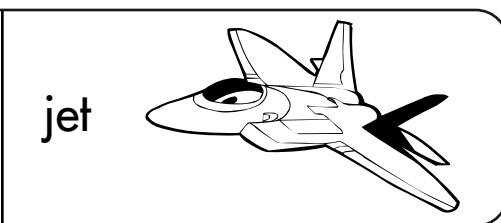
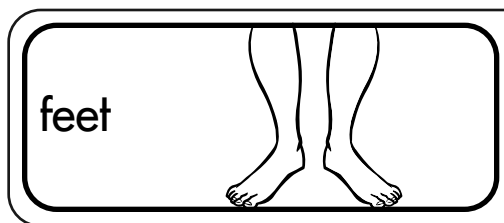
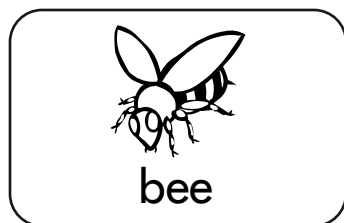
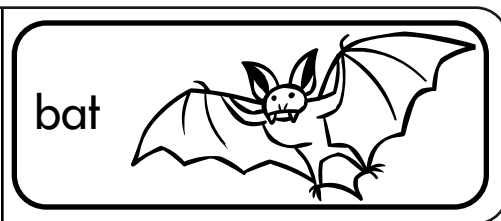
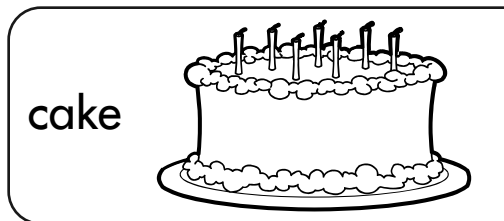
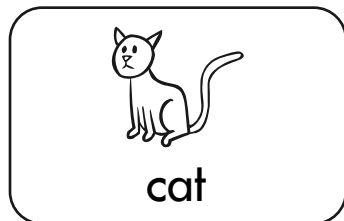

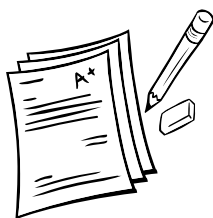

## Identifying the Correct Sequence of Events

**Directions:** Cut out the pictures. Then paste them in the boxes in the correct order.

1.

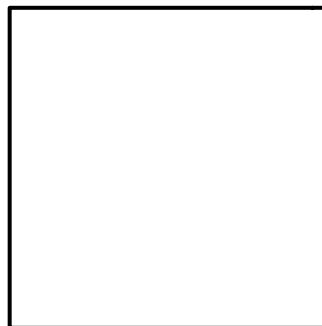
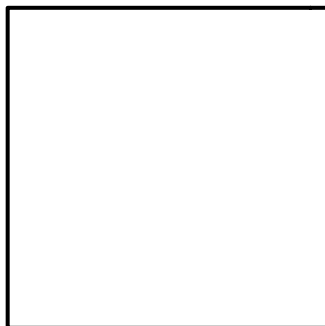
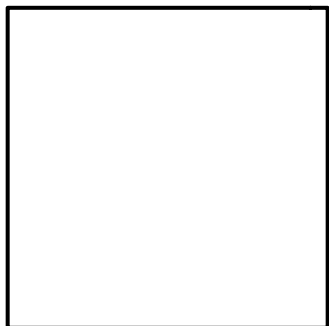

2.

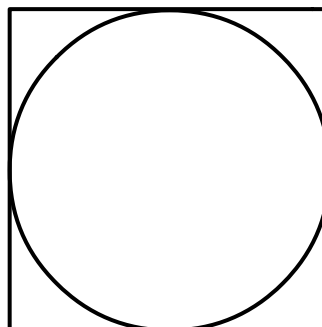
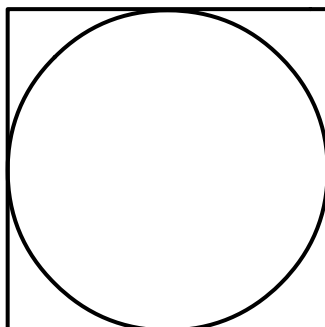
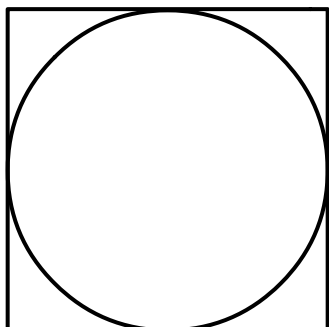

3.

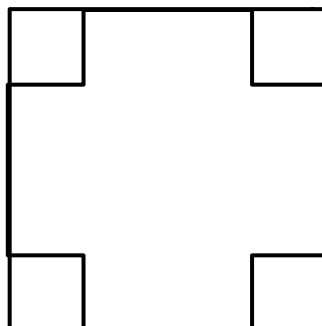
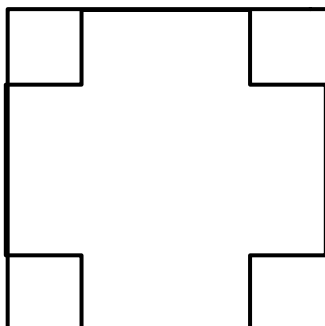
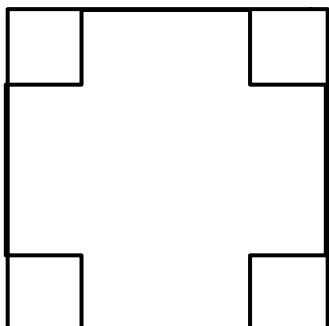

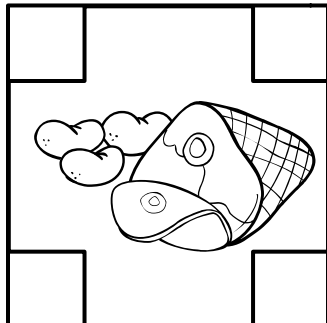
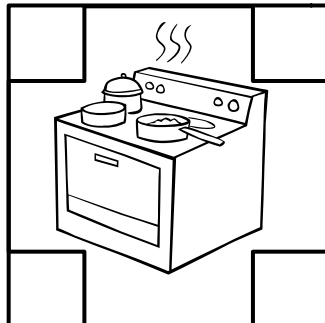
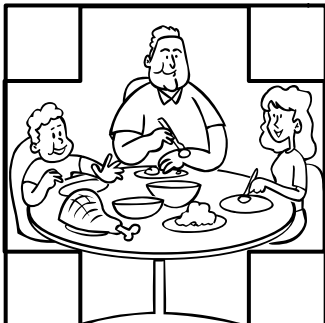
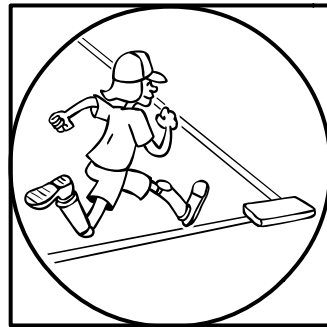
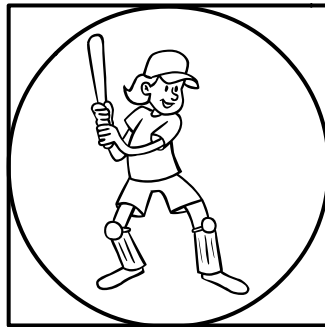
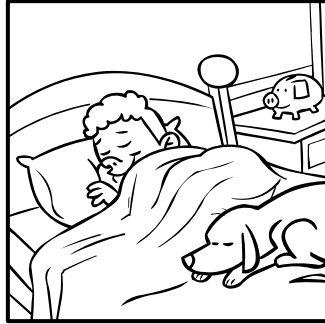





## Identifying the Correct Sequence of Events

**Directions:** Cut out the pictures. Then paste them in the boxes in the correct order.

1.



2.

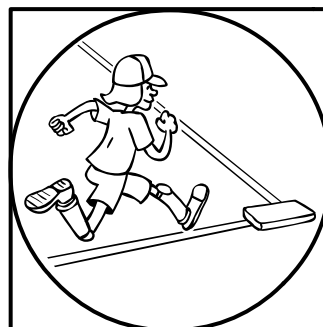
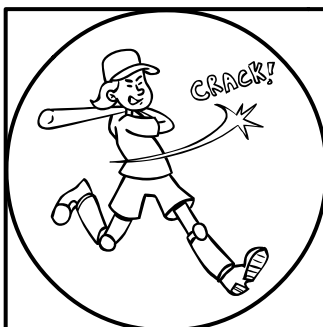
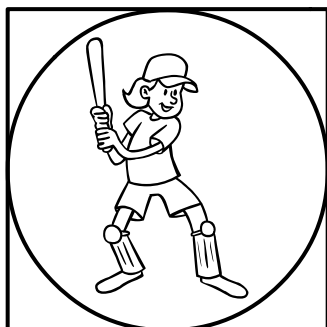

3.

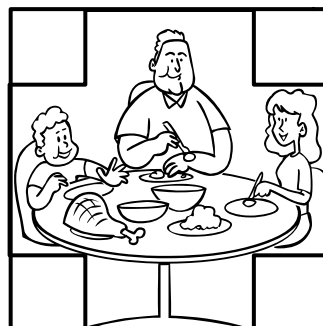
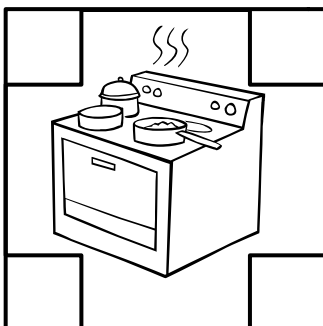
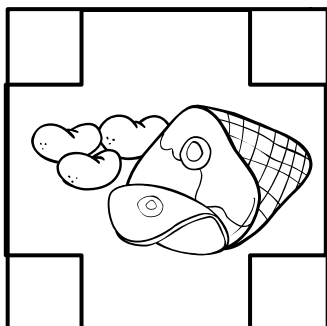

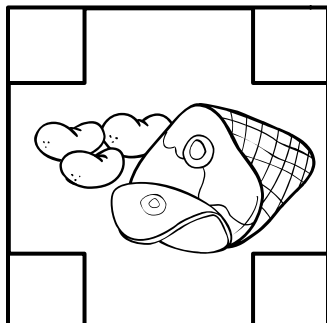
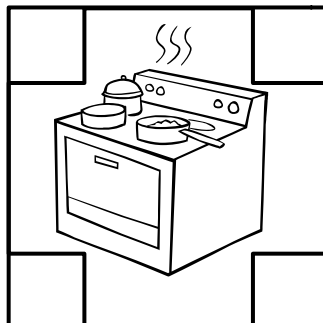
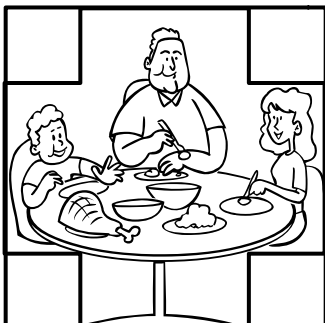
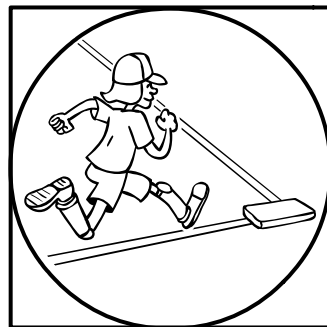
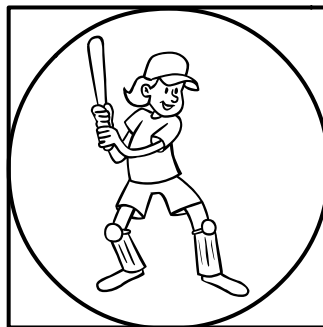
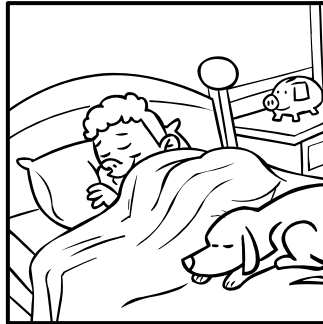

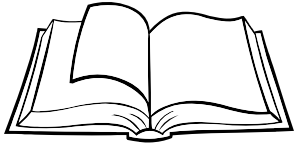







## Reading High Frequency Words

**Directions:** Read the story.

This is  . This is  .  
Matt Ann

 and  have a  .  and  have a  .  
Matt Ann cat Matt Ann dog

 gets the  . They will be on the  .  
Matt cat bed

 gets the  . They will be on the  .  
Ann dog rug

They are one big family.

**Directions:** Draw pictures to answer the questions.

Who?







Where?





## Reading High Frequency Words

**Directions:** Read the story.

This is  . This is  .  
Matt Ann

 and  have a  .  and  have a  .  
Matt Ann cat Matt Ann dog

 gets the  . They will be on the  .  
Matt cat bed

 gets the  . They will be on the  .  
Ann dog rug

They are one big family.

**Directions:** Draw pictures to answer the questions.

Who?



Where?

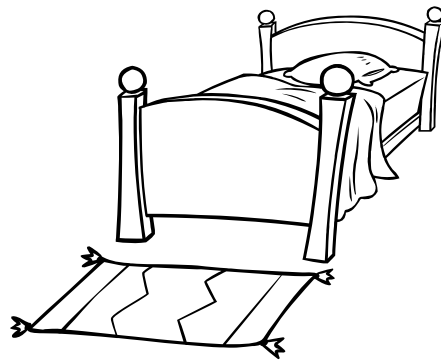

## aeiou

### Comparing and Contrasting

**Directions:** In each circle, color the things that are alike.

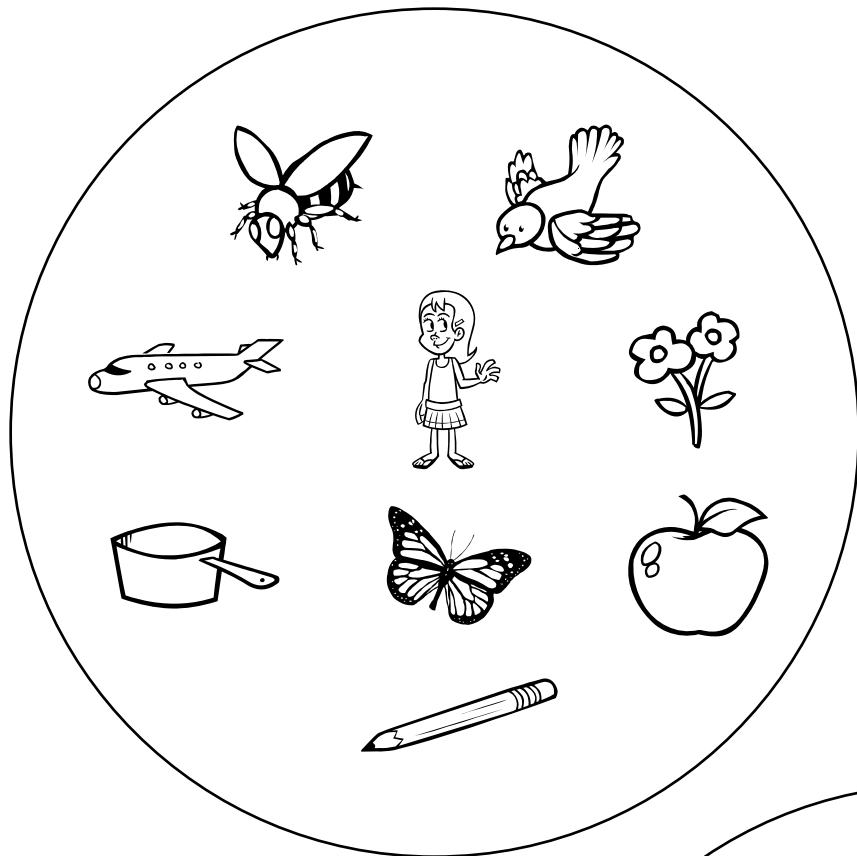

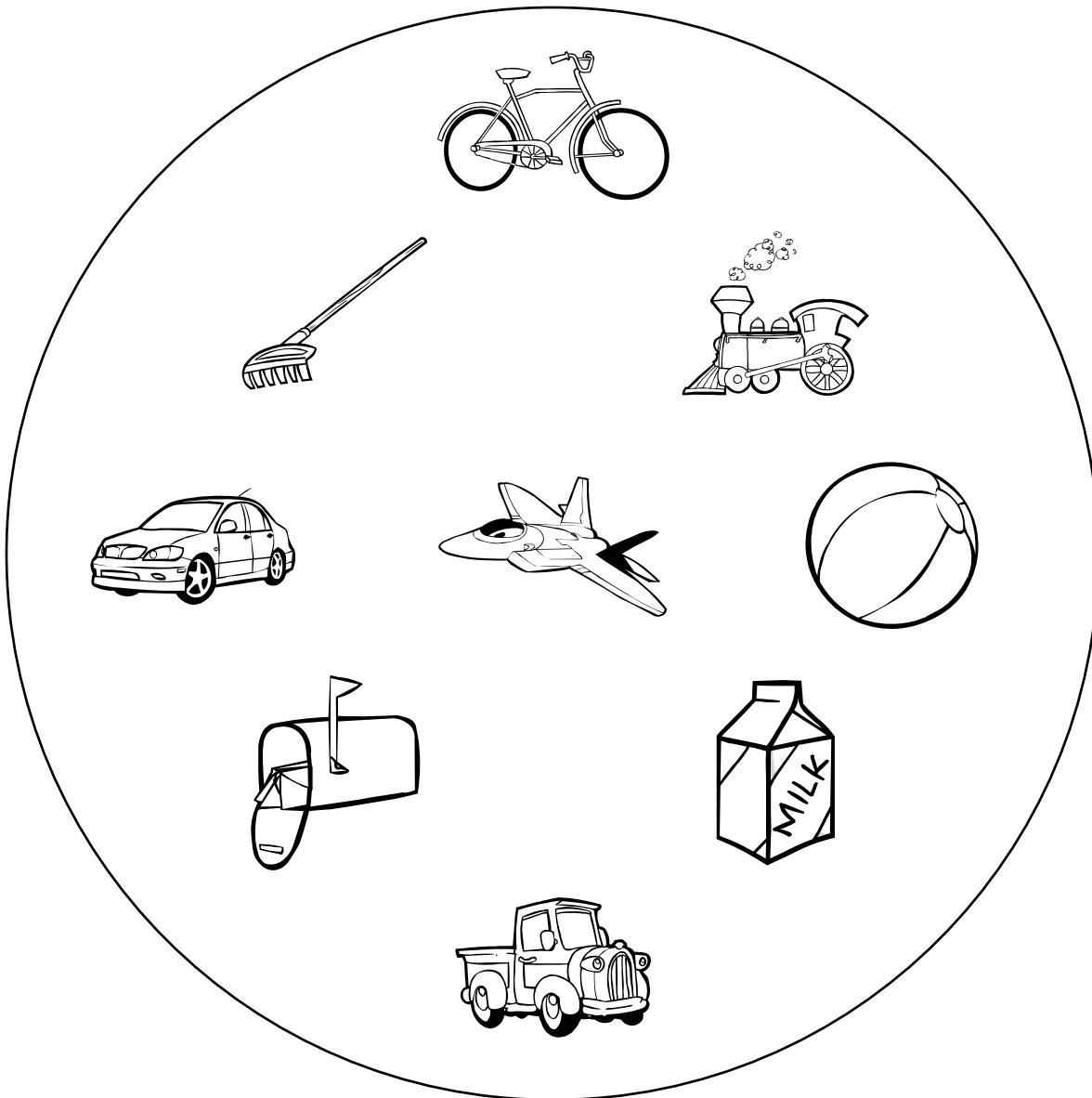

## aeiou

### Comparing and Contrasting

**Directions:** In each circle, color the things that are alike.

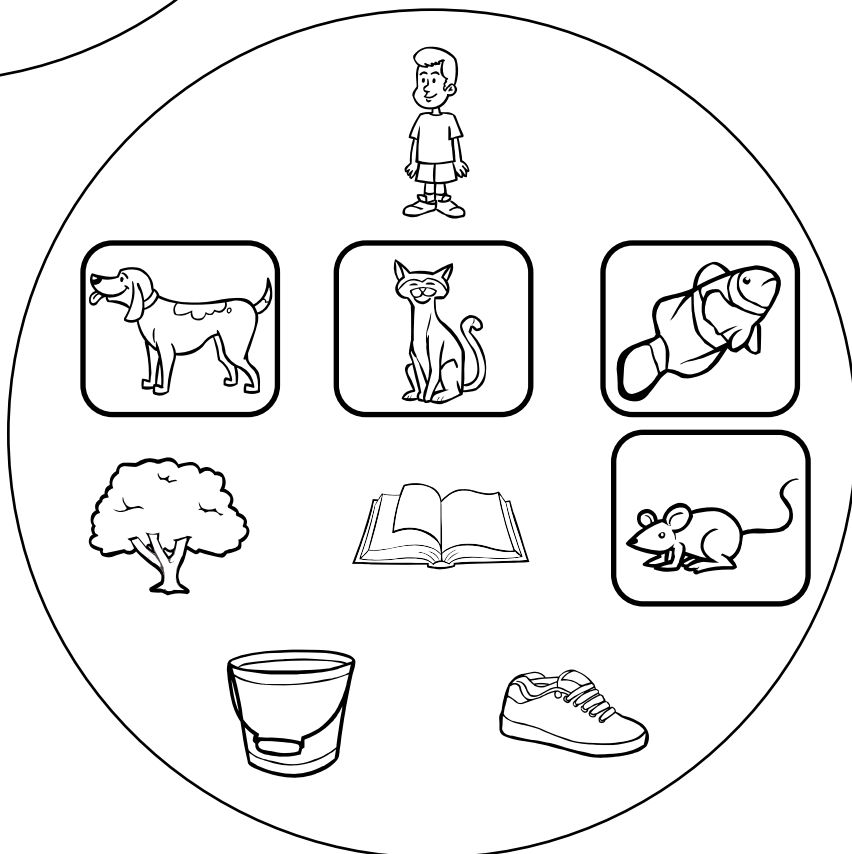
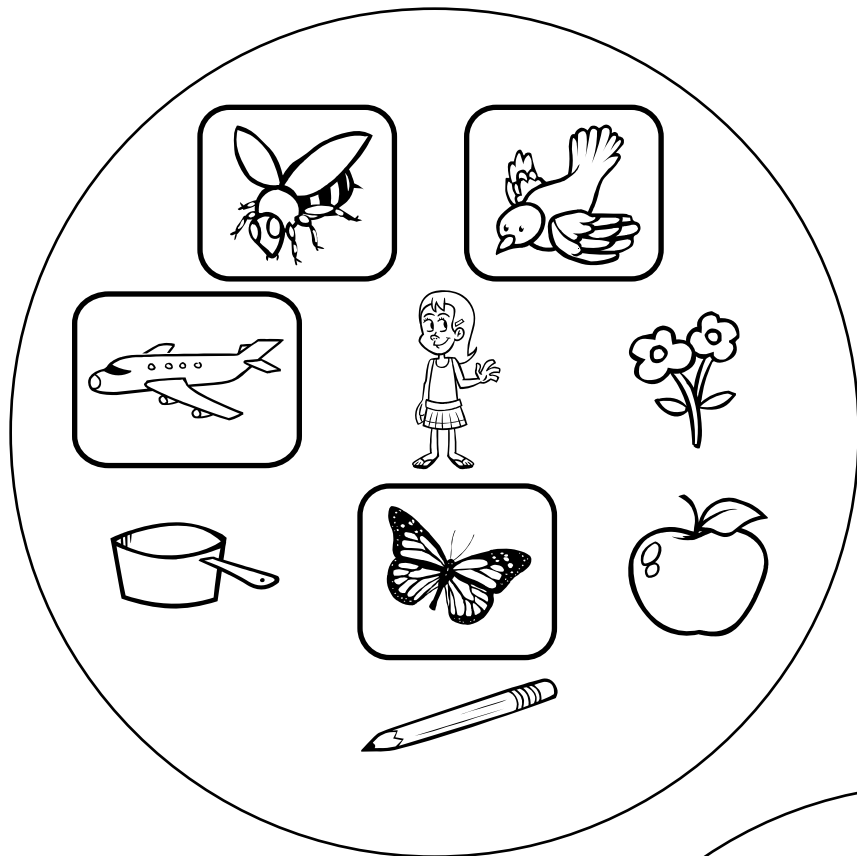

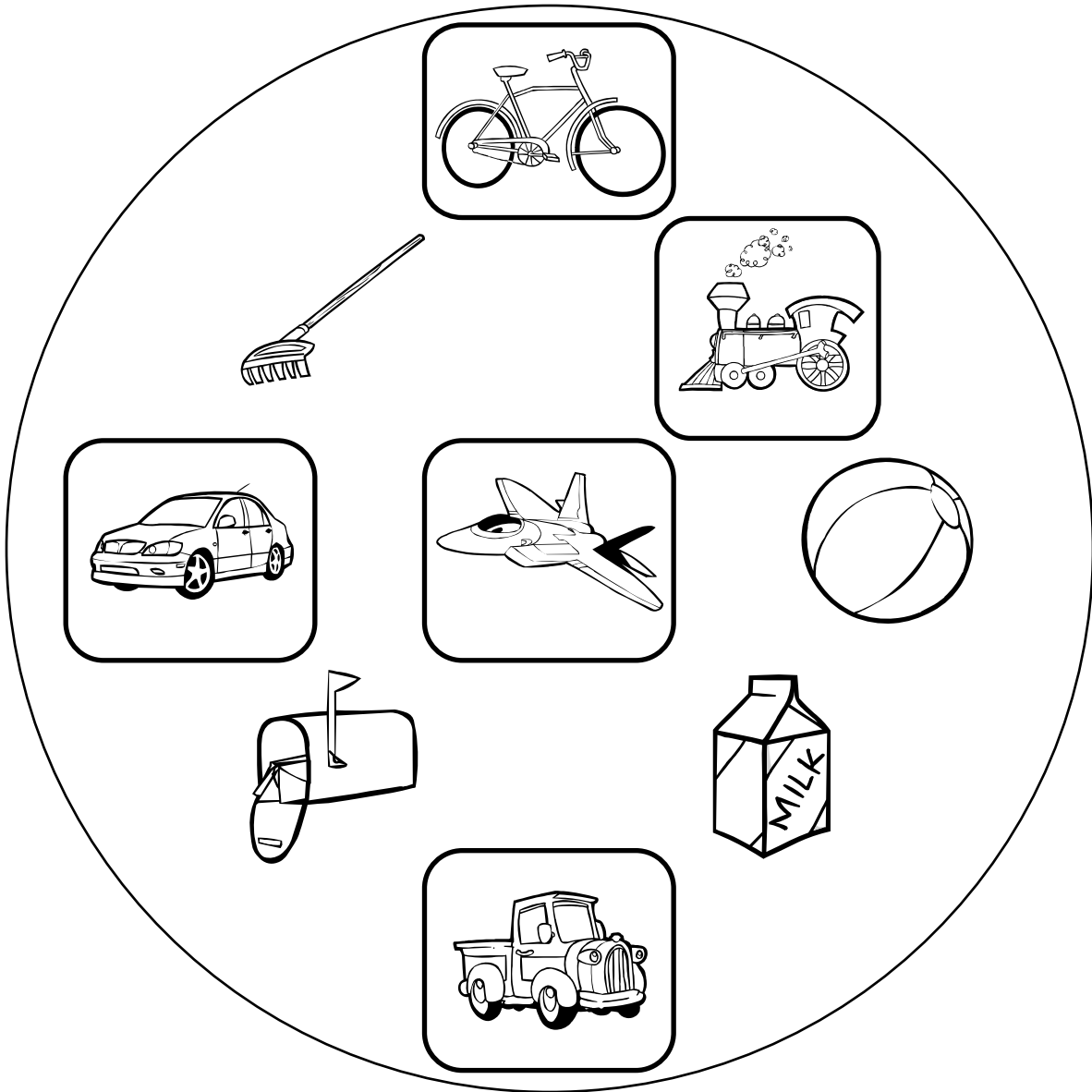



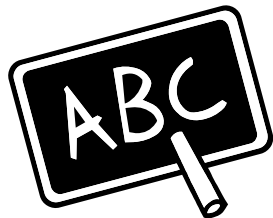

## Blending CVCC and CCVC Words

**Directions:** Read the sentences. Then cut out the pictures. Paste each one below the sentence it matches.

1. I swim like a fish.

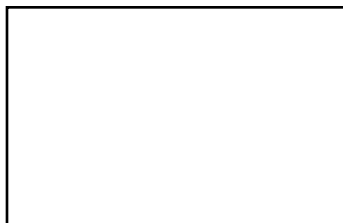

5. Do not drop the flag.

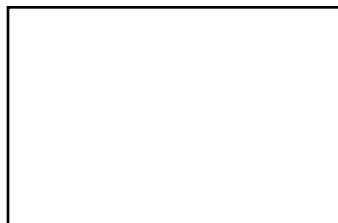

2. Sit at my desk.



6. We went on a trip.



3. This is Sam's gift.



7. Grab my hand!



4. The duck sat in its nest.



8. I can snap and clap.



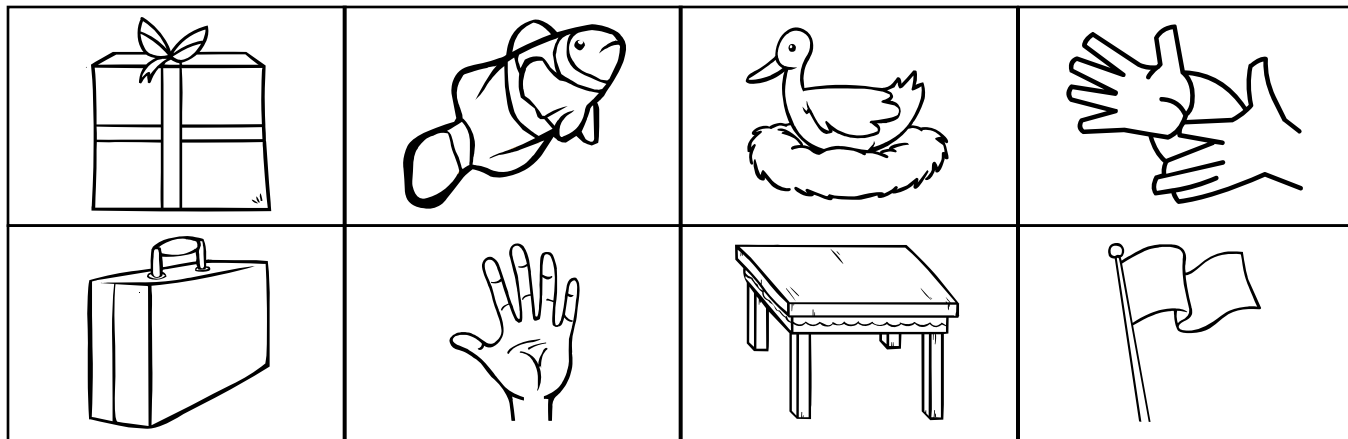

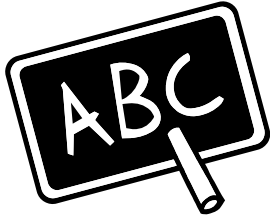

## Blending CVCC and CCVC Words

**Directions:** Read the sentences. Then cut out the pictures. Paste each one below the sentence it matches.

1. I swim like a fish.

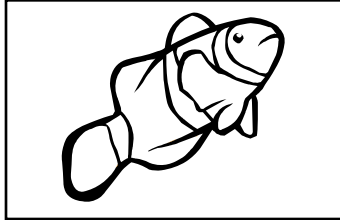

5. Do not drop the flag.

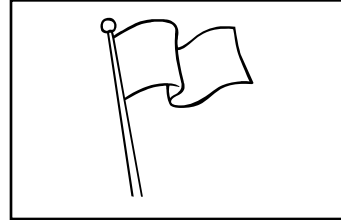

2. Sit at my desk.

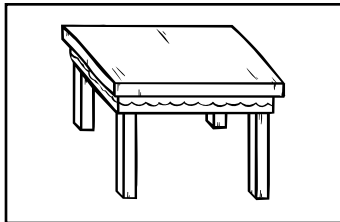

6. We went on a trip.

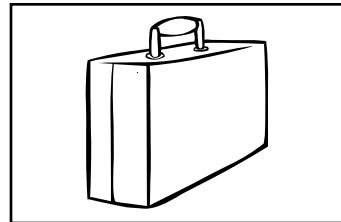

3. This is Sam's gift.



7. Grab my hand!

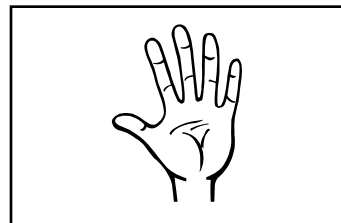

4. The duck sat in its nest.

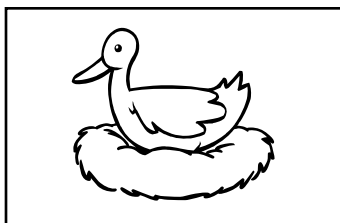

8. I can snap and clap.

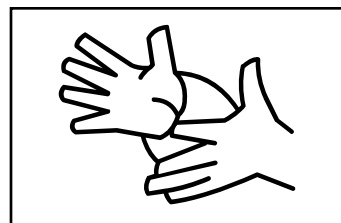

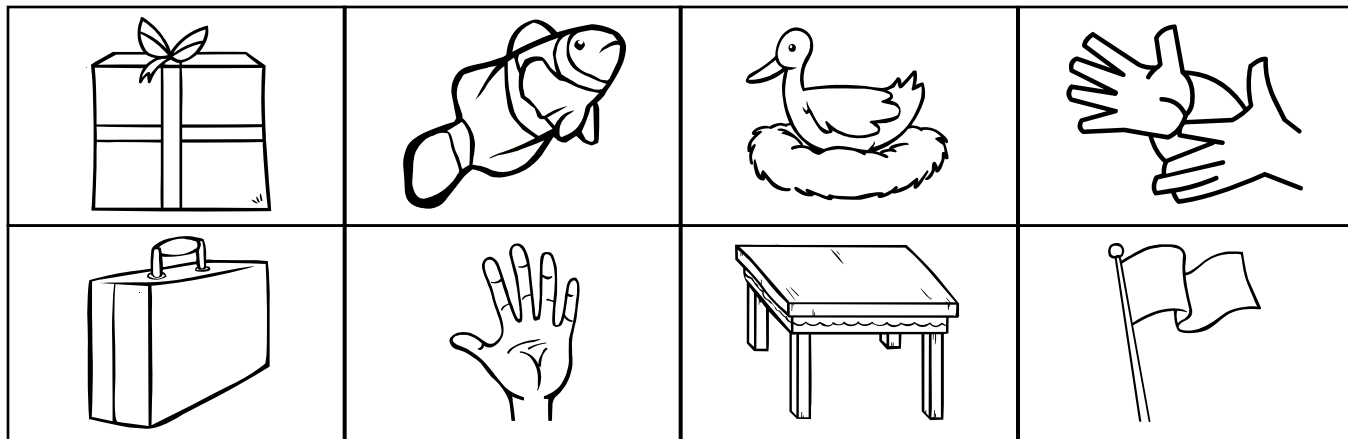

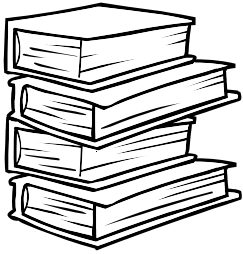

## Blending CVCC and CCVC and Reading High Frequency Words

**Directions:** For each row, say the name of each picture aloud. Then color the picture that has the same vowel sound as the first picture.

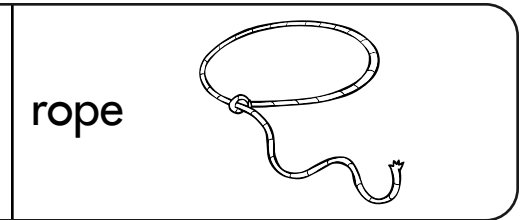
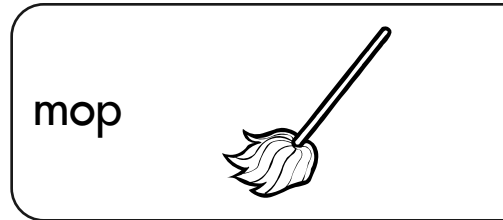
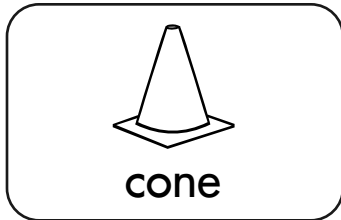
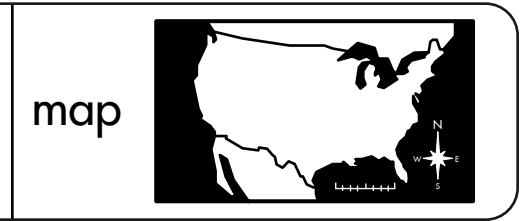
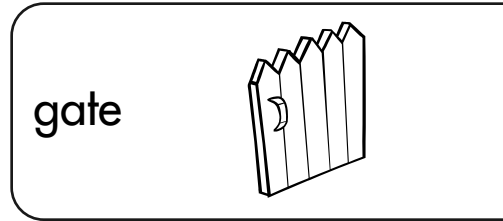
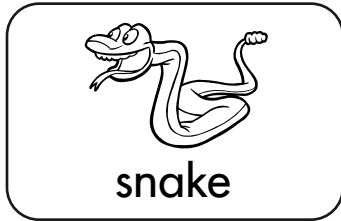

**Directions:** Draw an X on the picture that is out of order.

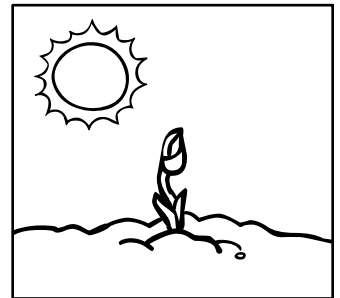
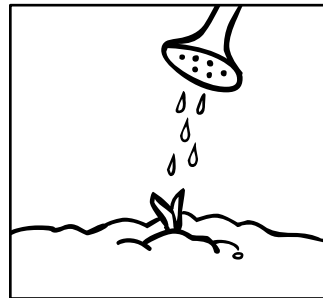
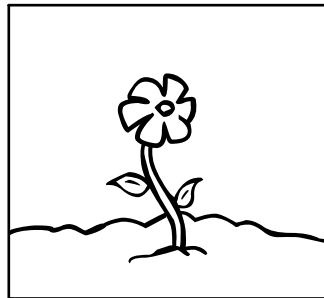
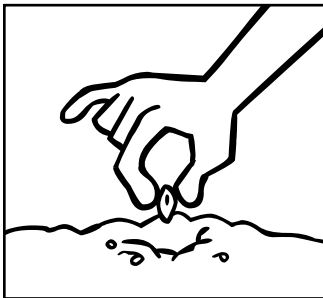

**Directions:** Read the sentences. Underline the words **this**, **be**, and **have**.

This must be the cat.

I have a dog.

You can be it.

**Directions:** Circle the pictures that are alike.

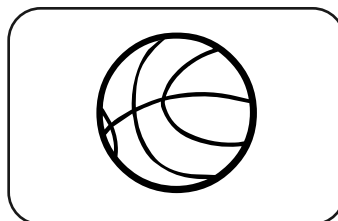
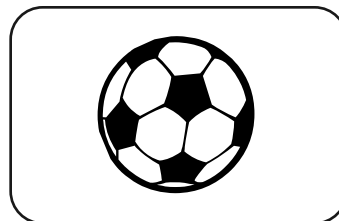
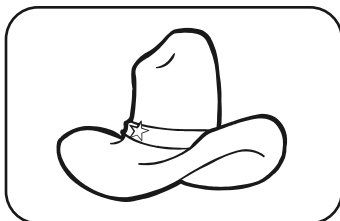
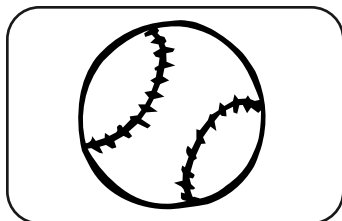

**Directions:** Draw a line to match the sentence with the picture.

I have a frog.

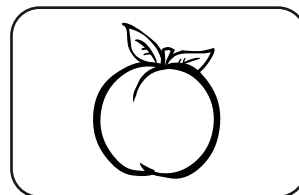

Nan is hot.

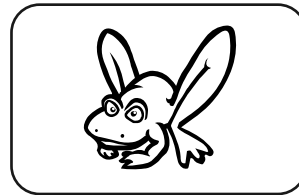

Bob had a plum.

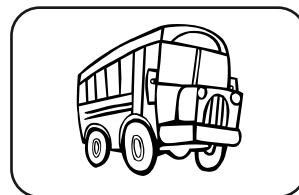

The bus is big.

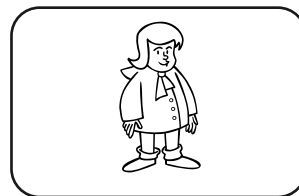

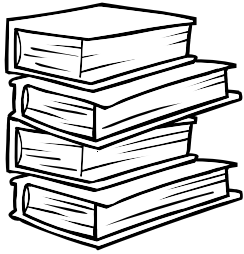

## Blending CVCC and CCVC and Reading High Frequency Words

**Directions:** For each row, say the name of each picture aloud. Then color the picture that has the same vowel sound as the first picture.

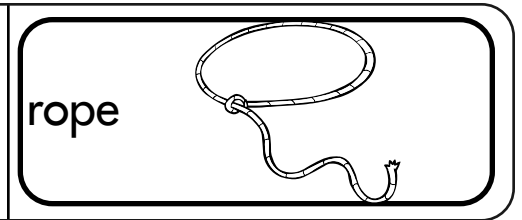
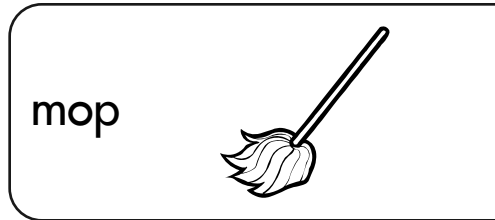
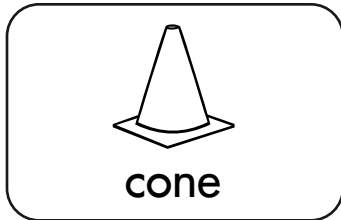
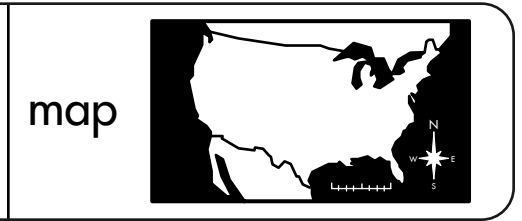
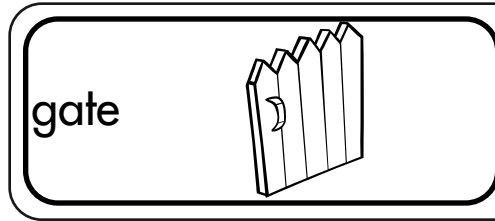
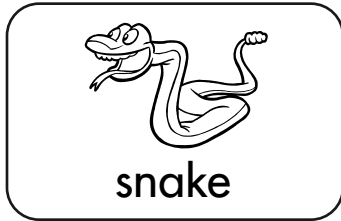

**Directions:** Draw an X on the picture that is out of order.

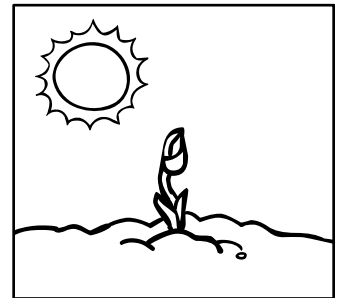
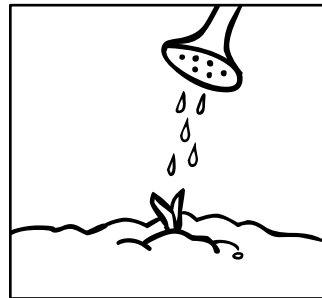
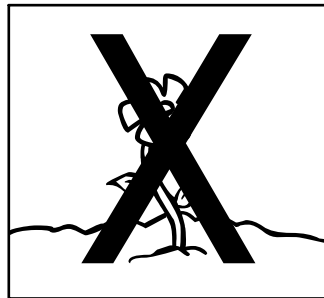
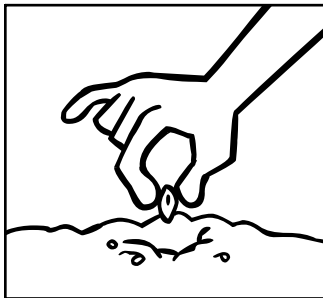

**Directions:** Read the sentences. Underline the words **this**, **be**, and **have**.

This must be the cat.

I have a dog.

You can be it.

**Directions:** Circle the pictures that are alike.

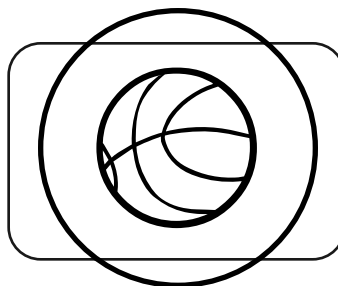
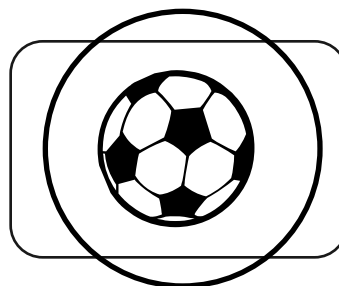
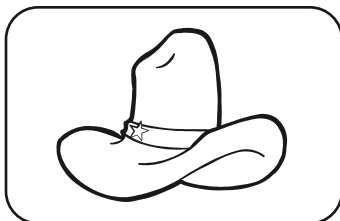
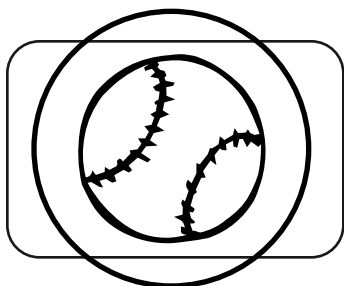

**Directions:** Draw a line to match the sentence with the picture.

I have a frog.

Nan is hot.

Bob had a plum.

The bus is big.

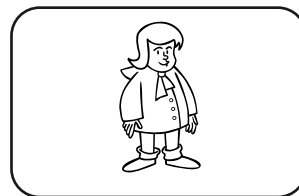
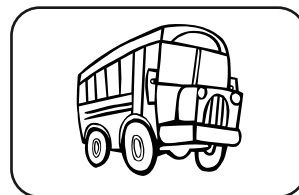
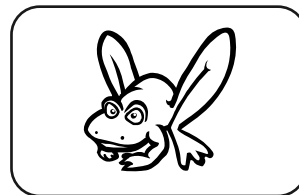
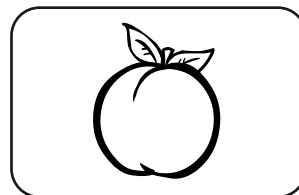





## Reading Words with Beginning Consonant Digraphs

**Directions:** Color the pictures that have the same beginning sound as **sheep**.

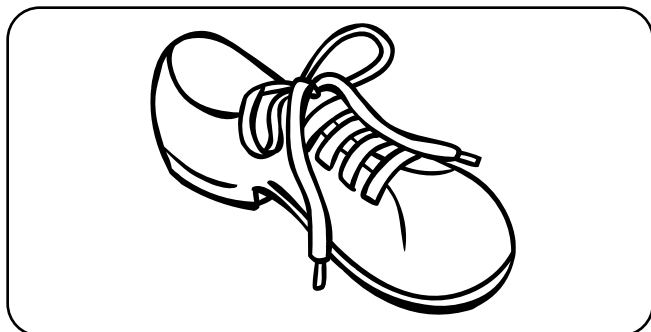
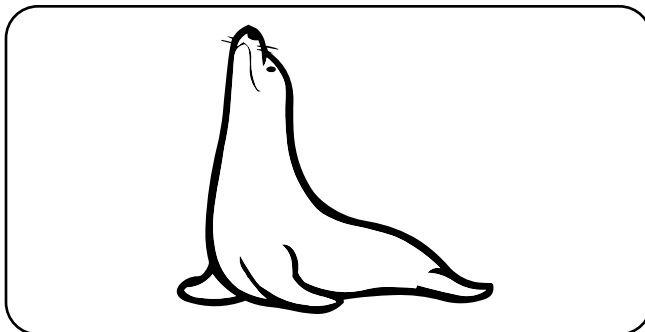
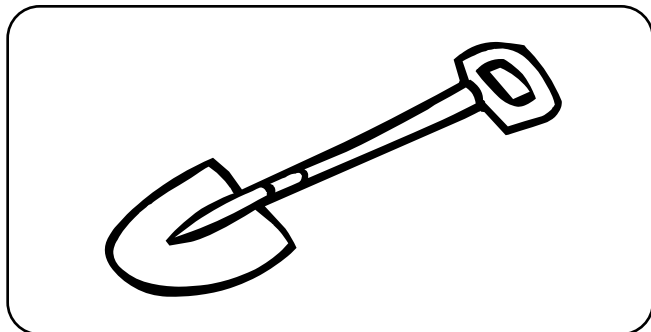
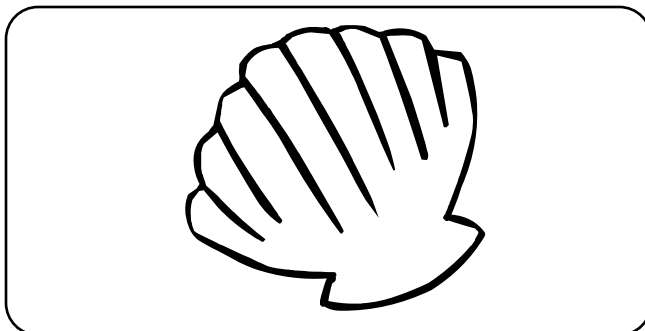
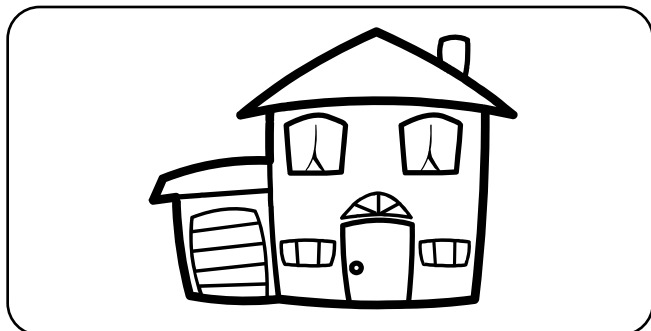
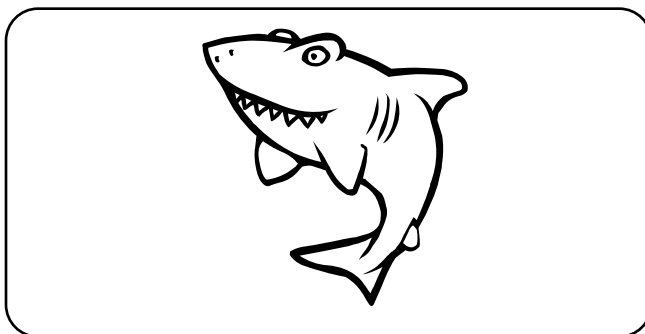
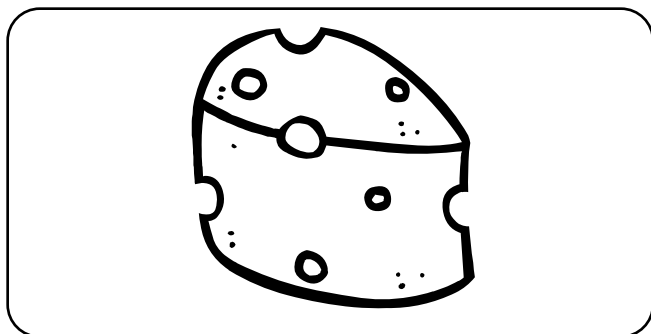

**Directions:** Read the words. For each row, color the picture that matches the word.

ship

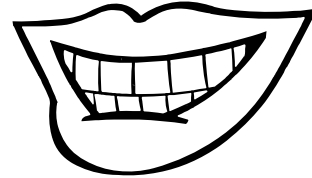
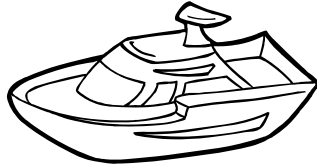

shell

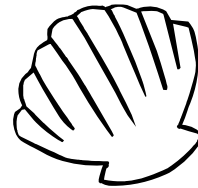

shed

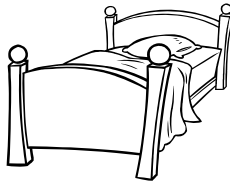

shop

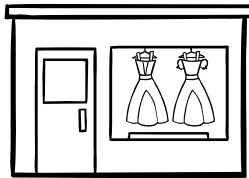



## Reading Words with Beginning Consonant Digraphs

**Directions:** Color the pictures that have the same beginning sound as **sheep**.

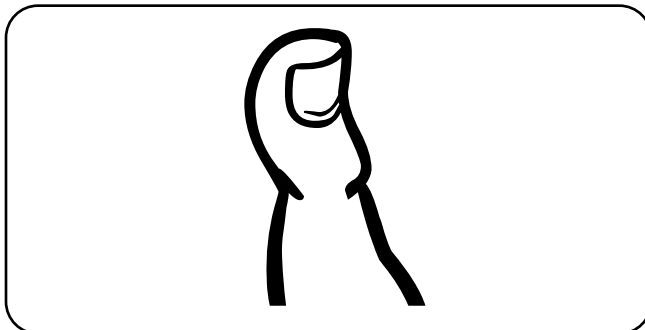
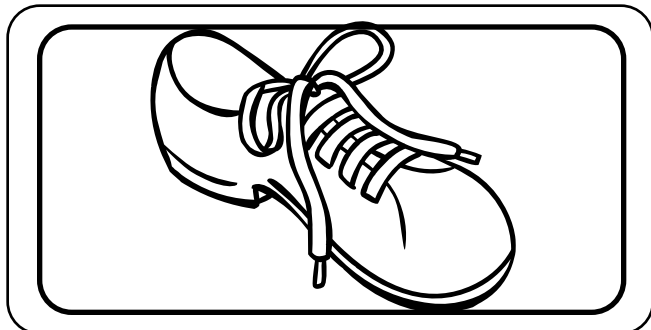
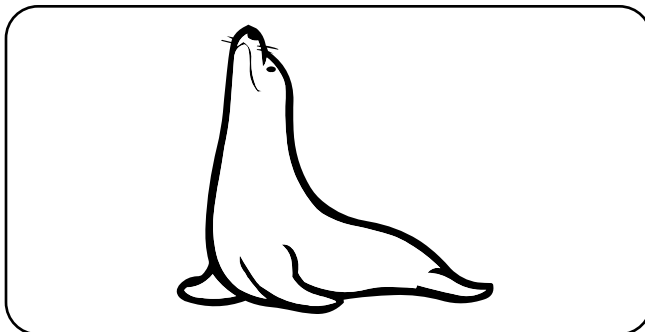
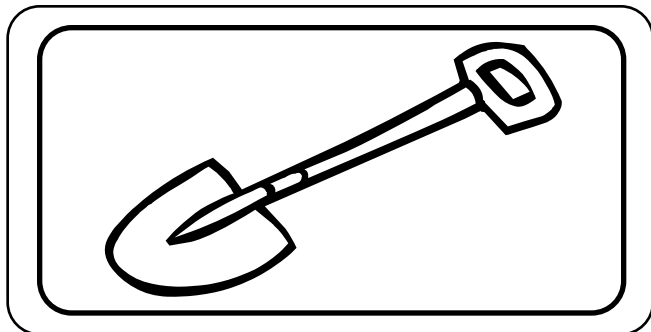
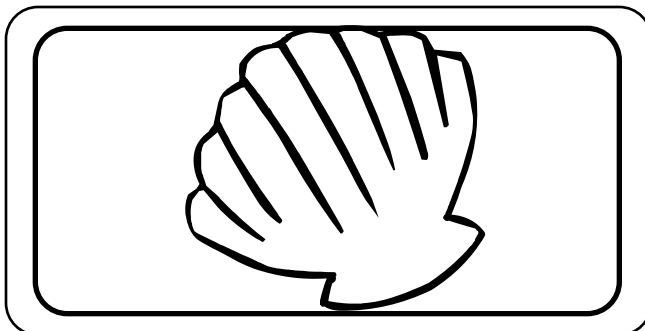
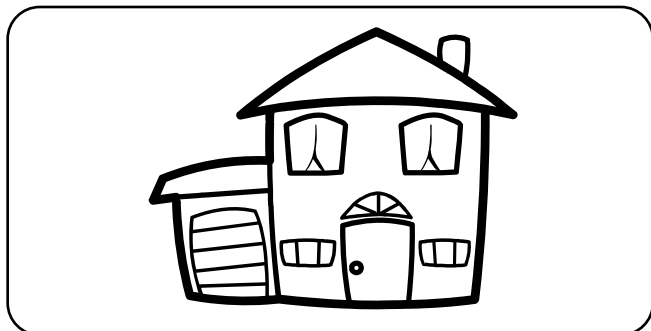
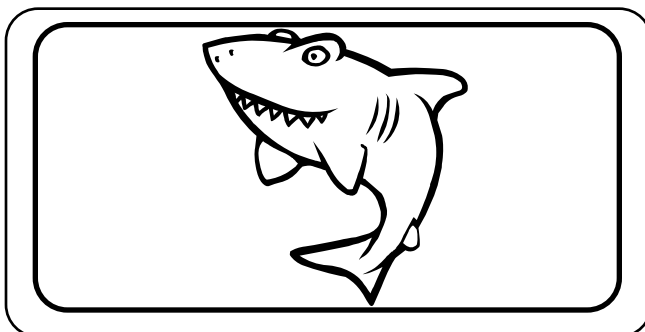
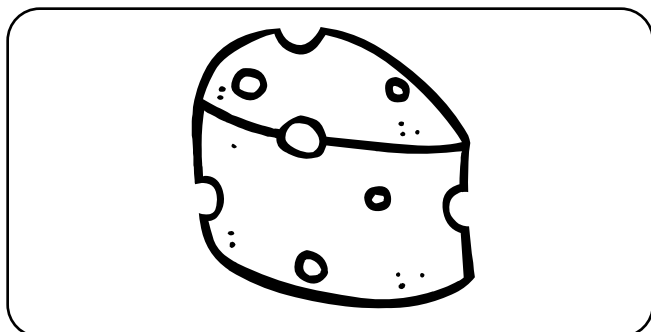

**Directions:** Read the words. For each row, color the picture that matches the word.

ship

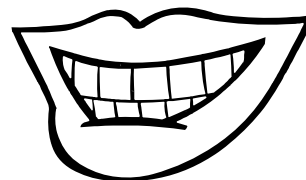
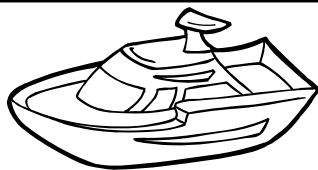

shell

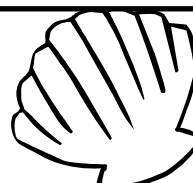
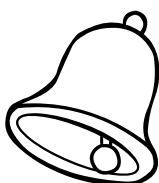

shed

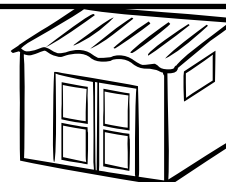
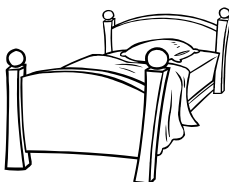

shop

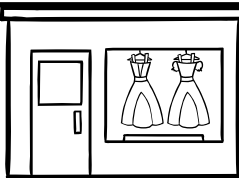

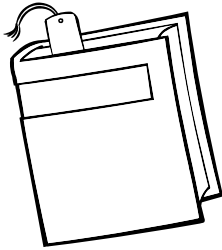

## Reading High Frequency Words

**Directions:** Cut out the pages. Put them in order. Staple the pages together. Then read the story. Circle the words **from** and **one**.

### Max's New Friend

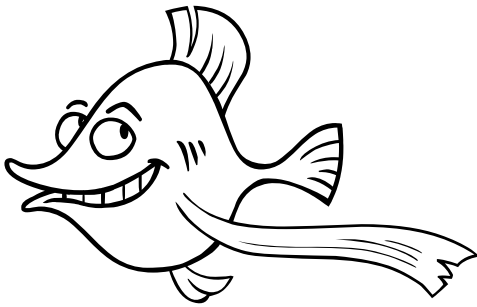

by Tricia Kauffman

Name \_\_\_\_\_

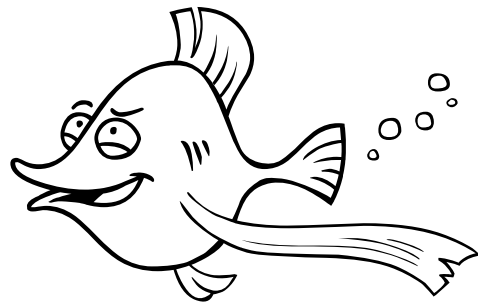

Max was a fish.  
He had one big fin. 1

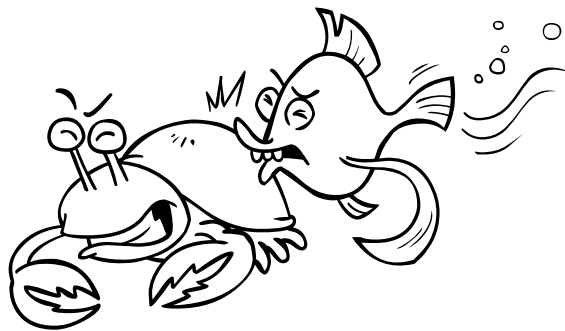

Max swam fast. Max  
swam in to one red crab. 2



The red crab was mad at  
Max. And Max felt sad. 3



He left the crab. He  
swam from the crab. 4

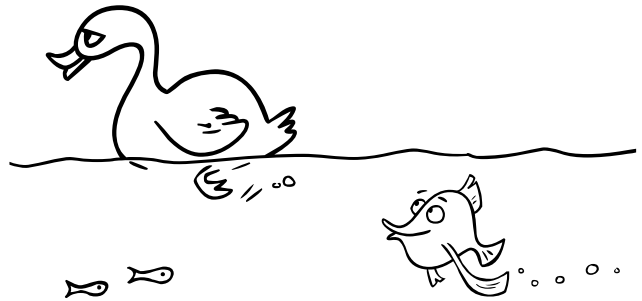

He swam to the top.  
Max swam into  
one yellow duck. 5

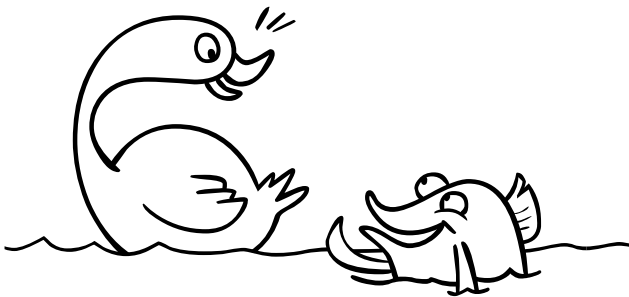

The yellow duck was glad  
to have met Max.  
And Max was glad. 6

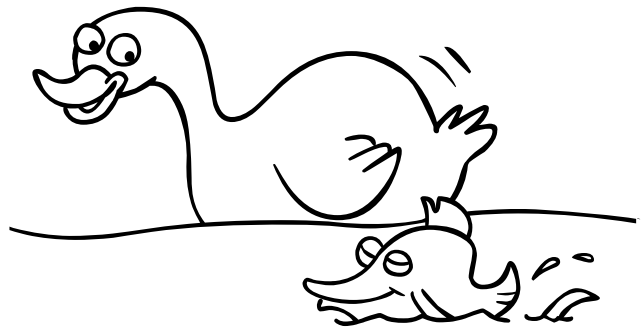

Max swam with the yellow  
duck. They swam and  
swam. They felt glad. 7

**Directions:** Draw pictures to answer the questions.

How did Max feel when he met the crab?

How did Max feel when he met the duck?

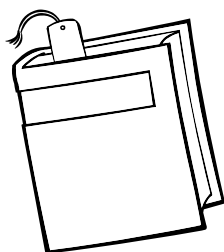

## Reading High Frequency Words

**Directions:** Cut out the pages. Put them in order. Staple the pages together. Then read the story. Circle the words from and one.

### Max's New Friend

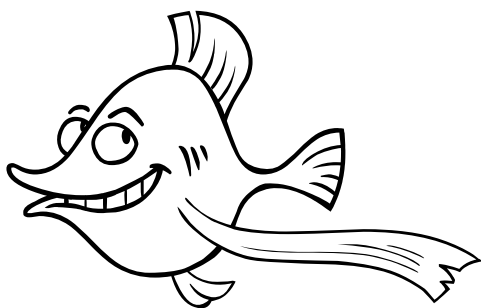

by Tricia Kauffman

Name \_\_\_\_\_

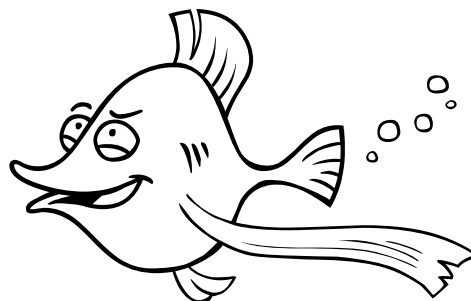

Max was a fish.  
He had one big fin. 1

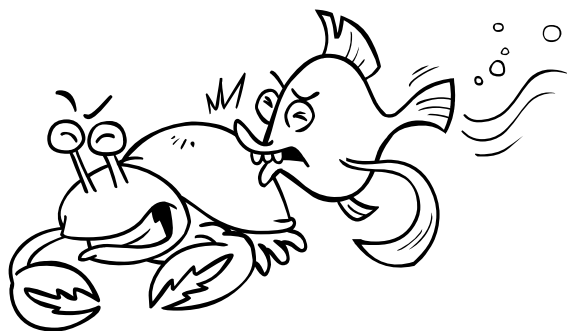

Max swam fast. Max  
swam in to one red crab. 2



The red crab was mad at  
Max. And Max felt sad. 3





He left the crab. He swam **from** the crab. 4

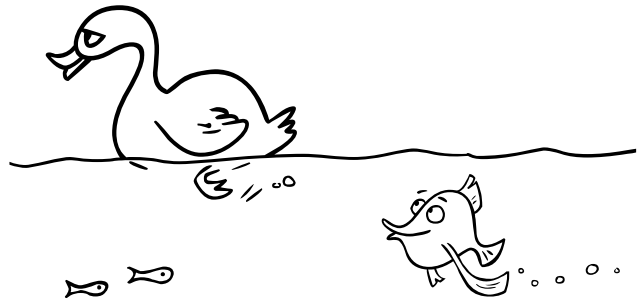

He swam to the top. Max swam into **one** yellow duck. 5

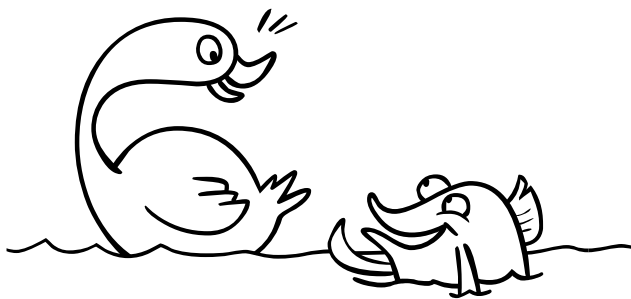

The yellow duck was glad to have met Max. And Max was glad. 6

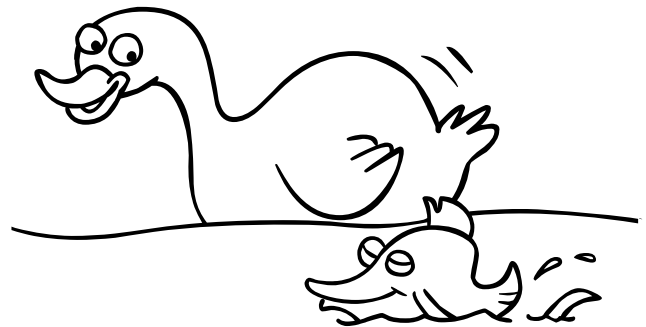

Max swam with the yellow duck. They swam and swam. They felt glad. 7

**Directions:** Draw pictures to answer the questions.

How did Max feel when he met the crab?

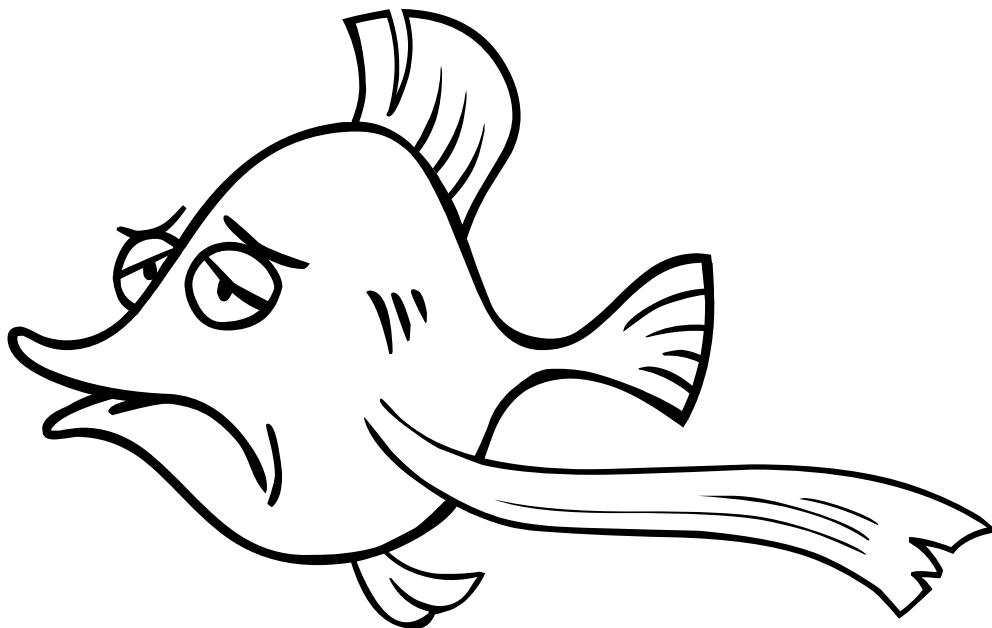

How did Max feel when he met the duck?

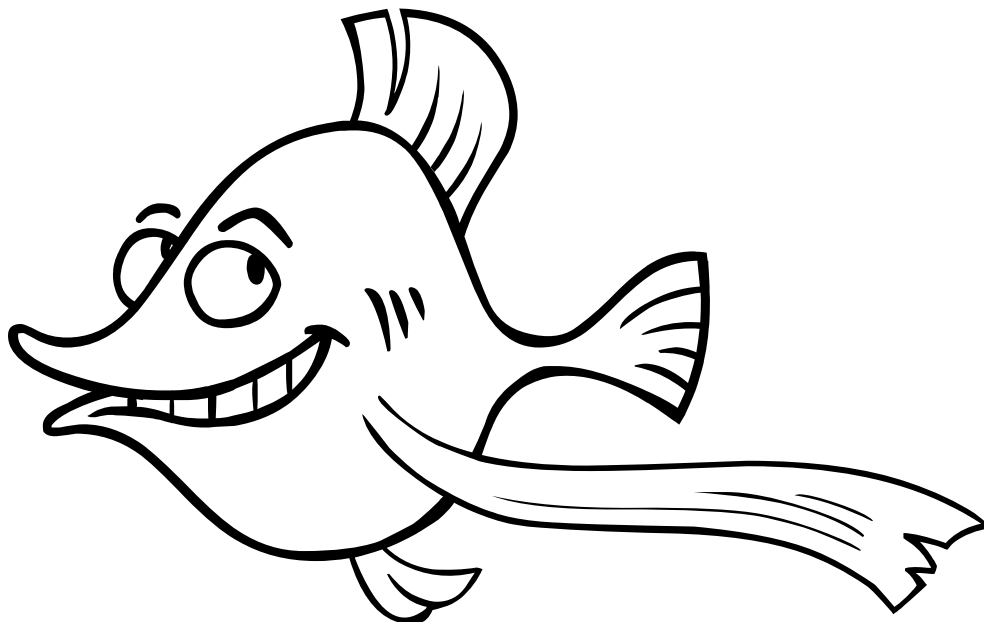

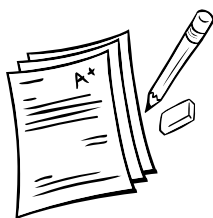

## Identifying the Correct Sequence of Events

**Directions:** Cut out the pictures. Then paste them in the boxes in the correct order.

1.

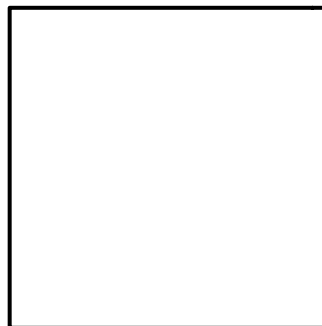
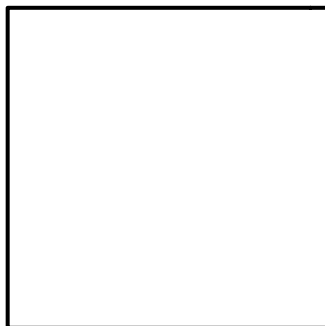
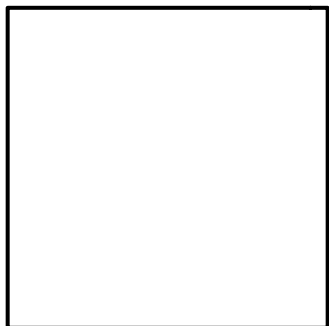

2.

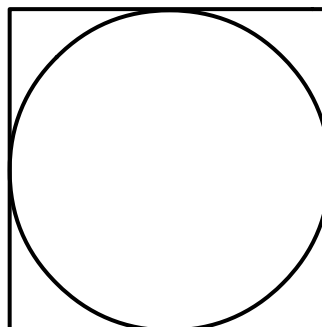
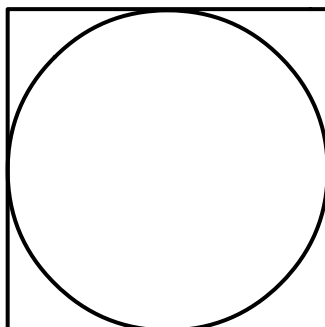
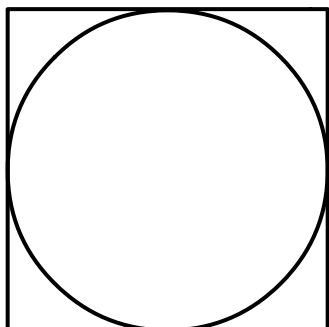

3.

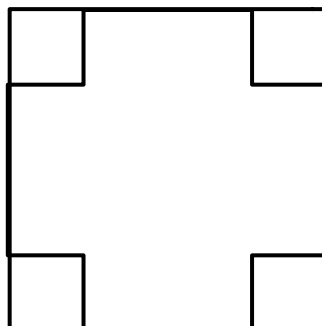
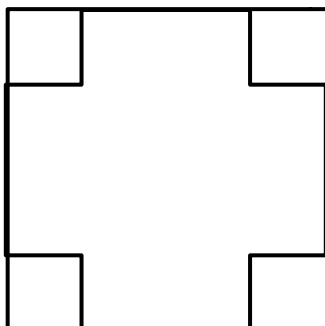
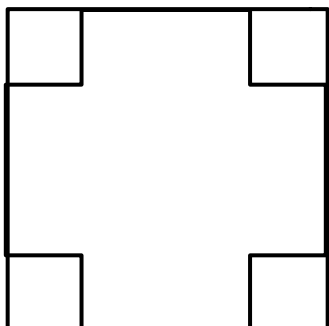

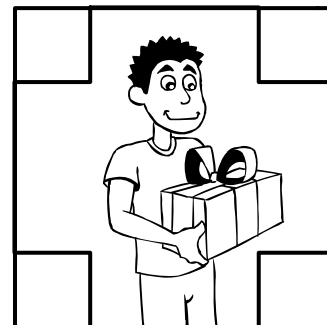
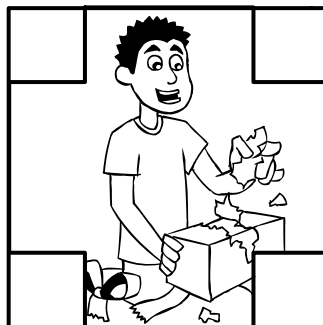
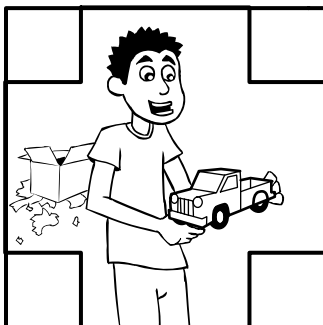
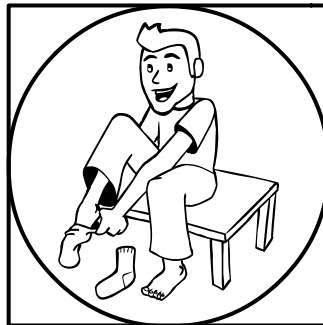
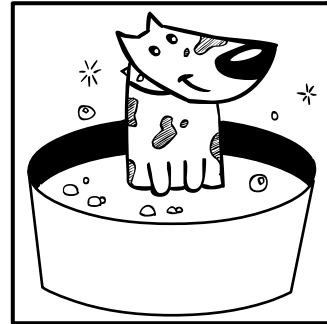
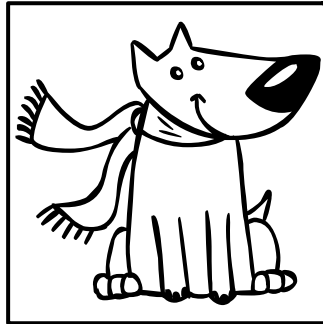
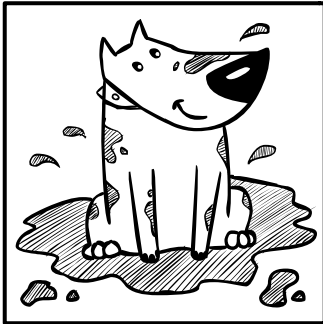



## Identifying the Correct Sequence of Events

**Directions:** Cut out the pictures. Then paste them in the boxes in the correct order.

1.

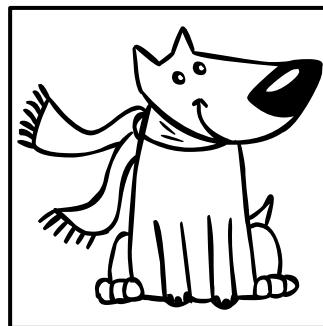
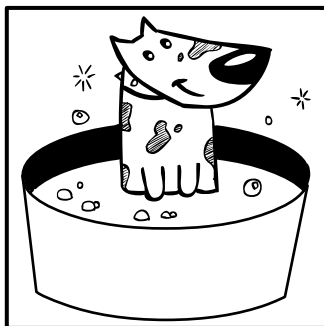
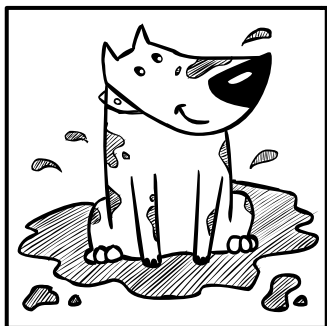

2.



3.

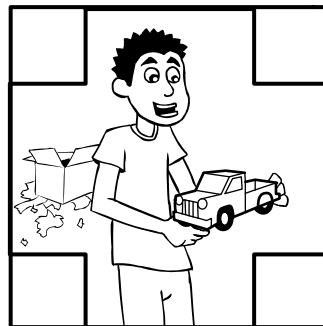
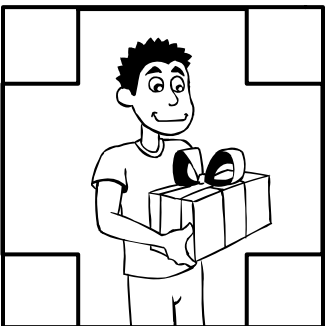

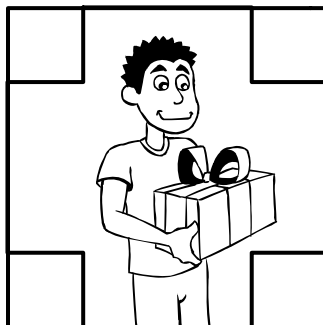
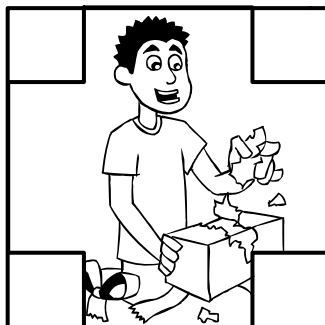
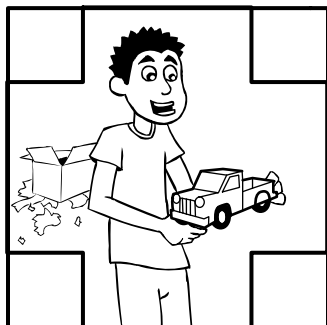
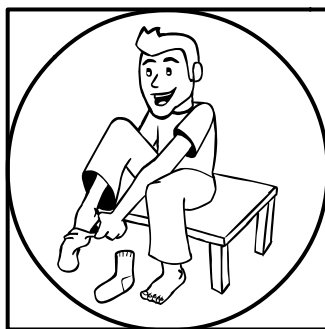
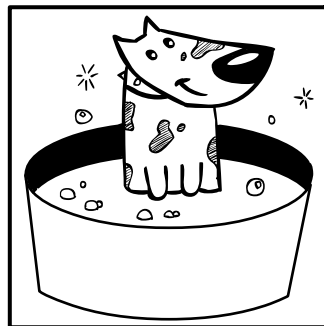
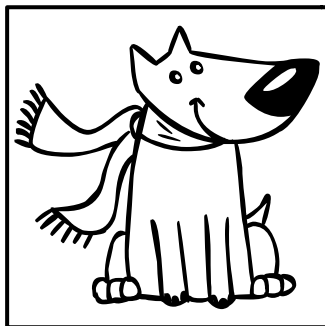
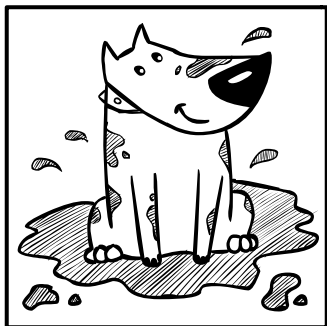



## Identifying Cause and Effect

**Directions:** Draw a line to match the pictures on the left to the pictures on the right.

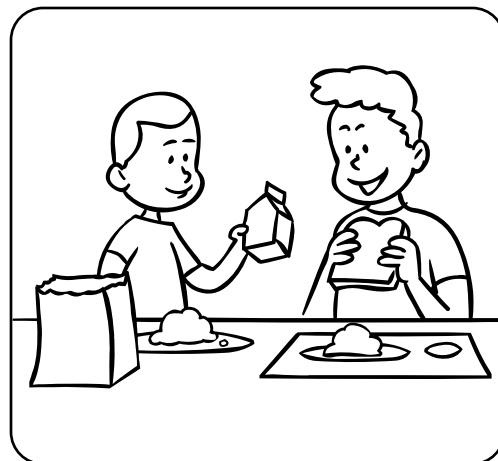
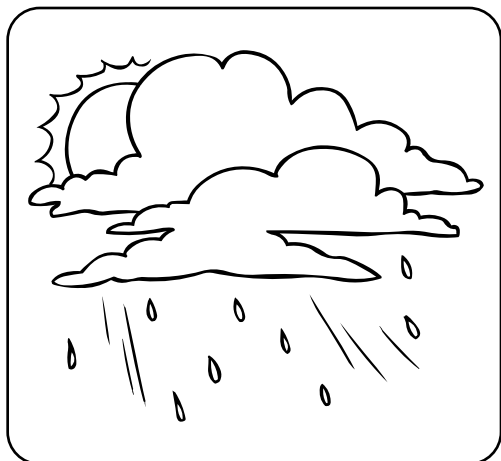
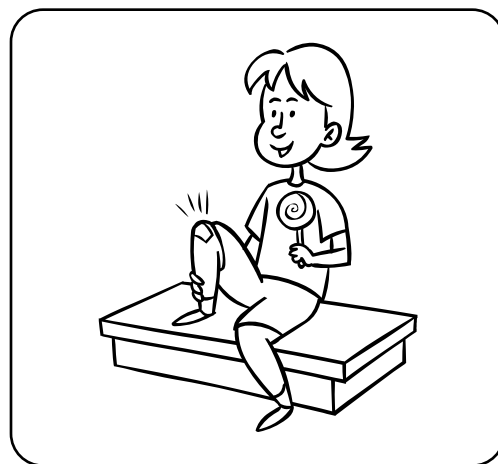
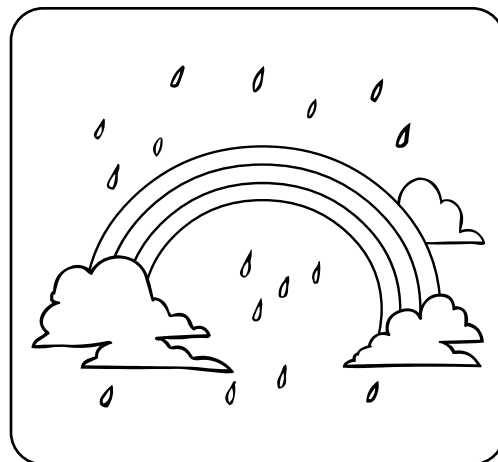
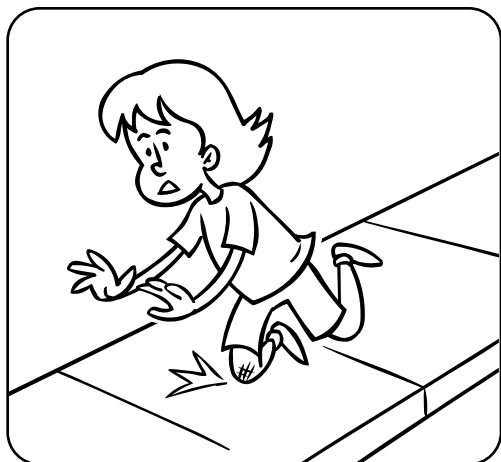



## Identifying Cause and Effect

**Directions:** Draw a line to match the pictures on the left to the pictures on the right.

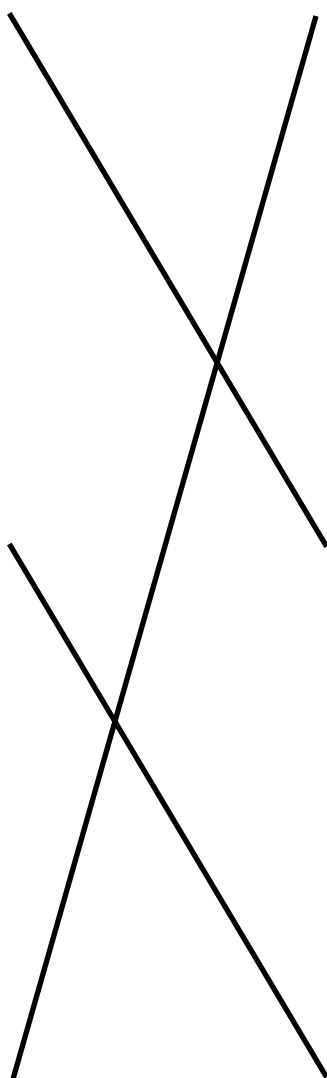
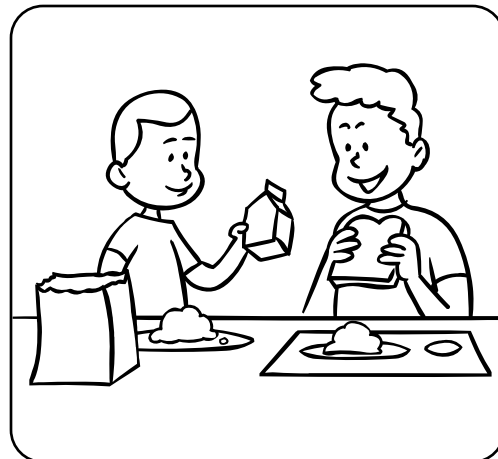
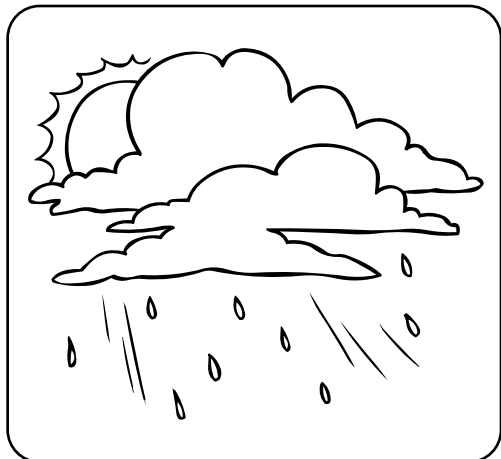
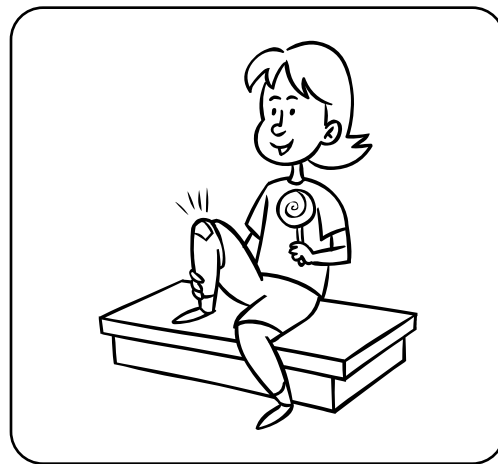
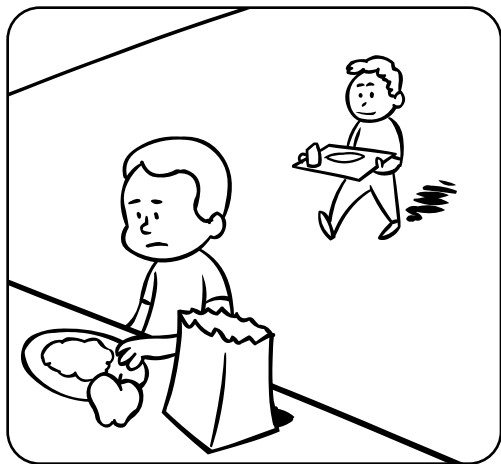
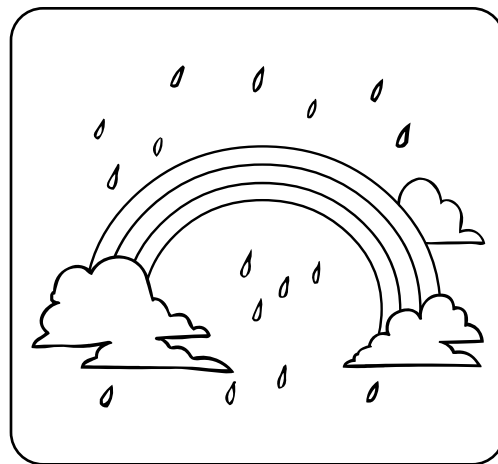
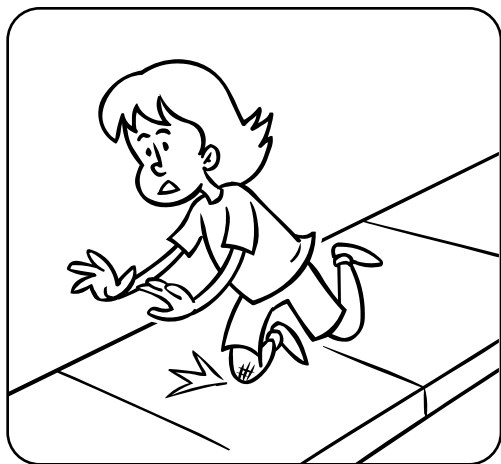



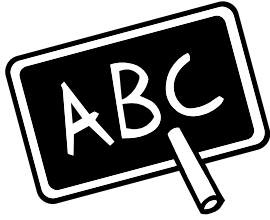

## Blending CVCC and CCVC Words

**Directions:** Read each sentence. Then cut out the pictures. Paste each picture below the sentence it matches.

1. The jet was a gift from Ted.

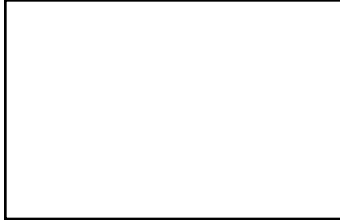

4. I have a new jug for a bug.

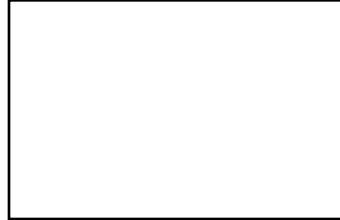

2. They want to shop for a doll.



5. We are as tall as the mops.

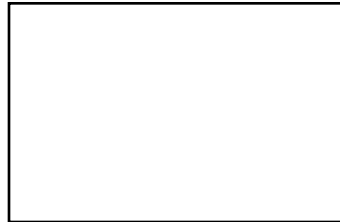

3. He will jump on that mat.

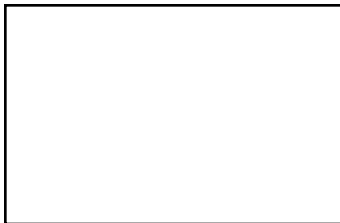

6. You can have the cap.

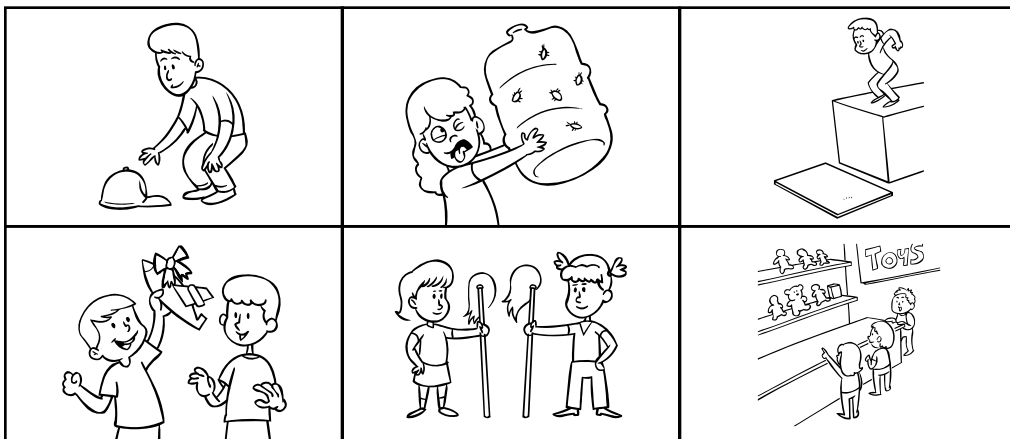
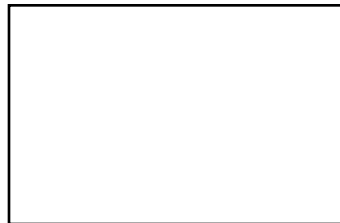

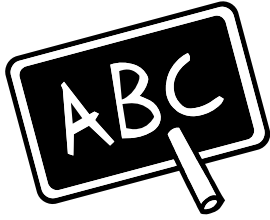

## Blending CVCC and CCVC Words

**Directions:** Read each sentence. Then cut out the pictures. Paste each picture below the sentence it matches.

1. The jet was a gift from Ted.

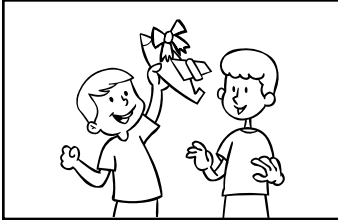

4. I have a new jug for a bug.



2. They want to shop for a doll.

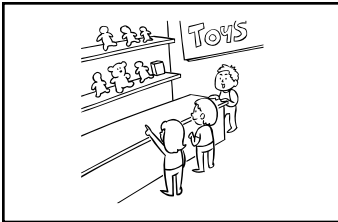

5. We are as tall as the mops.

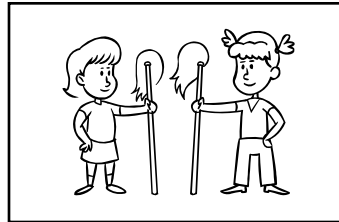

3. He will jump on that mat.

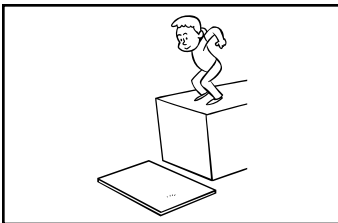

6. You can have the cap.

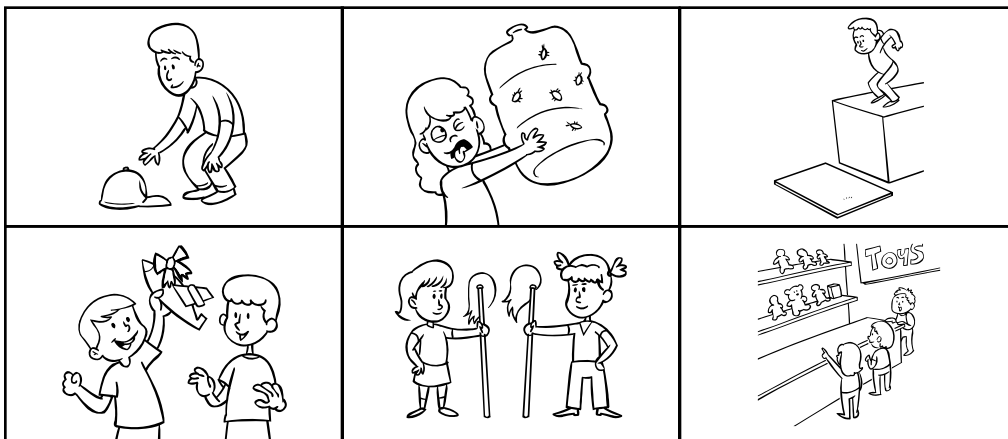
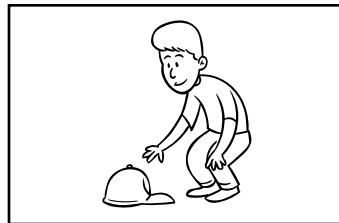

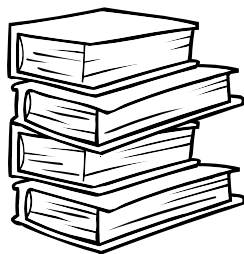

## Identifying Sequence of Events and Blending Words

**Directions:** Read the story. Cut out the pictures. Paste the pictures in the correct order. Then draw a picture to answer the question.

Ben will get pants for his job.

This shop has pants.

First, he sees pants with spots.

They are not for his job.

Next, he sees pants and a cap.

They are not for his job.

Last, he sees pants and a vest.

He will pick the pants and a vest!

**First**

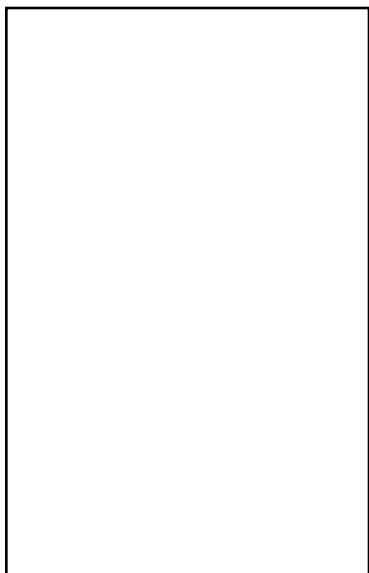

**Next**

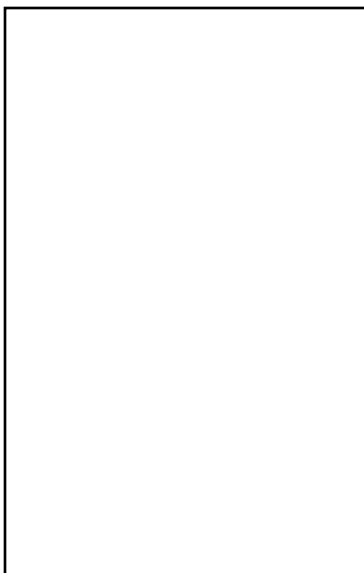

**Last**



What could Ben's job be?

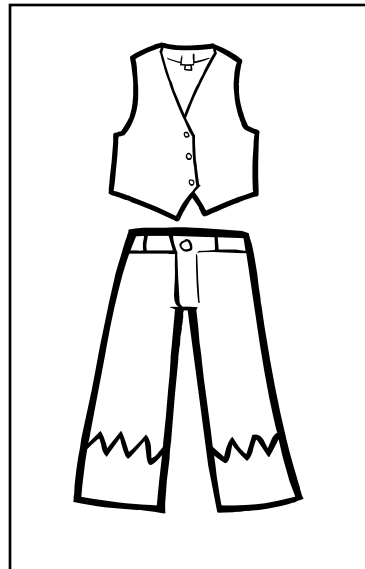
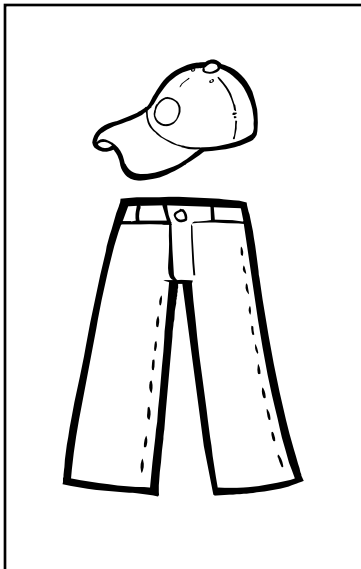
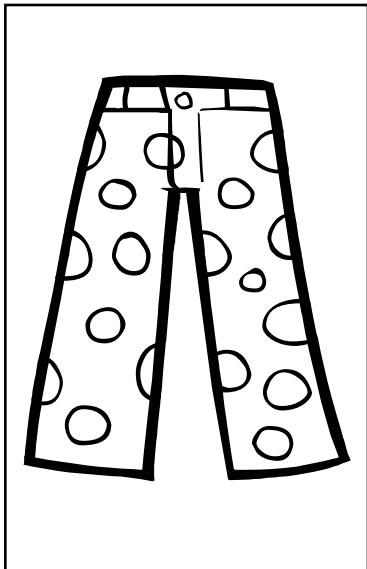

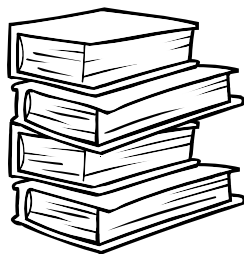

## Identifying Sequence of Events and Blending Words

**Directions:** Read the story. Cut out the pictures. Paste the pictures in the correct order. Then draw a picture to answer the question.

Ben will get pants for his job.

This shop has pants.

First, he sees pants with spots.

They are not for his job.

Next, he sees pants and a cap.

They are not for his job.

Last, he sees pants and a vest.

He will pick the pants and a vest!

**First**

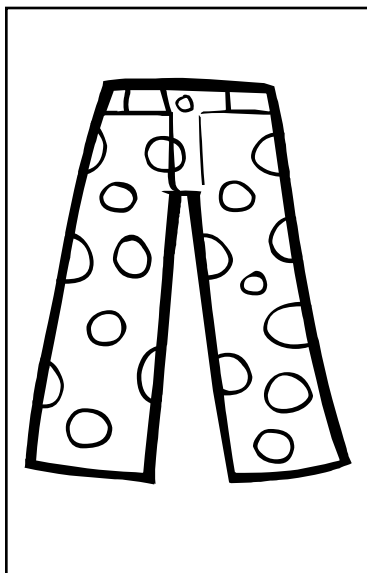

**Next**

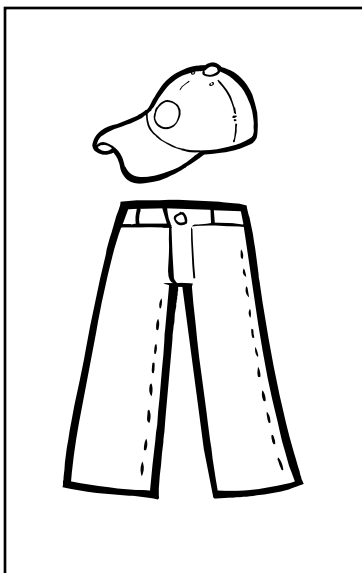

**Last**

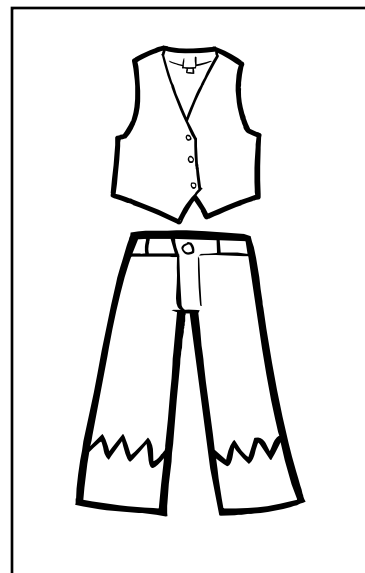

What could Ben's job be?

**Answers will vary.**

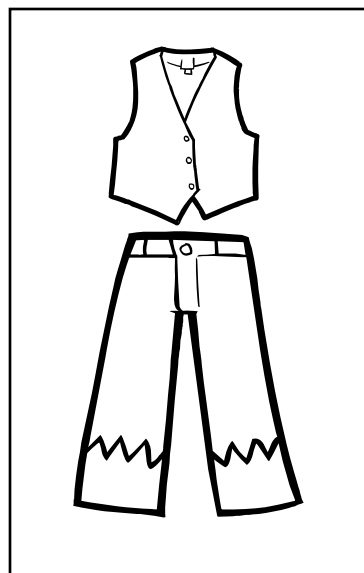
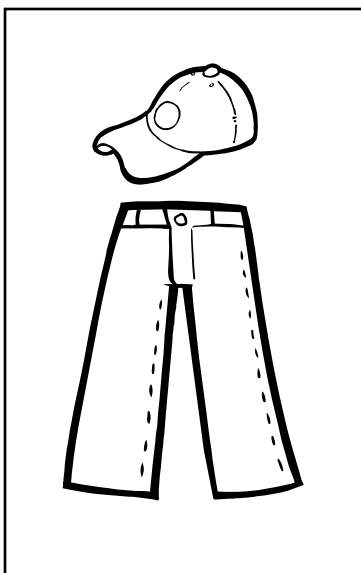
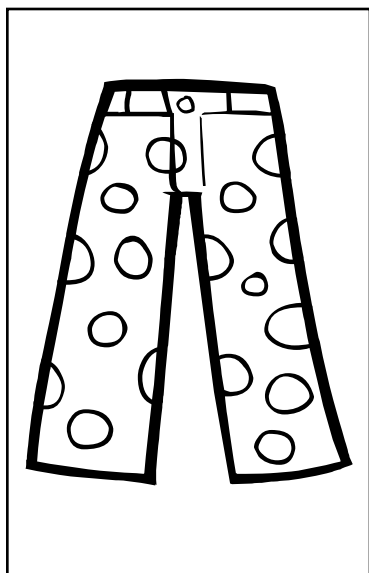

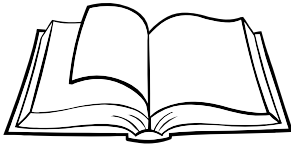

## Reading Consonant Digraphs

**Directions:** For each row, color the picture that has the same beginning sound as the word in the box.

three 3

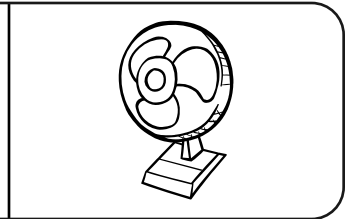
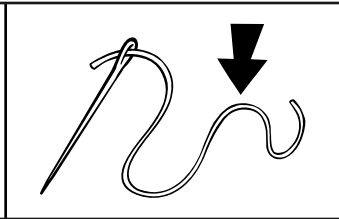
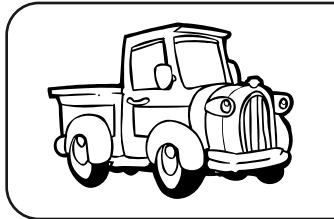

thin

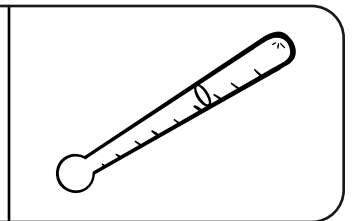
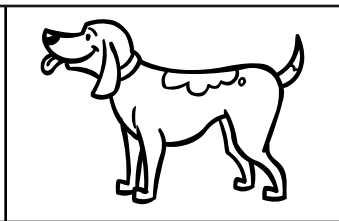
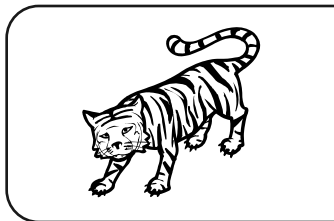

thumb

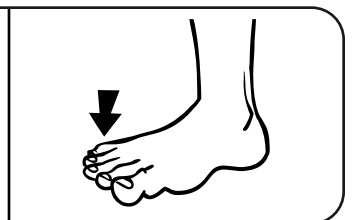
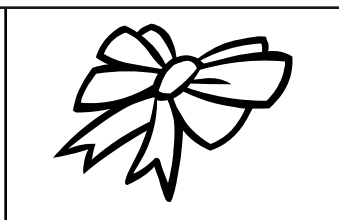
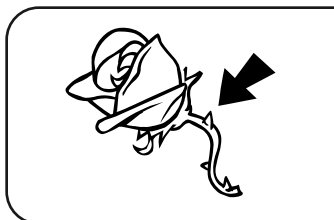

**Directions:** Read the story. Circle the letter that completes each word. Then write the letter on the line.

“What is that?”  
said Cat.

h b r

“That is a \_\_\_\_\_at,”  
said Nat.

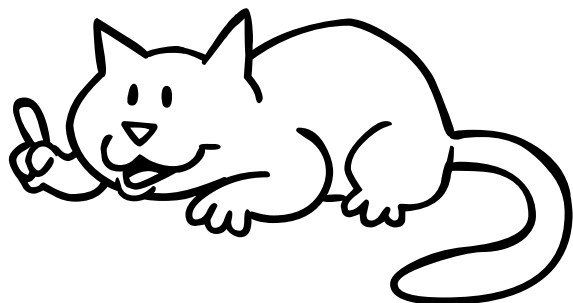

“What is that?”  
said Cat.

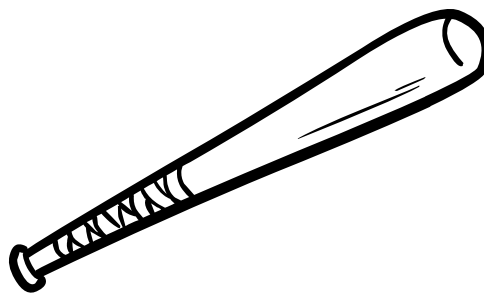

h b r

“That is a \_\_\_\_\_at,”  
said Nat.

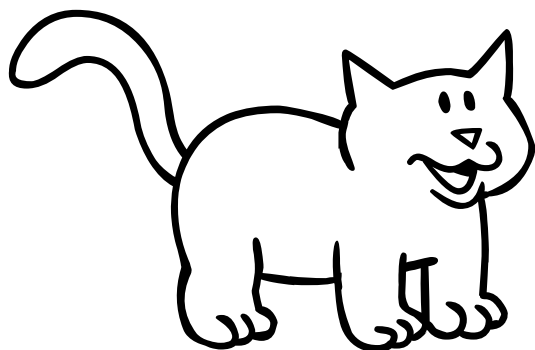

“What is that?”  
said Cat.

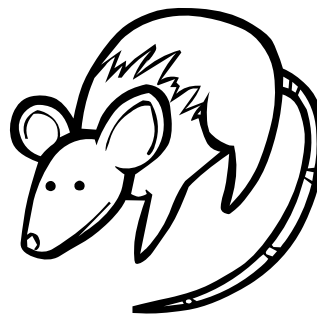

h b r

“That is a \_\_\_\_\_at,”  
said Nat.



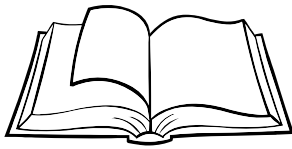

## Reading Consonant Digraphs

**Directions:** For each row, color the picture that has the same beginning sound as the word in the box.

three 3

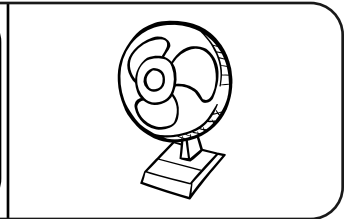
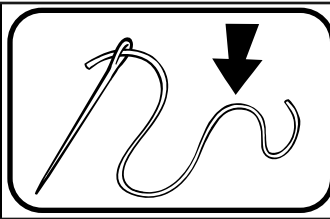
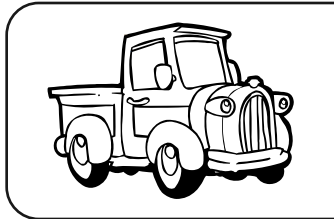

thin

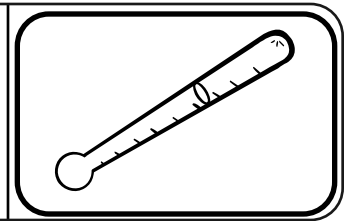
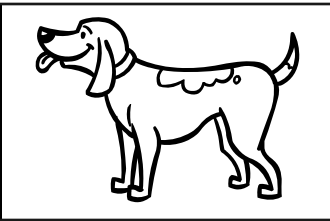
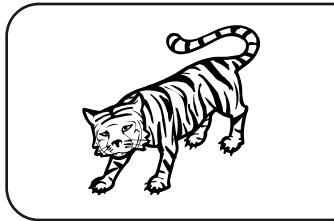

thumb

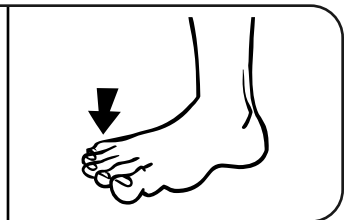
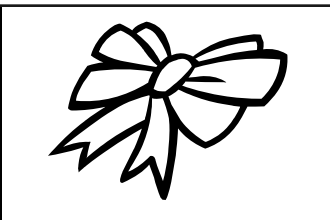
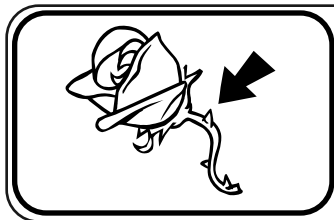

**Directions:** Read the story. Circle the letter that completes each word. Then write the letter on the line.

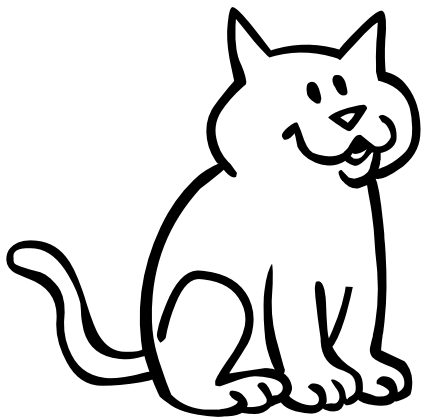

“What is that?”  
said Cat.

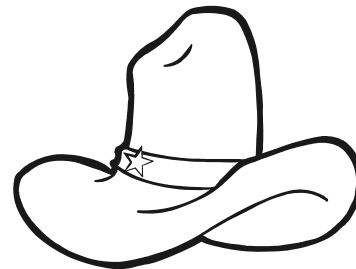

(h) b r

“That is a h at,”  
said Nat.

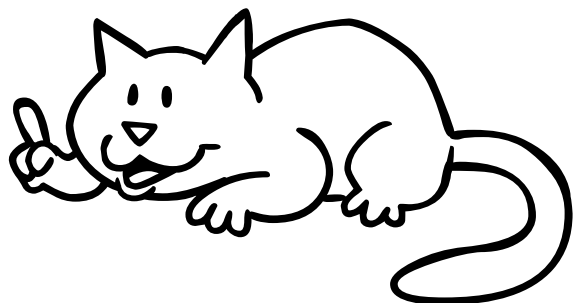

“What is that?”  
said Cat.

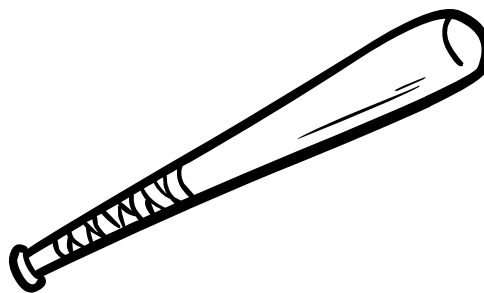

h **b** r

“That is a   b  at,”  
said Nat.

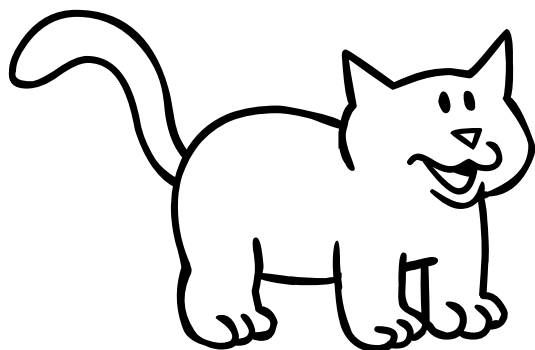

“What is that?”  
said Cat.

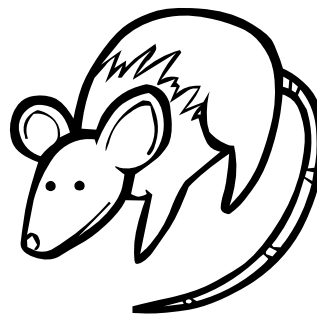

h b **r**

“That is a   r  at,”  
said Nat.



## Reading High Frequency Words

**Directions:** Read the story. Then answer the questions.



Sid was a kid.  
He had a jar with a lid.

1

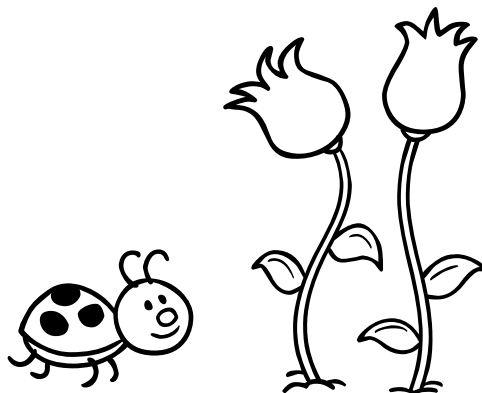

Sid sat by the flowers.  
He saw a bug. He  
said, "I want to look  
at the bug."

2



He put the bug in the  
jar. He put on the lid.

3



Sid sat on a rug to  
look at the bug. But  
the bug was sad.

4



Sid had a plan. Sid said, "I will let the bug go!" The bug ran by the rug. 5



Sid was happy, but he missed the bug. 6

Draw a picture that shows where Sid sat.

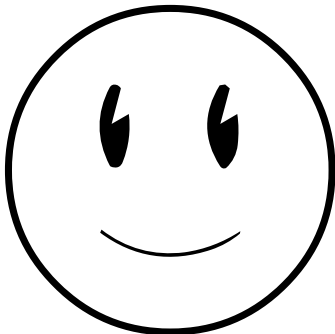

Color the face that shows how the bug felt being in the jar.



## Reading High Frequency Words

**Directions:** Read the story. Then answer the questions.



Sid was a kid.  
He had a jar with a lid.

1

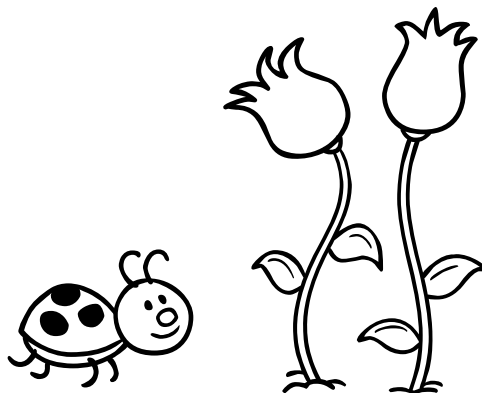

Sid sat by the flowers.  
He saw a bug. He  
said, "I want to look  
at the bug."

2



He put the bug in the  
jar. He put on the lid.

3



Sid sat on a rug to  
look at the bug. But  
the bug was sad.

4



Sid had a plan. Sid said, "I will let the bug go!" The bug ran by the rug. 5



Sid was happy, but he missed the bug. 6

Draw a picture that shows where Sid sat.

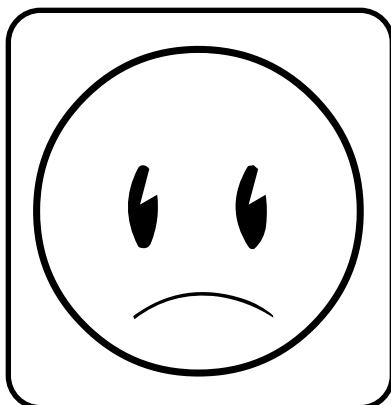
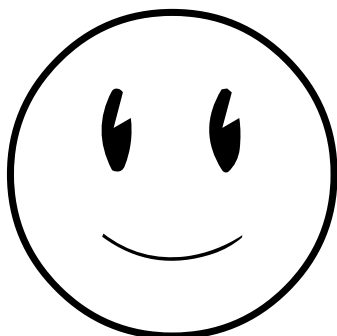
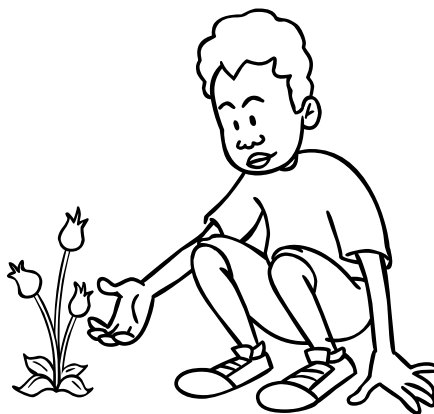

Color the face that shows how the bug felt being in the jar.

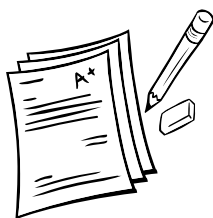

## Identifying the Correct Sequence of Events

**Directions:** Cut out the pictures. Then paste them in the boxes in the correct order.

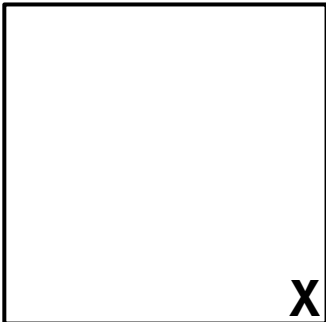
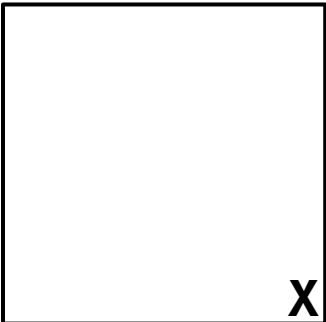
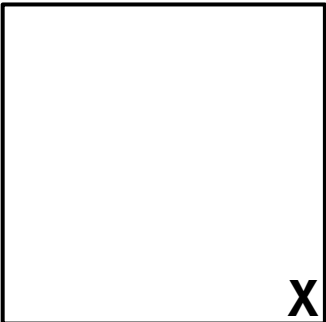
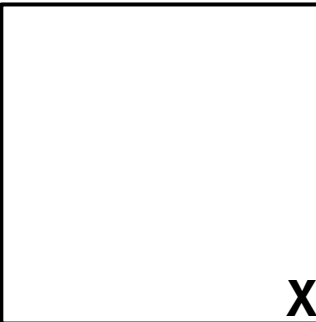
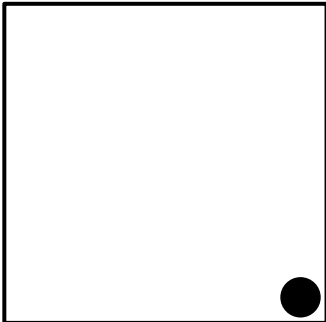
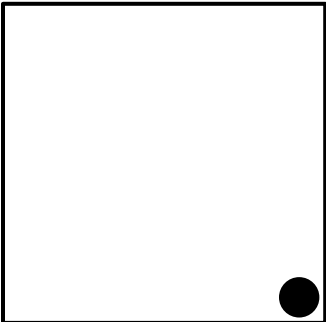
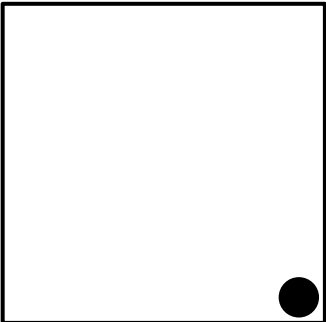
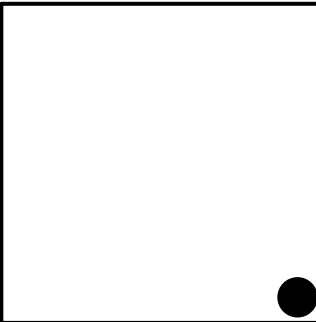
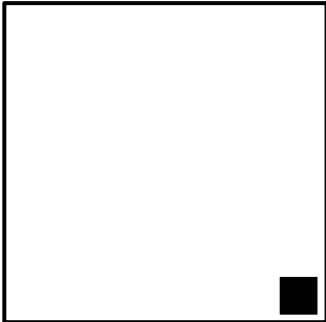
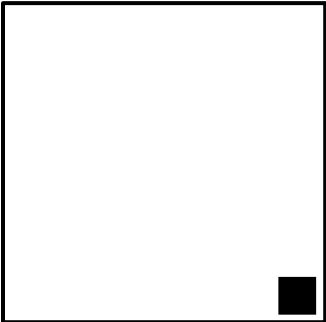
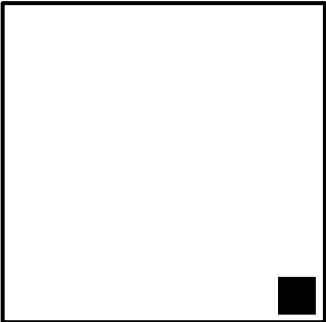
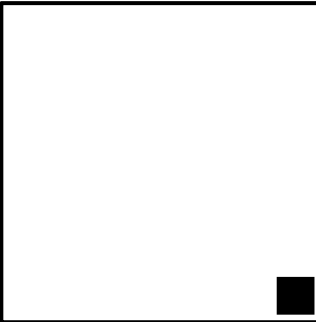
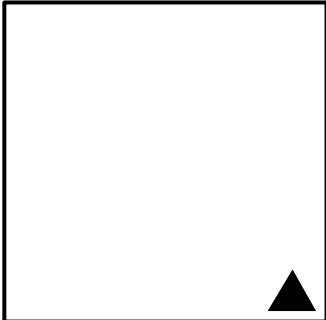
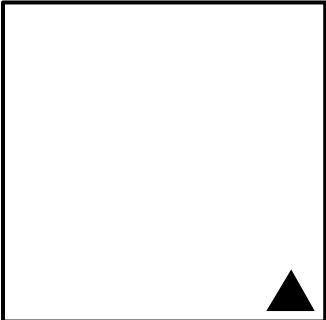
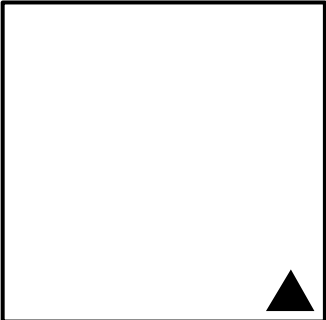
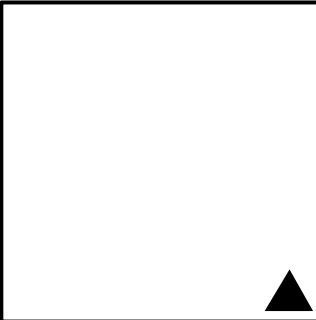

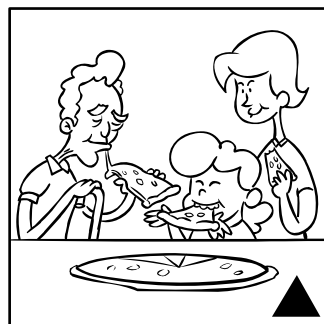
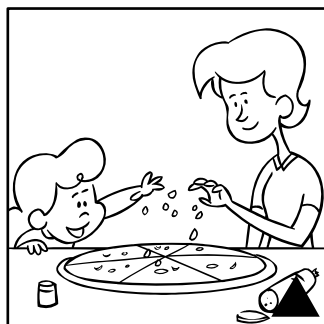
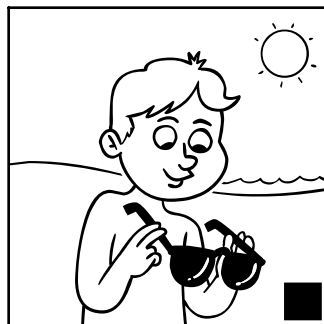
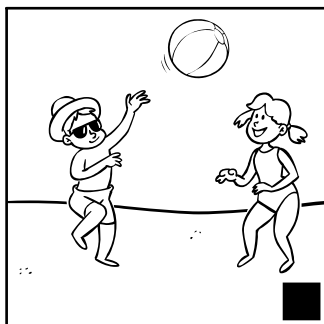
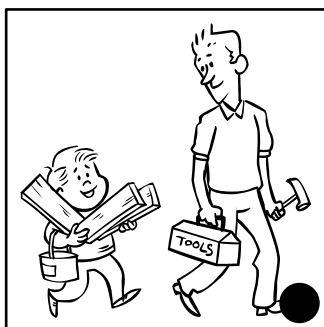
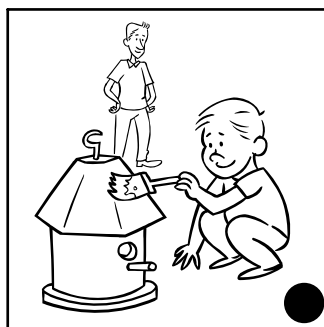
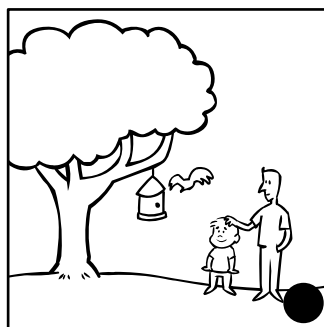
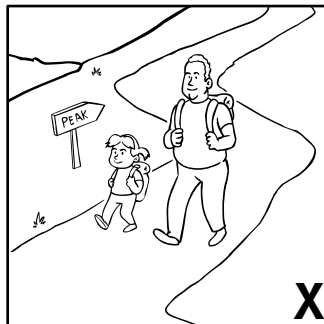
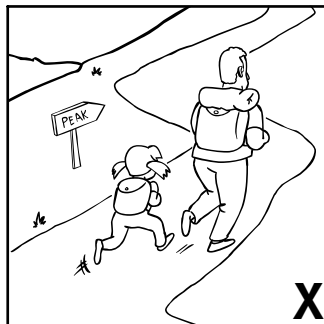
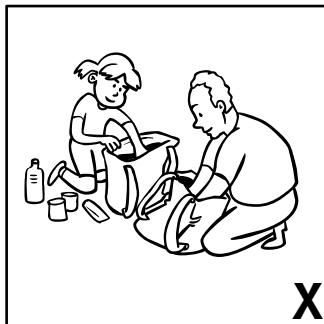
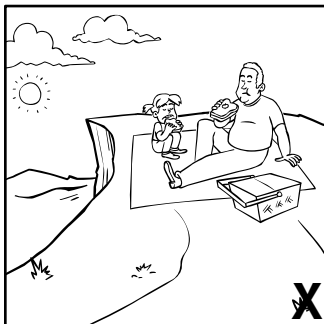



## Identifying the Correct Sequence of Events

**Directions:** Cut out the pictures. Then paste them in the boxes in the correct order.

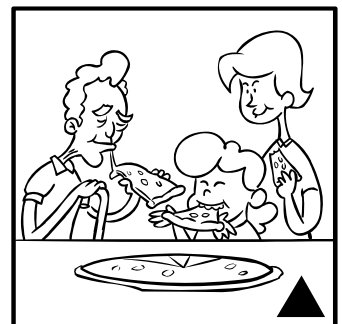
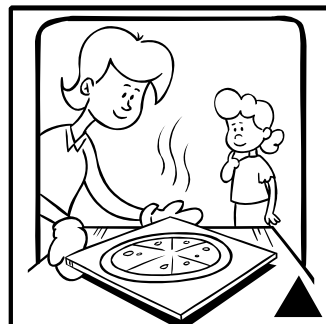
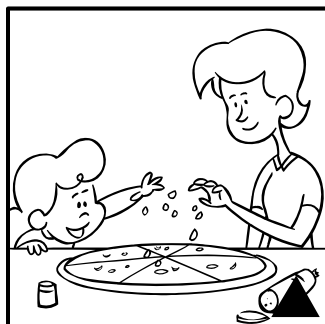
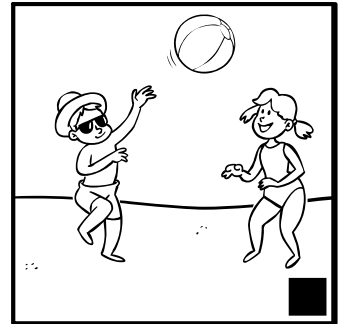
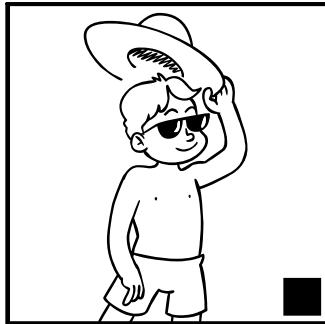
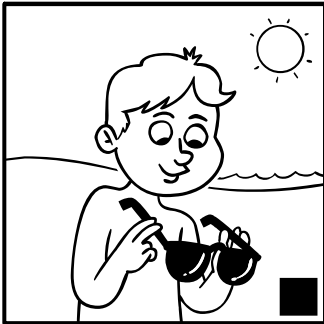
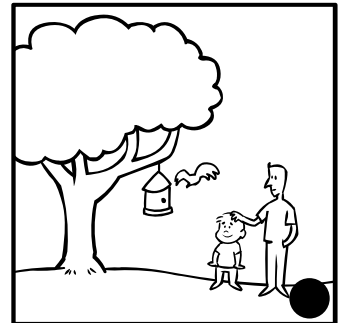
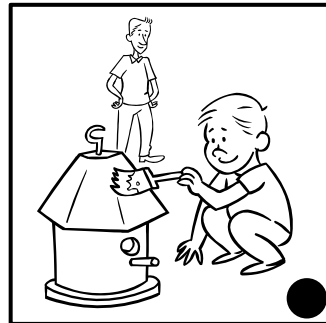
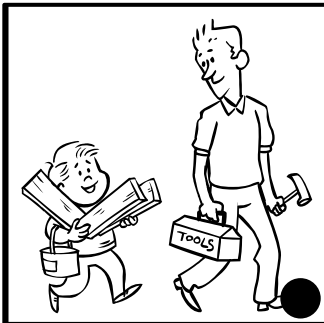
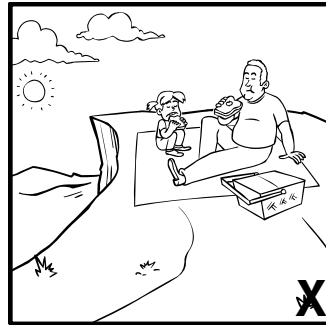
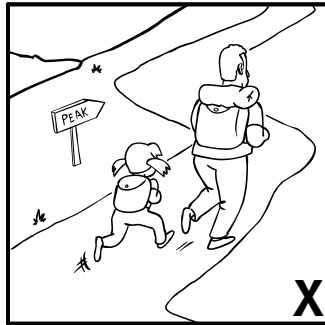

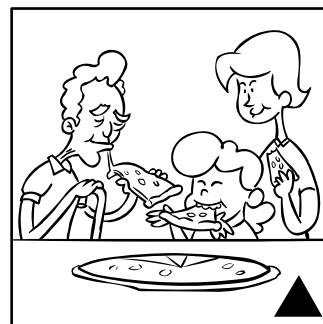
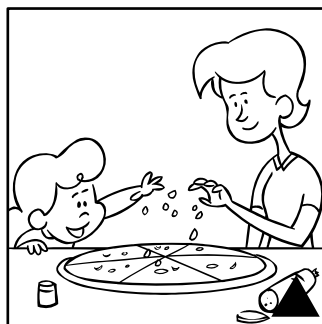
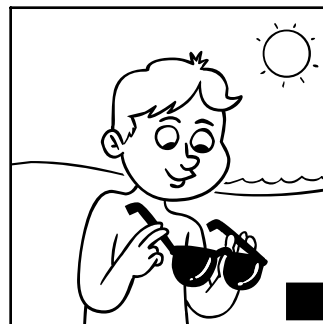
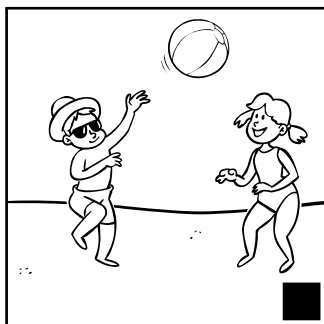
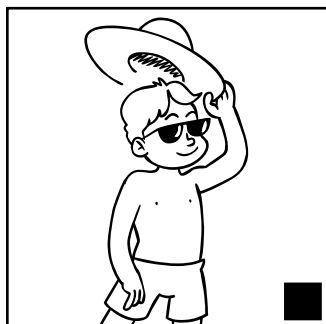
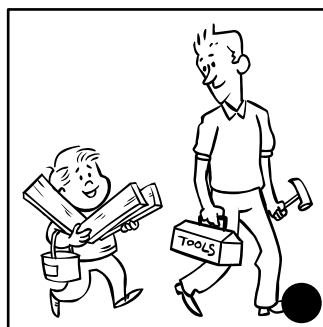
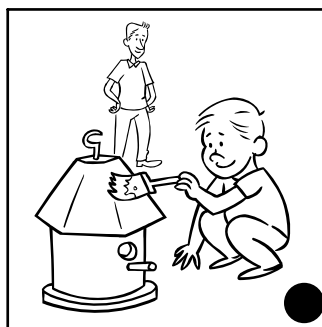
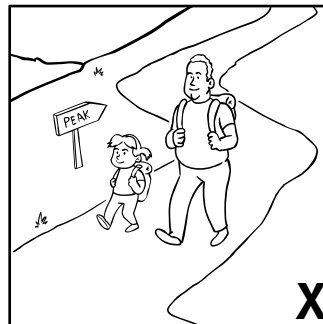
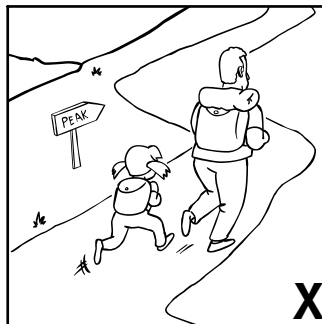
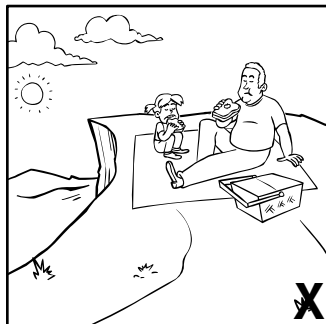



## Comparing and Contrasting

**Directions:** Look at each picture. Read the words. Then tell how the dogs are alike and different.

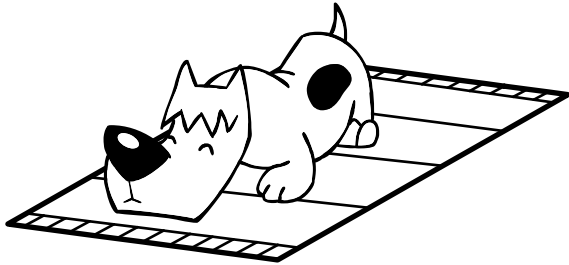

This is Ned. He is a dog. Ned likes to sleep. He sleeps on a mat.

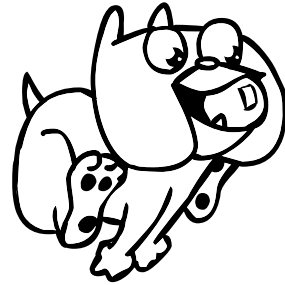

This is Jed. He likes to run. He runs with his ball.

How are Ned and Jed the same? Draw a picture of how they are the same.

How are Ned and Jed different? Draw a picture of how they are different.



## Comparing and Contrasting

**Directions:** Look at each picture. Read the words. Then tell how the dogs are alike and different.

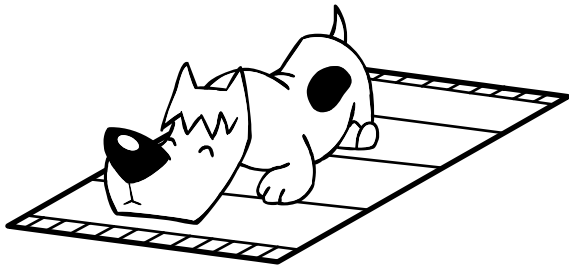

This is Ned. He is a dog. Ned likes to sleep. He sleeps on a mat.

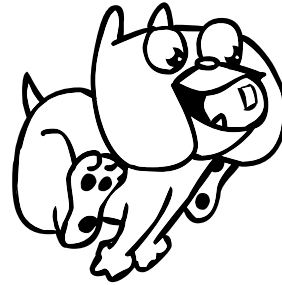

This is Jed. He likes to run. He runs with his ball.

How are Ned and Jed the same? Draw a picture of how they are the same.

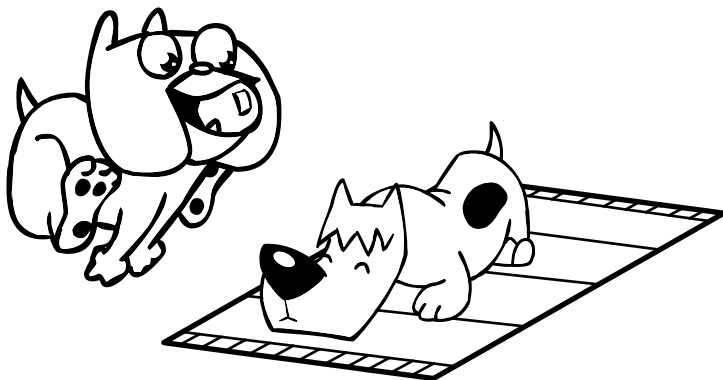
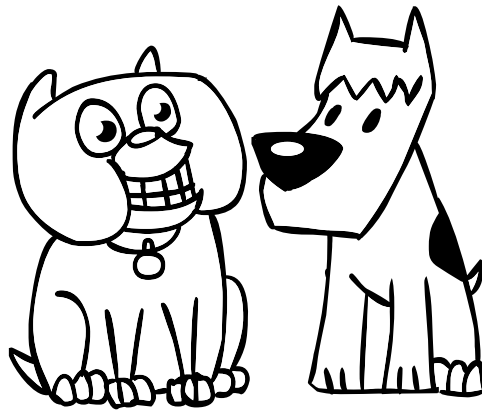

How are Ned and Jed different? Draw a picture of how they are different.

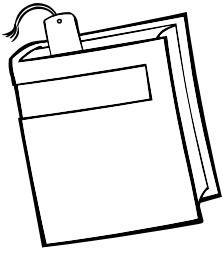

## Reading High Frequency Words and Comparing and Contrasting

**Directions:** Read the story. Then draw pictures to answer the questions.

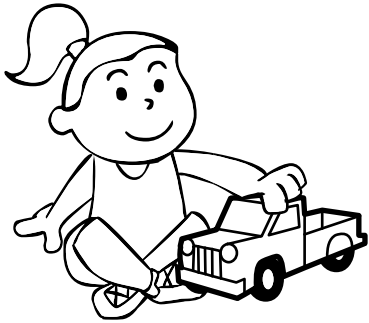

Kim had a toy truck.  
She played by the toy  
chest. That was fun.



Tim had a toy jet. He  
played by the steps.  
That was fun.

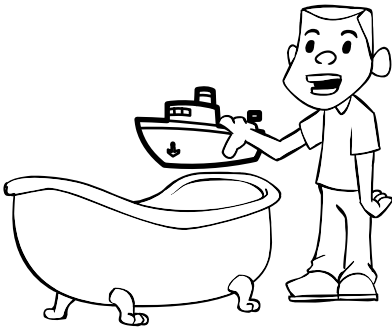

Jim had a ship. He  
played by the tub.  
That was fun.

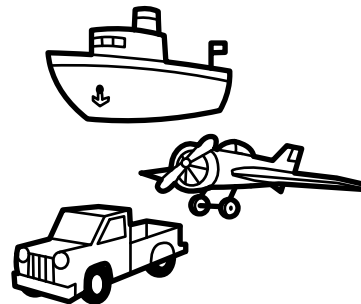

Kim and Tim and Jim  
all had fun. Now they  
can have fun together!

What is this story about?

How are Kim, Tim, and Jim alike?

How are Kim, Tim, and Jim different?

Draw the toy you like most.

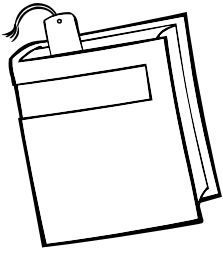

## Reading High Frequency Words and Comparing and Contrasting

**Directions:** Read the story. Then draw pictures to answer the questions.

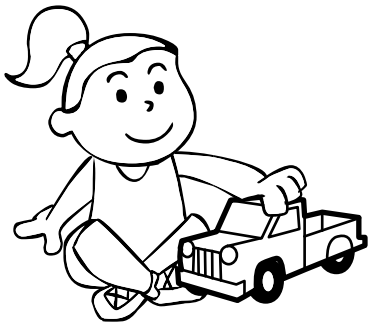

Kim had a toy truck.  
She played by the toy  
chest. That was fun.



Tim had a toy jet. He  
played by the steps.  
That was fun.

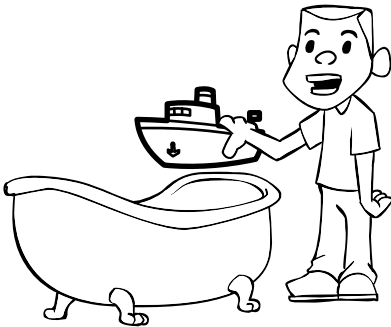

Jim had a ship. He  
played by the tub.  
That was fun.

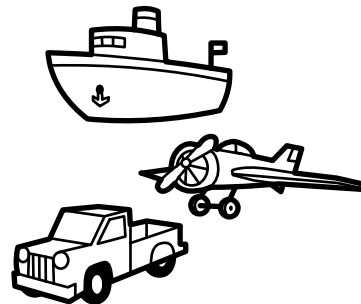

Kim and Tim and Jim  
all had fun. Now they  
can have fun together!

What is this story about?

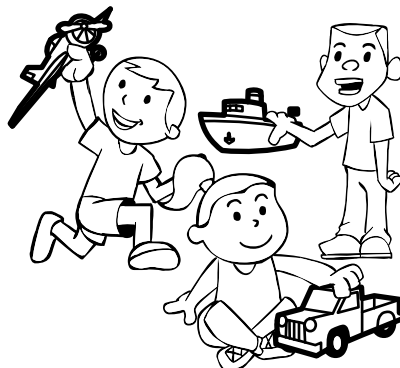

How are Kim, Tim, and Jim alike?

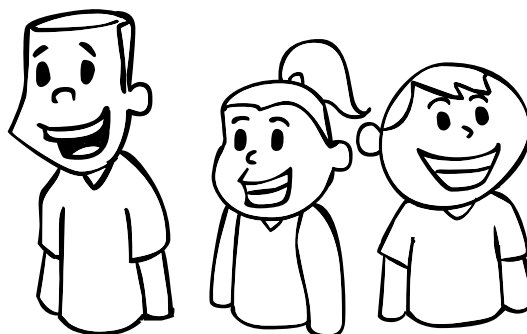

How are Kim, Tim, and Jim different?

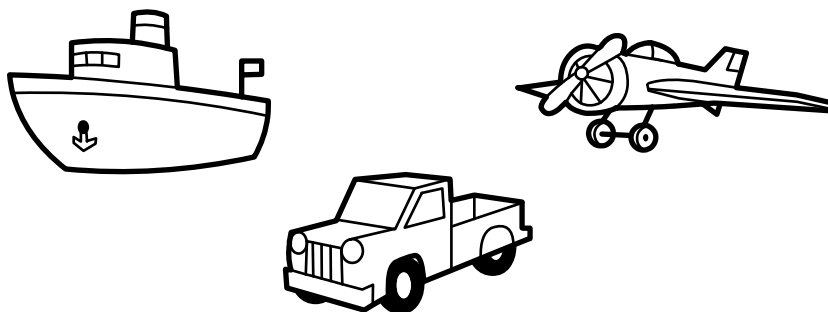

Draw the toy you like most.

**Answers will vary.**



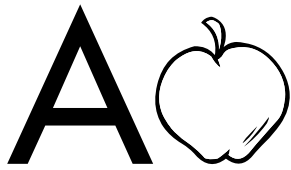

## Reading Words with Beginning Consonant Digraphs

**Directions:** Draw a line to match the pictures to the words.

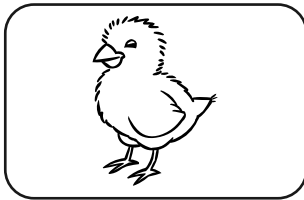
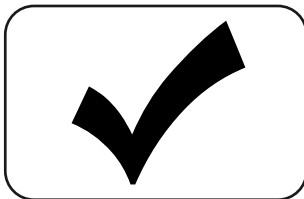
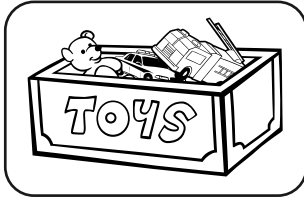

chick

check

chest

**Directions:** Cut out the letters. Then paste them in the boxes to make a word to match the picture.

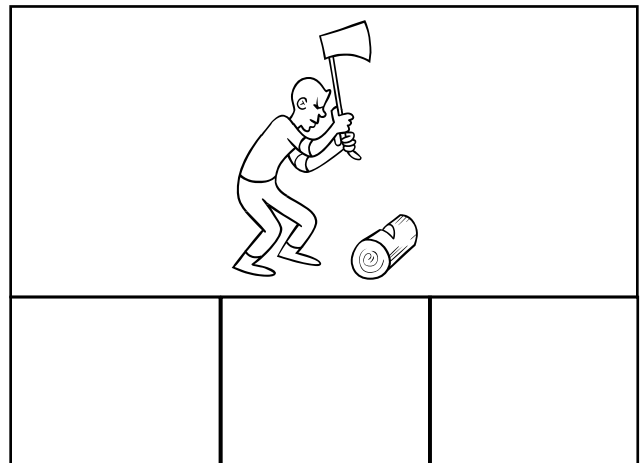
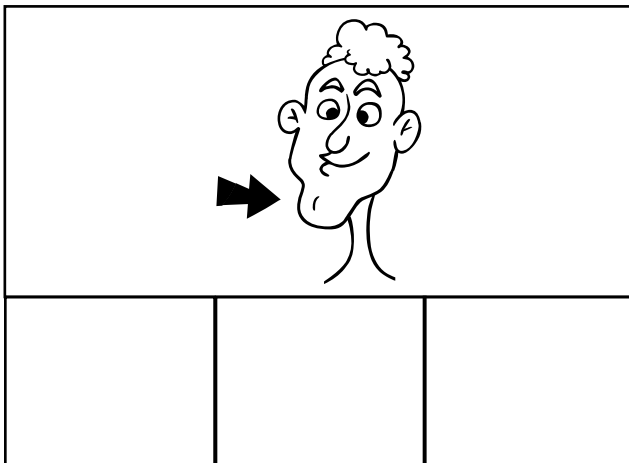

ch

p

i

ch

n

o

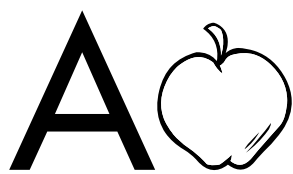

## Reading Words with Beginning Consonant Digraphs

**Directions:** Draw a line to match the pictures to the words.

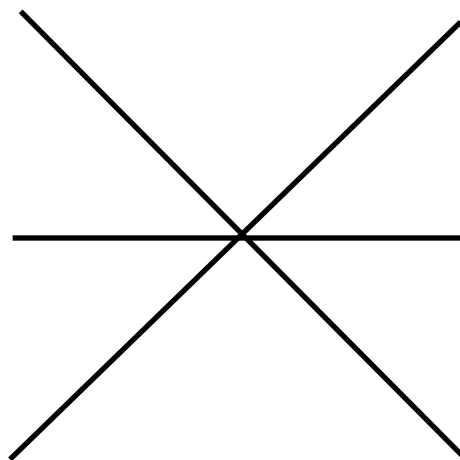
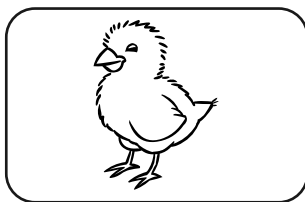
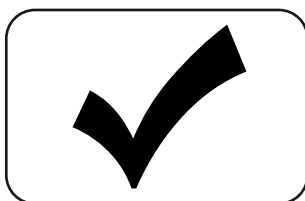
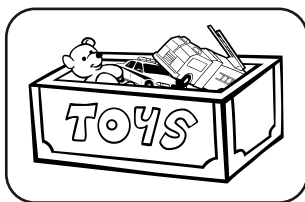

chick

check

chest

**Directions:** Cut out the letters. Then paste them in the boxes to make a word to match the picture.

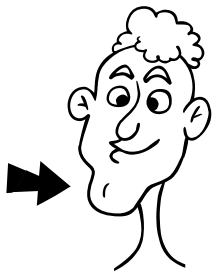

ch	i	n
----	---	---



ch	o	p
----	---	---

ch	p	i	ch	n	o
----	---	---	----	---	---



## Identifying the Correct Sequence of Events

**Directions:** Read the story. Then answer the questions.

Sam had a bug in a net.  
Pam had a bug in a jar.  
Sam's bug was red.  
Pam's bug was tan.  
Pam and Sam let the bugs go.

**Directions:** Color each bug from the story.

**Sam's bug**

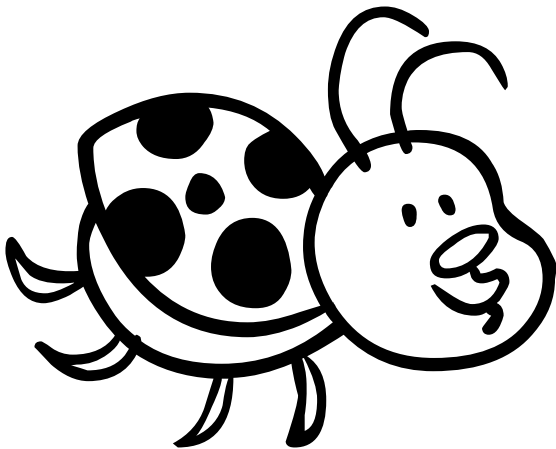

**Pam's bug**

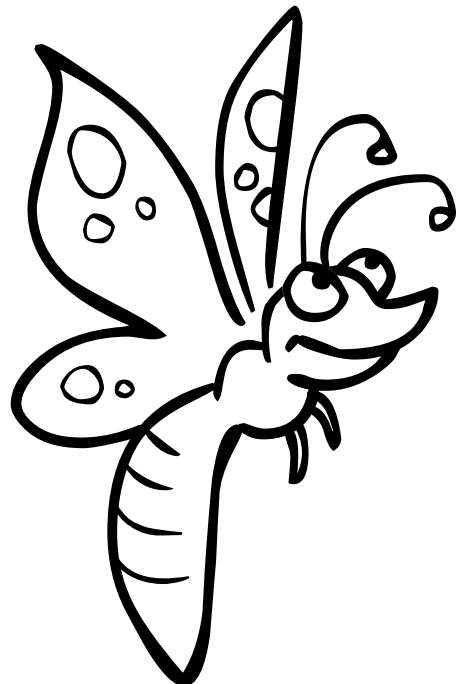

**Directions:** Draw the events of the story in order.

**First**

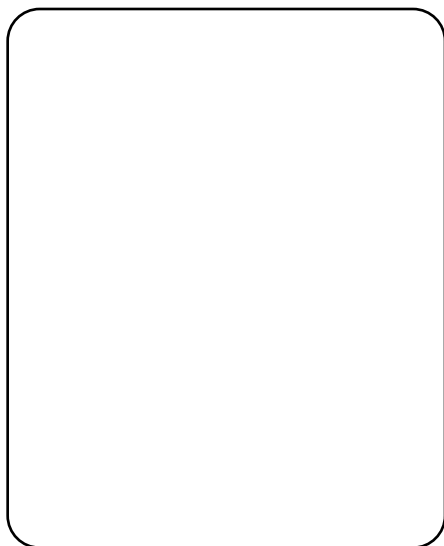

**Next**

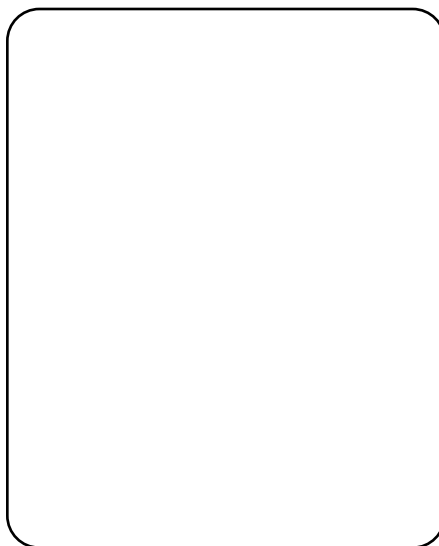

**Last**

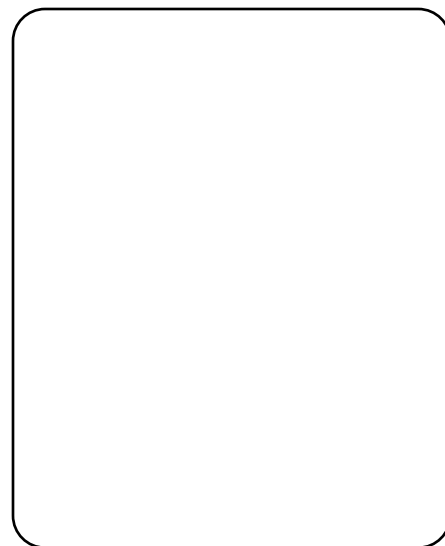

**Directions:** Did you ever catch a bug? Draw a picture of the bug.





## Identifying the Correct Sequence of Events

**Directions:** Read the story. Then answer the questions.

Sam had a bug in a net.  
Pam had a bug in a jar.  
Sam's bug was red.  
Pam's bug was tan.  
Pam and Sam let the bugs go.

**Directions:** Color each bug from the story.

**Sam's bug**

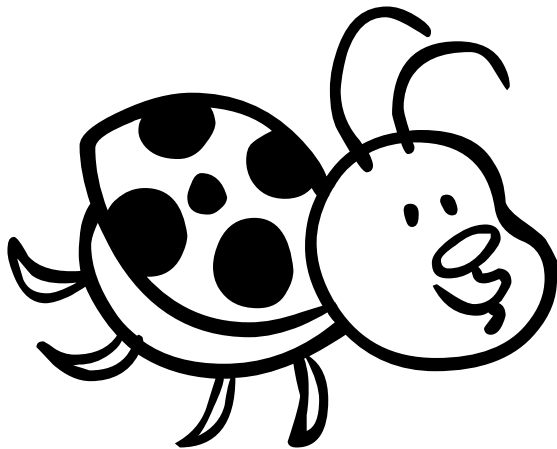

This bug should be colored red.

**Pam's bug**

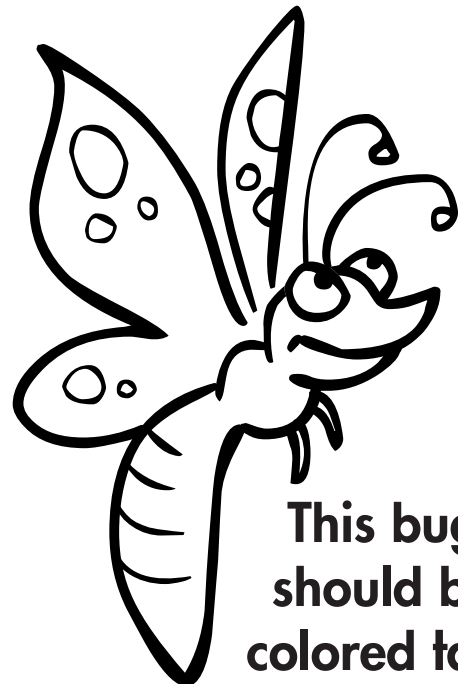

This bug should be colored tan.

**Directions:** Draw the events of the story in order.

**First**



**Next**

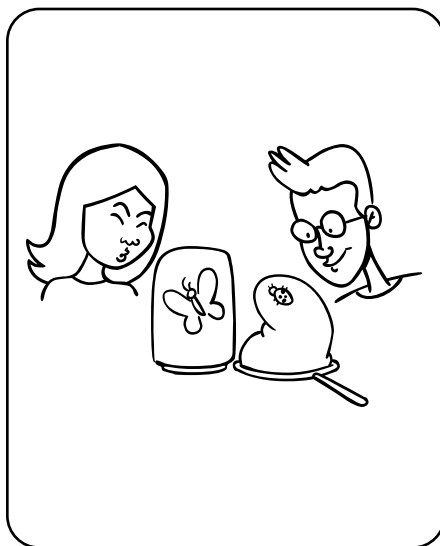

**Last**



**Directions:** Did you ever catch a bug? Draw a picture of the bug.

**Pictures will vary.**

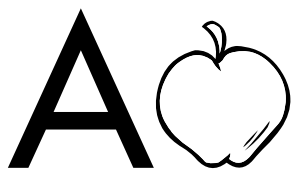

## Reading High Frequency Words

**Directions:** Draw pictures to match the words in each sentence.

Gus is on the bus with his dad.

Meg and Sid have one bag of nuts.

The hog sat in the mud by the log.

Kim had a sip from the cup.

They are on a jog in the fog.



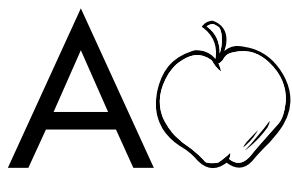

## Reading High Frequency Words

**Directions:** Draw pictures to match the words in each sentence.

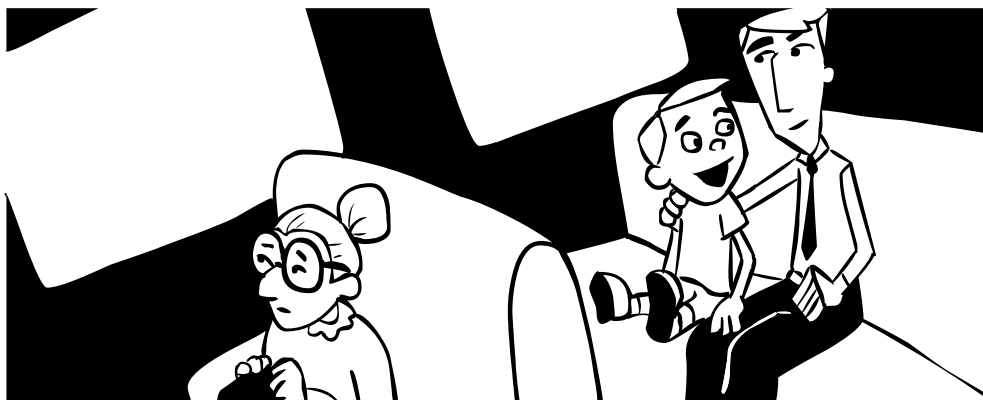

Gus is on the bus with his dad.

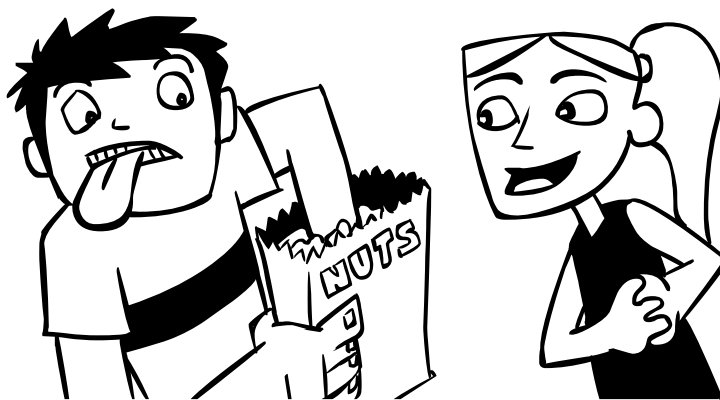

Meg and Sid have one bag of nuts.

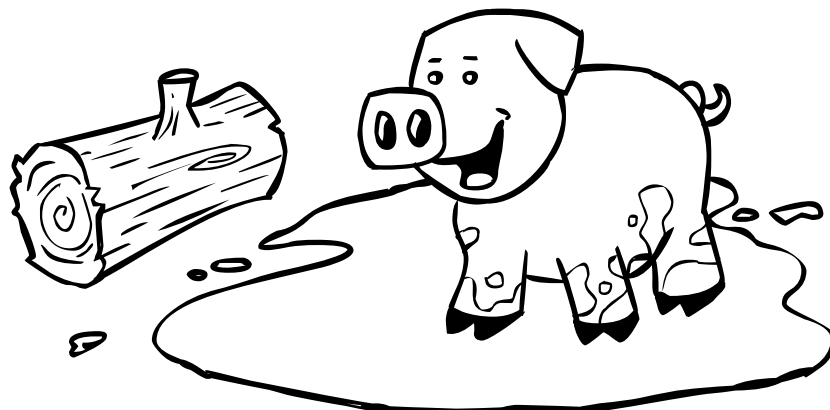

The hog sat in the mud by the log.



Kim had a sip from the cup.



They are on a jog in the fog.

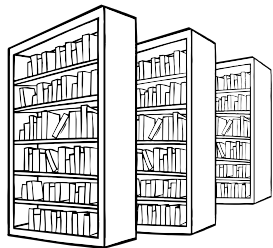

## Reading Fluently

**Directions:** Cut out the pages and put them in order. Staple the pages together. Read the story. Then draw pictures to match the words on each page.

### The Pig and the Dog

by Erin Lassiter

Name \_\_\_\_\_

A pig sat in the sun.

1

He met a dog.

2

He ran with the dog.

3

They had fun in the mud.

4

They got wet in a bog.

5

The pig had a nap  
in his pen.

6

The dog had a nap  
on his bed.

7

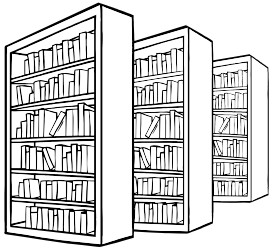

## Reading Fluently

**Directions:** Cut out the pages and put them in order. Staple the pages together. Read the story. Then draw pictures to match the words on each page.

### The Pig and the Dog

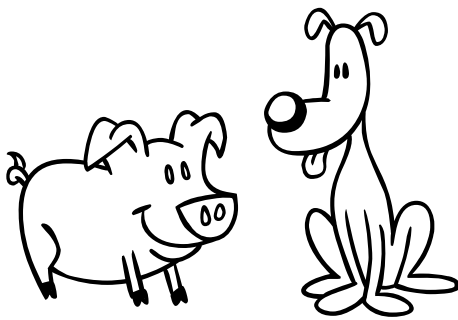

by Erin Lassiter

Name \_\_\_\_\_

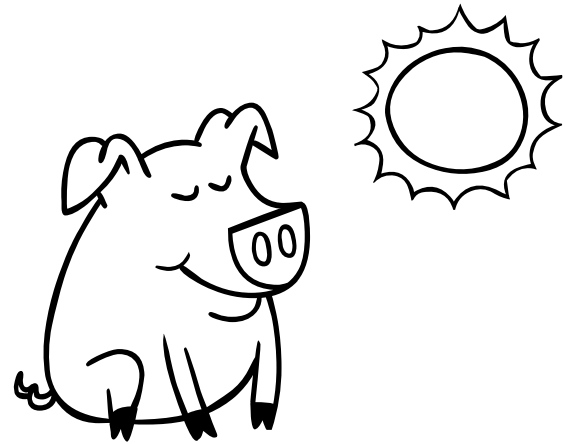

A pig sat in the sun.

1

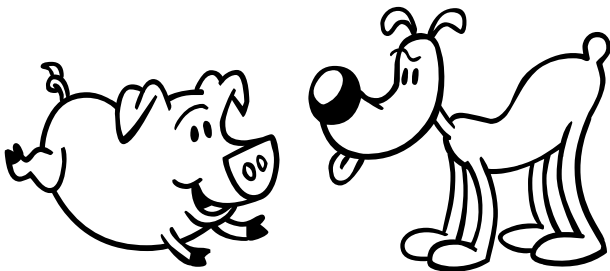

He met a dog.

2

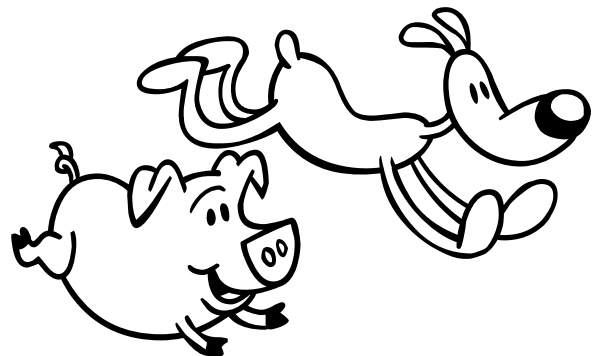

He ran with the dog.

3

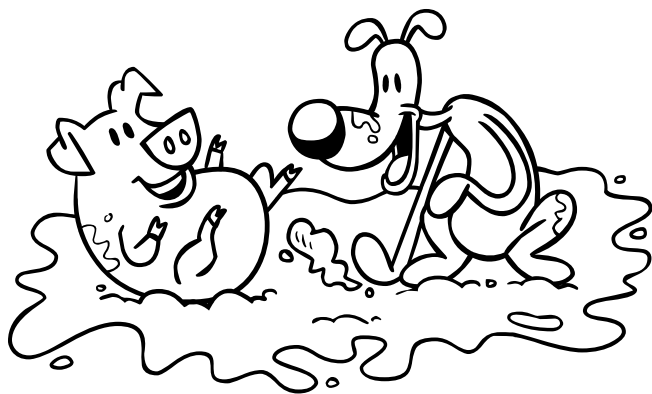

They had fun in the mud.

4

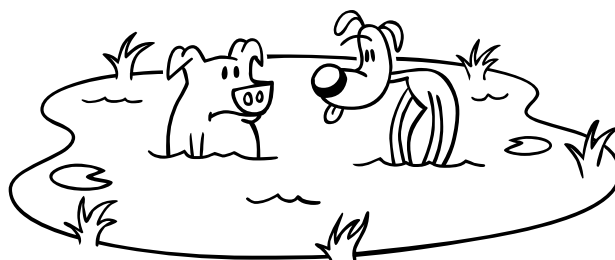

They got wet in a bog.

5

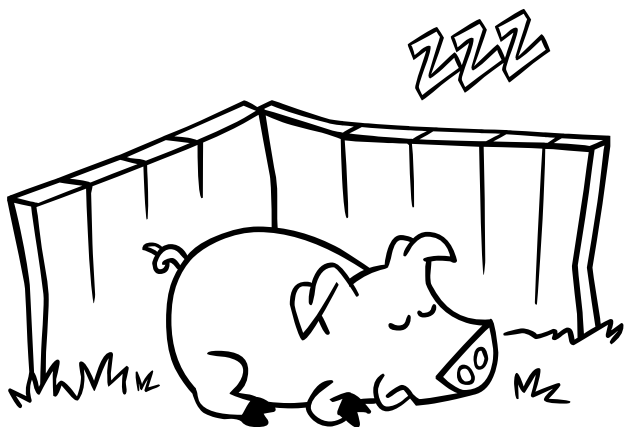

The pig had a nap  
in his pen.

6

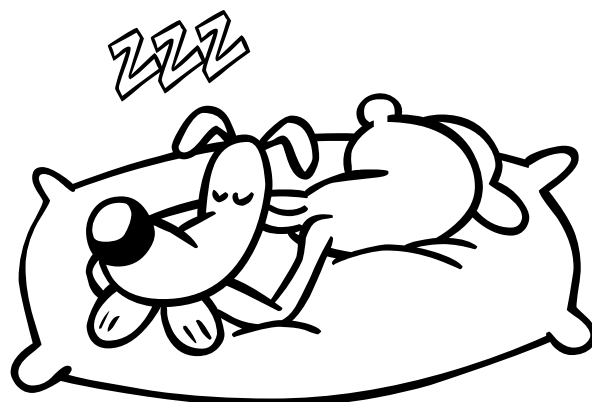

The dog had a nap  
on his bed.

7

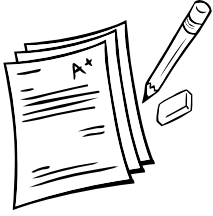

## Reading High Frequency Words and Sequencing Story Events

**Directions:** Read the story. Then answer the questions.

Jim got hit on the chin with a  .  
ball

He was  .  
sad

He sat in a  in the  .  
chair kitchen

His dad got him  for his chin.  
ice

His dad gave him have a hug.

Jim was  .  
happy

He ran to play with his  .  
ball

**Directions:** Draw pictures to answer the questions.

**Who?**

**What?**

**Where?**

**Why?**

**When?**

**Directions:** Draw the events of the story in order.

**First**

**Next**

**Then**



**Directions:** Who helps you when you get hurt? Draw a picture.

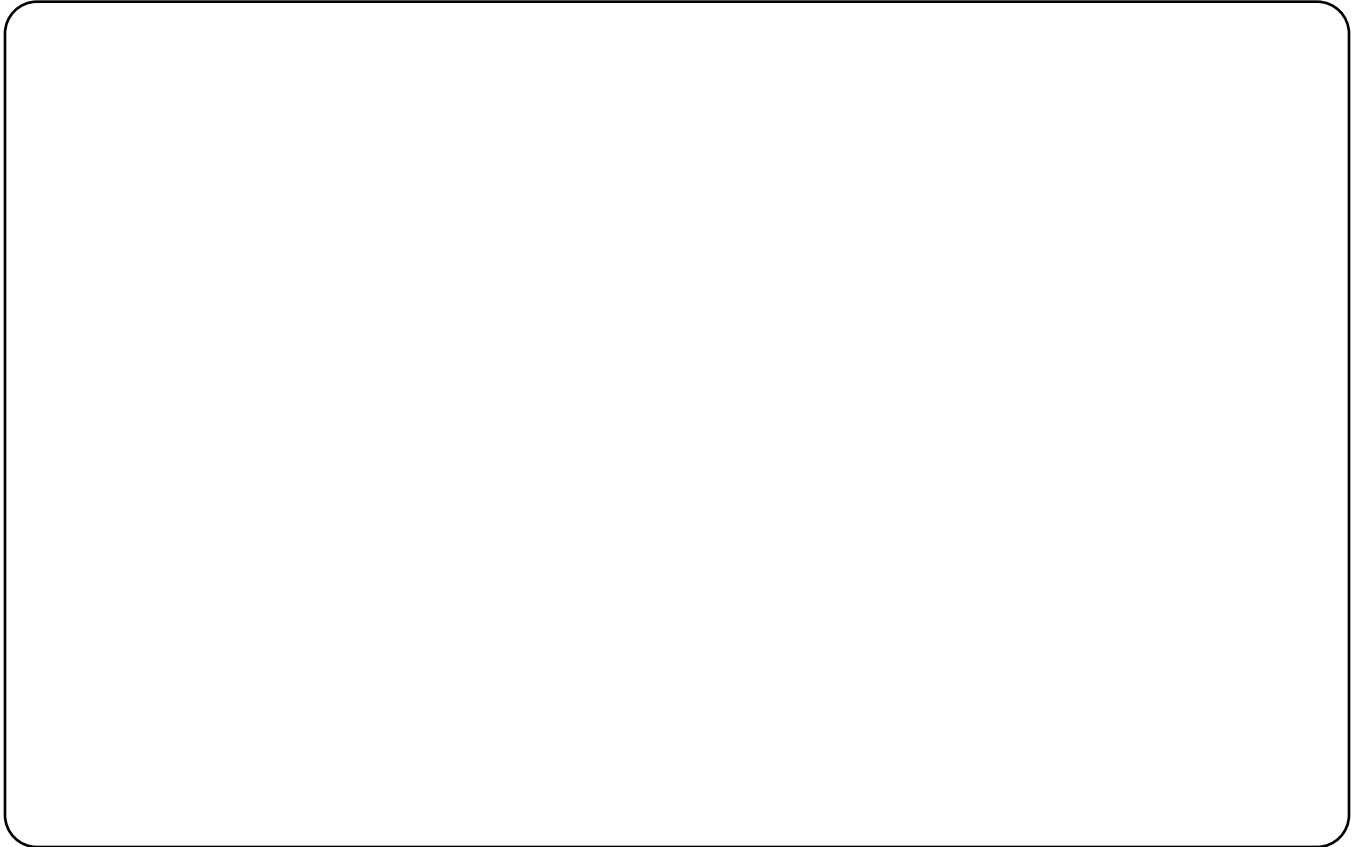



## Reading High Frequency Words and Sequencing Story Events

**Directions:** Read the story. Then answer the questions.

Jim got hit on the chin with a  .  
ball

He was  .  
sad

He sat in a  in the  .  
chair kitchen

His dad got him  for his chin.  
ice

His dad gave him have a hug.

Jim was  .  
happy

He ran to play with his  .  
ball

**Directions:** Draw pictures to answer the questions.

**Who?**

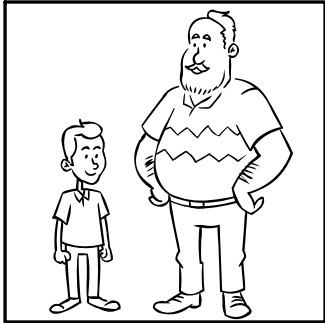

**What?**



**Where?**



**Why?**

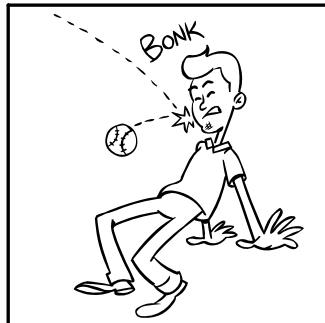

**When?**

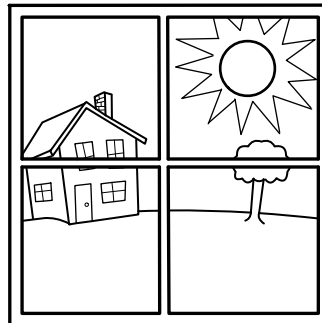

**Directions:** Draw the events of the story in order.

**First**

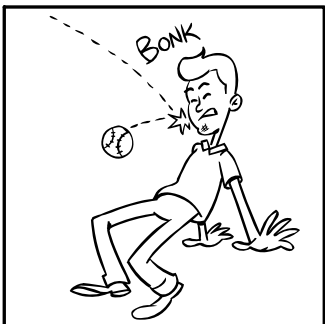

**Next**



**Then**



**Directions:** Who helps you when you get hurt? Draw a picture.

**Pictures will vary.**